



80-96 BRONCO/PICKUP
2013 Catalog



JBG

CHECK OUT OUR AWESOME
SELECTION OF PARTS AND
ACCESSORIES FOR YOUR LATE
MODEL BRONCO/PICKUP

EASY SECURE ONLINE ORDERING AT
WWW.BRONCOGRAVEYARD.COM
LOG ON FOR INTERNET ONLY SPECIALS,
FEATURES AND MORE!



CONTACT US TODAY!

PHONE:

248-437-5060

248-486-1760

FAX:

248-437-9354

WEB:

WWW.BRONCOGRAVEYARD.COM



The Bronco Graveyard is an industry leader in Ford Bronco restoration and aftermarket parts with more than 5000 quality products available. While the Bronco Graveyard brand is well known in the 1966-'96 Ford Bronco restoration marketplace, Bronco Graveyard also offers high quality parts for Ford truck 1973-'03, Bronco II, Ranger and Superduty.

Go to Broncograveyard.com to order your **FREE** catalogs today!



A leader in restoration parts the Bronco Graveyard offers the largest selection of 1966-'96 Bronco parts available.

1966-'77



1978-'79



1980-'96



Ford truck: the Bronco Graveyard offers bumper to bumper coverage. From body, drivetrain, weatherstripping, lift kits and more!

1973-'79



1980-'96



Bronco II, Ranger
1983-'97



The new workhorses of america. The Bronco Graveyard offers replacement and styling parts (online catalog only)

1997-'03



2004-'11



Superduty
1998-'10



Find The Bronco Graveyard on Facebook!



Share your off-road stories, and post pictures and videos of your adventures or your project vehicle. Our facebook page is also updated with new and upcoming products, as well as some Facebook exclusive specials. **Just search**

Broncograveyard.com on Facebook

Check out The Bronco Graveyard ON YOUTUBE!

The Bronco Graveyard Youtube channel is a great place to check out all of the Graveyard's NEW products and the truck of the month. Check it out!

www.youtube.com/TheBroncoGraveyard



Jeff's Bronco Graveyard Inc. has been serving the Bronco community for nearly 20 years. During that time we have steadily grown to become one of the largest sellers of Bronco parts and accessories in the country. We attribute this steady growth to our continued commitment to giving you the best possible price, quality and service. We guarantee the best prices in the industry, and to minimize down time, most orders are shipped the day they are placed. Our recent expansion boasts a 26,000 sq. ft. warehouse to help us expedite your order. We thank you for all your continued support and look forward to serving your future Bronco needs.

Hours of operation

Mon. - Wed: 9:00 a.m.- 6:00 p.m.(EST)

Thurs. - Friday: 9:00 a.m.- 5:00 p.m.(EST)

Our store never closes at www.broncograveyard.com

Ordering

Orders are accepted by phone, fax, mail, or on the web at our secure website: www.broncograveyard.com

Phone: (248) 437-5060
(248) 486-1760

Fax: (248) 437-9354

Address: **Jeff's Bronco Graveyard**
7843 Lochlin Dr.
Brighton, MI 48116

Method of payment

JBG accepts Visa, Mastercard, American Express, Discover and Debit cards. No COD's.

Shipping methods

All orders will be shipped via UPS ground service or USPS at our discretion, unless otherwise noted. Special shipping services may be available at additional cost (Next day air, 2 day air, Saturday delivery etc.)

All FPO, APO and International orders will be shipped via USPS.

Pricing policy

JBG does not assume responsibility for errors or omissions found in this catalog. Prices are subject to change without notice. For current prices call us, or visit:

www.broncograveyard.com



Returns

All returns to **Jeff's Bronco Graveyard Inc.** must be accompanied by an RMA number. Please see following page for a complete description of our return policy

Core returns

All cores must be returned within 90 days for core credit, and be accompanied by a copy of original receipt.

Damaged shipments

In the event of receiving a damaged shipment, please notify us, and the shipper (UPS, USPS etc.) immediately for further instructions.

Warranty terms

New Part: 90 days

Rebuilt: 90 days

Used: 30 Days

All warranty submissions will be subject to inspection by **Jeff's Bronco Graveyard Inc.** Warranty approval will be granted on a case by case basis.

Truck shipments

Products that are either too large or too heavy for our conventional ground carrier (UPS, USPS, etc.), will be shipped via truck freight. All truck freight orders are shipped freight collect (you pay the driver for shipping costs). Residential deliveries are subject to an additional fee.

CONTENTS

Automatic Transmission	Pg. 34
Big Block Conversions.....	Pg. 30
Body Sheet Metal	Pg.129
Brakes	Pg.92
Bumpers	Pg. 151
Carpet.....	Pg. 171
Clutch	Pg. 40
Consoles & Secure Storage	Pg. 181
Dashboard	Pg. 167
Diesel Parts	Pg. 175
Door Panels.....	Pg. 140
Door Parts	Pg. 135
Driveshafts.....	Pg. 89
Electrical	Pg. 184
Emblems.....	Pg. 157
Engine Cooling & Heat	Pg. 14
Engine Parts	Pg. 24
Exhaust.....	Pg. 1
Fender Flares	Pg. 160
Flex-A-Lite fans	Pg. 22
Front End (Dana 44 IFS).....	Pg. 49
Front End (Dana 44 Monobeam).....	Pg. 78
Front End (Dana 50 IFS).....	Pg. 56
Front End (Dana 60 Monobeam).....	Pg. 59
Fuel Tanks	Pg. 6
Grill	Pg. 148
Half Cab Conversion	Pg. 162
Hood Parts.....	Pg. 182
Locking Fasteners	Pg. 88
Lighting.....	Pg. 150
Manual Transmission.....	Pg. 36
Oil Pans.....	Pg. 4
Polyurethane	Pg. 104
Rear End (8.8").....	Pg. 69
Rear End (9").....	Pg. 64
Rear End (10¼").....	Pg. 72
Rear End (Dana 60)	Pg. 75
Rear End (Dana 80)	Pg. 77
Roll Bars.....	Pg. 183
Seals & Weatherstrip.....	Pg. 163
Starters & Alternators	Pg. 33
Seats (Corbeau).....	Pg. 176
Shocks.....	Pg. 127
Soft Tops.....	Pg. 161
Speedo Gear	Pg. 63
Steering Components.....	Pg. 101
Steering Column.....	Pg. 159
Straight Axle Conversion	Pg. 126
Suspension.....	Pg. 111
T-Shirts & Decals.....	Pg. 186
Tailgate	Pg. 144
Tools & Repair	Pg. 29
Torque Specs.....	Pg. 187
Transfer Case	Pg. 43
Winches.....	Pg.155
Wipers	Pg.156

EXHAUST

300 6 CYL. MANIFOLDS*

30030	1980-83, Bronco/Pick-up	\$205
30032	1984-86, W/Heat Riser	\$135
30036	1987-94, Front Section	79
30037	1987-94, Rear Section	\$79

*includes manifold studs

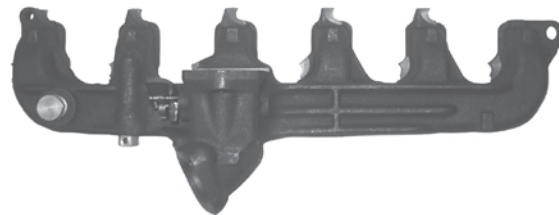

302 MANIFOLDS*

30004	1980-85, RH, W/O ₂ Sensor Hole	\$82
30005	1987-96, RH, W/O ₂ Sensor Hole	\$72
30006	1980-96, LH, W/O Exhaust Valve	\$84
30007	1983-87, LH, W/Exhaust Valve	\$95
30018	Exhaust Manifold Hardware, 302, 351W	\$8

*includes manifold studs & gaskets.

351W MANIFOLDS*

30008	1980-87, RH, W/O ₂ Sensor Hole	\$84
30010	1988-96, RH, W/O ₂ Sensor Hole	\$84
30012	1980-83, LH, W/O Exhaust Control	\$84
30014	1983-87, LH, W/Heat Riser	\$99
30016	1988-96, LH, W/Air Holes	\$99
30019	88-97, Exhaust Manifold Hardware Kit	\$8

*includes manifold studs & gaskets.



**351M/400 MANIFOLDS***

30000	1980-82, RH, Exhaust Manifold	\$95
30002	1980-82, LH, Exhaust Manifold	\$129

*includes exhaust flange studs

460 MANIFOLDS*

30040	1980-88, LH	\$100
30041	1989-96, LH	\$100
30043	1980-88, RH	\$125
30044	1989-96, RH	\$125
30044H	87-96 460 Manifold Hardware	\$10

*includes exhaust flange studs & gaskets

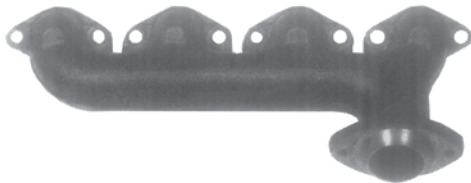
**7.3L DIESEL**

30075	7.3L Diesel Exhaust Manifold, LH	\$125
30076	7.3L Diesel Exhaust Manifold, RH	\$125

EXHAUST EMISSIONS

30082	EGR tube, 90-97 5.8L	\$25
30084	EGR tube, 90-97 7.5L	\$25
30086	EGR tube, 94-97 7.3L Diesel	\$23
30090	"Y" Pipe, W/Cat Converter, 4.9L	\$238
30092	"Y" Pipe, W/Cat Converter, 5.0L	\$215
30094	"Y" Pipe, W/Cat Converter, 5.8L	\$229



HEDMAN HEDDERS®

Hedman Hedders has earned its reputation as a quality header manufacturer by being in the winner circle with World Champions like “Big Daddy” Don Garlits, Warren Johnson, Scott and Connie Kalitta, Richard Petty, and Frankie Kerr. Hedman Hedders were selected by the IROC Series as their header an amazing 21 consecutive years, and they are the only header ever to run on Bob Chandlers “BigFoot” Monster Trucks. These Hedman Hedders feature 1½” primary tubes and 3” collector tubes.



30045	80-96 Bronco/PU 302	\$209	30048	83-87, F150-350, 460	\$209
30046	81-96 Bronco/PU 351W	\$209	30049	88-95, F150-350, 460	\$239
30047	80-85 Bronco/PU 351M	\$235			



HEADER GASKETS

Made from materials that withstand temperatures up to 3000° these Remflex header gaskets won't burn out like others. These extra thick gaskets even help fill irregularities in flange surfaces. No need to re-torque.

10070	Header Gskts, 69-80, 289/302	\$28	10078	Header Gskts, 429/460 Oval	\$33
10071	Header Gskts, 65-86, 300 6 Cyl.	\$38	10079	Header Gskts, 460 Cobra Jet	\$38
10072	Header Gskts, 81-96, 302	\$28	10080	Header Gskts, 460 Square Port	\$33
10074	Header Gskts, 69-97, 351W	\$28	10084	Header Gskts, "FE" Engines	\$58
10076	Header Gskts, 75-82, 351M/400	\$33	10085	Collector Gaskets, 3", 3 Bolt	\$14

STAGE 8 LOCKING HEADER BOLTS

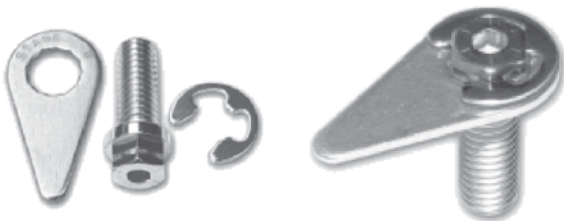

Stage 8 Locking header bolts. Easy to use and they are absolute insurance against horsepower loss or gasket failure created by loose nuts or bolts. The unique patented and trademarked functional design is just three pieces: a bolt (4130 Alloy Steel), a locking retainer and a spring clip.

10050	Stage 8 Locking Header Bolts	\$53
-------	------------------------------	------

More Stage 8 products on page 85.

OIL PAN

OIL PANS

Black powder coat finish inside & out.



300 6 Cyl. oil pan

30100	300 6Cyl., 80-82 Bronco/Pick-up	\$110
30101	300 6Cyl., 83-92 Bronco/Pick-up	\$70
30120	302 V-8, 80-96 Bronco/Pick-up	\$73
30140	351W V-8, 80-86 Bronco/Pick-up	\$95
30141	351W V-8, 87-96 Bronco/Pick-up	\$75
30182	460 V-8, 80-89 Bronco/Pick-up	\$90
30183	460 V-8, 89-93 Bronco/Pick-up	\$95
30184	460 V-8, 93-96 Bronco/Pick-up	\$90
30194	83-94, 6.9/7.3 Diesel	\$120
30195	95-97, 7.3L Diesel	\$120

DIPSTICKS

30102	Dipstick, 1980-96 300 6 Cyl.	\$18
30121	Dipstick, 1980-84 302 V-8	\$20
30122	Dipstick, 1985-96 302 V-8	\$17
30142	Dipstick, 1980-96 351W V-8	\$19
30162	Dipstick, 1980-82 351M V-8	\$15
30185	Dipstick, 1980-96 429/460	\$35

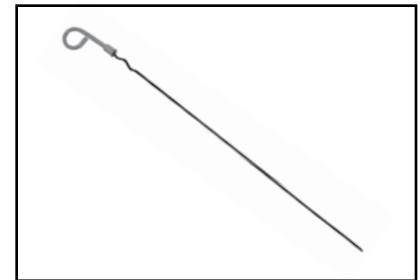

DIPSTICK TUBES

30104	Dipstick Tube, 300 6 Cyl., 82-86	\$76
30105	Dipstick Tube, 300 6 Cyl., 87-96	\$59
30124	Dipstick Tube, 302 V-8, 85-88	\$35
30125	Dipstick Tube, 302 V-8, 89-91	\$35
30127	Dipstick Tube, 302 V-8, 92-96	\$35
30117	Dipstick Tube, 302/351W Stainless, Flex	\$45
30144	Dipstick Tube, 351W, 80-86	\$40
30145	Dipstick Tube, 351W, 92-96	\$35
30164	Dipstick Tube, 351M, 80-82	\$31
30187	Dipstick Tube, 460, 80-96 (push in)	\$40
30188	Dipstick Tube, 460, 80-96 (snap in in)	\$90
30189	Dipstick Tube, 460, 91-96 (push in)	\$80



PICKUP TUBE & STUD

30126	Pickup Tube, 302 V-8, 80-96	\$38
30146	Pickup Tube, 351W V-8, 87-96	\$38
30191	Pickup Tube, 460, 80-96	\$46
30129	Pickup Stud, 302 V-8, 80-96	\$14
30192	Pickup Stud, 460, 80-96	\$15

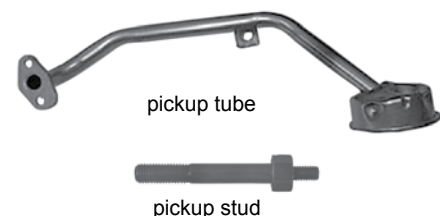

MILODON OIL PANS

For over 45 years, the Milodon name has been synonymous with premium quality racing components. Milodon's roots extend into virtually all forms of automotive and marine competition. Milodon has taken its advanced technology to the street, manufacturing a wide range of race quality products to enhance street performance and reliability.



20150	Milodon Oil Pan, 351W	\$319	20140	Milodon Oil Pan, 429/460	\$319
20152	Milodon Pickup Tube, 351W	\$75	20142	Milodon Pickup Tube 429/460	\$75
20115	Milodon Oil Pan, 351M/400	\$370			
20116	Milodon Pickup Tube, 351M/400	\$75			

ONE PIECE OIL PAN GASKET

Milodon one piece pan gasket ends leaks at the corners where conventional individual gaskets meet. These molded rubber gaskets are reusable too. They have steel inserts around each bolt hole so the pan bolts can be securely tightened yet the gasket can never be over tightened.

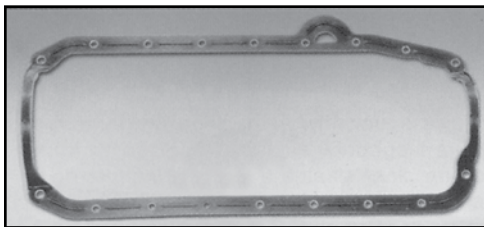

10160	One Piece Oil Pan Gasket, 302	\$39
10162	One Piece Oil Pan Gasket, 351W	\$39
10164	One Piece Oil Pan Gasket, 429/460	\$39

CRUSH PROOF GASKETS

10161	Crush Proof Oil Pan Gasket, 302	\$16
10163	Crush Proof Oil Pan Gasket, 351W	\$16
10165	Crush Proof Oil Pan Gasket, 351M/400	\$16
10167	Crush Proof Oil Pan Gasket, 429/460	\$16

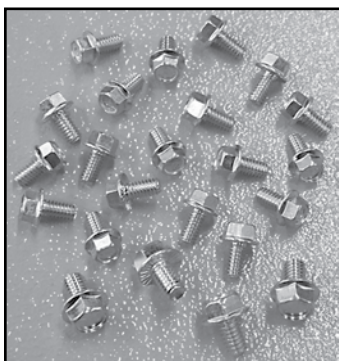
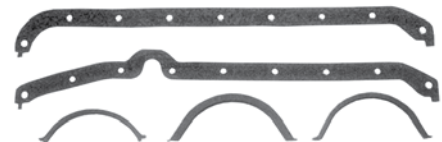

OIL PAN ACCESSORIES

10144	Oil Pan Bolt Kit	\$10
30117	Stainless Steel Flex Dipstick Tube, 302/351W	\$45

BRONCO FUEL TANKS

PLASTIC FUEL TANKS

Is your existing tank rusting and/or leaking? Not a problem. Replace it with one of these Polyethylene units. Nearly ¼" thick, these tanks will never rust. Won't crack even at 150° below zero. No welds or seams to fail or leak. Shipped with new O-ring seal and lock ring.

30202	25½ Gallon Tank, 1980-83 Bronco	\$145
30202	25½ Gal. Tank, 80-83 Bronco	\$145
30212	33 Gal. Tank W/2" Sender, 80-89 Bronco	\$145
30216	33 Gal. Tank W/3⅝" Sender, 90-96 Bronco	\$145



STEEL FUEL TANKS

For those of you looking for something more like the stock fuel tank, these steel replacement units will do the trick.

30200	25½ Gallon, 1980-83 Bronco	\$129
30214	33 Gallon W/ 2" Sender Hole, 1980-89 Bronco	\$110
30217	33 Gal. W/3 5/8" Sender Hole, 1990-96 Bronco	\$110

FUEL FILL HOSE

30218	Rear Tank Fill Hose, 80-96 Bronco	\$25
30262	5/16" Fuel Line Connector Repair, Straight	\$15
30263	5/16" Fuel Line Connector Repair, 90°	\$15



SKID PLATE

- | | | |
|-------|---|------|
| 30270 | 33 Gallon Skid Plate, 1980-96 Bronco | Soon |
| 30272 | Upper Tank Strap, 1980-96 Bronco (each) | \$15 |



LOWER TANK STRAPS

- | | | |
|-------|---------------------------------|------|
| 30276 | 1980-83 Bronco, 25 Gallon, Pair | \$45 |
| 30278 | 1980-96 Bronco, 33 Gallon, Pair | \$45 |

SENDING UNIT (NON EFI ENGINE)

- | | | |
|--------|--|------|
| 30249 | 1980-83 Bronco, 25½ Gal. Sending Unit Aft* | \$60 |
| 30250A | 1980-84 Bronco, 33 Gal. Sending Unit Aft* | \$60 |
| 30251A | 1985-86 Bronco, 33 Gal. Sending Unit Aft* | \$60 |

*stainless steel construction

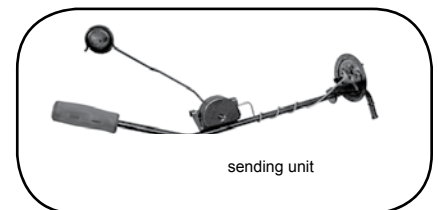

SENDING UNIT (EFI ENGINE) 1985-89

- | | | |
|--------|-----------------------------------|------|
| 30252A | 1985-86, Bronco Sender W/33 Gal. | \$50 |
| 30253P | 85-89 Internal Fuel Pump kit | \$69 |
| 30254 | 1987-89, Bronco, Sender W/33 Gal. | \$60 |
| 30254A | 87-89 Sender, 33 Gal | \$50 |
| 30254P | 85-89 External Fuel Pump Kit | \$99 |
| 30254S | 85-89 Fuel Pump Strainer | \$8 |



SENDING UNIT (EFI ENGINE)

30252A	1985-86, Bronco Sender W/33 Gal.	\$50
30254	1987-89, Bronco, Sender W/33 Gal.	\$60
30255	1990-96, Bronco, OEM Sender & Pump W/33 Gal.	\$469
30256	1990-96, Bronco, Sending Unit Only, OEM	\$125
30256A	1990-96 Bronco, Sending Unit Only, Aftermarket	\$56
30256P	1990-96, In Tank Fuel Pump Kit	\$169
30257	1990-96, Fuel Pump Only, OEM	\$349

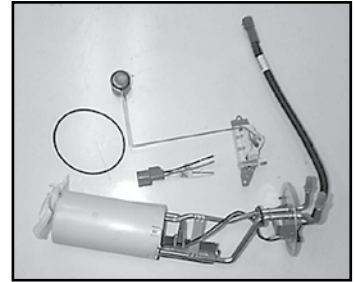
**SENDING UNIT PLUGS**

20232	Sending Unit Pigtail, 80-86, Non EFI	\$12
30258	Sending Unit Pigtail, 90-96	\$13
30295	Gas Cap, 80-86 Bronco	\$7
30296	Gas Cap, 87-96 Bronco	\$10

MECHANICAL FUEL PUMPS

30232	Fuel Pump, 80-86, 300 Six Cyl.	\$29
30232A	Fuel Pump, 80-86, 300 Six Cyl. (canadian vehicle)	\$36
30234	Fuel Pump, 80-85, 302	\$26
30235	Fuel Pump, 80-87, 351W	\$26
30235A	Fuel Pump, 85-87, 3561W (canadian vehicle)	\$26
30236	Fuel Pump, 80-82, 351M	\$29
30238	Fuel Pump, 83-85, 460	\$29
30238A	Fuel Pimp, 86, 460	\$29

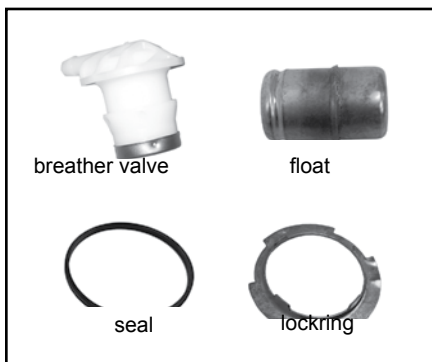
**HARDWARE**

30340	Sending Unit Lock Ring, 2" Dia.	\$6
30341	Sending Unit O-Ring Seal, 2" Dia.	\$1
30342	Sending Unit Lock Ring, 3-5/8" Dia.	\$6
30343	Sending Unit O-Ring Seal, 3-5/8" Dia.	\$2
30259	1980-87 Breather Valve	\$39
30259S	1980-87 Breather Valve Seal	\$6
30260	1988-96 Breather Valve	\$45
30290	Sending Unit Filter	\$7
30292	Sending Unit Float	\$5

TRUCK FUEL TANKS



PLASTIC REAR TRUCK TANKS

Made from the same tough, durable polyethylene as our Bronco tanks (previous page) so they share all the same features. Bolt one in and say goodbye to rust forever. 19 gallon capacity. Shipped with new lock-ring and sender seal.

30322	80-86, Rear Tank W/2" Sender Hole	\$139
30326	85-89, Rear Tank W/3 ⁵ / ₈ " Sender Hole	\$139
30330	90-96, Rear Tank W/3 ⁵ / ₈ " Sender Hole	\$139

STEEL REAR TRUCK TANK

30324	80-84 W/2" Sender Hole	\$109
30327	85-86 W/3 ⁵ / ₈ " Sender Hole	\$109
30328	87-89 W/3 ⁵ / ₈ " Sender Hole	\$109
30329	90-96 W/3 ⁵ / ₈ " Sender Hole	\$109

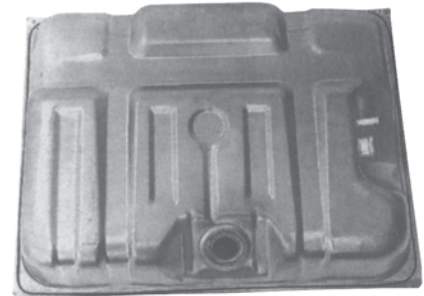

REAR TANK SENDER (GASOLINE)

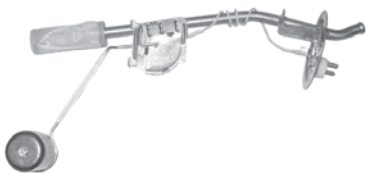

30379	80-84, 19 Gal. Rear Sending Unit, AFT	\$50
30380	80-84, 19 Gal. Rear Sending Unit, OEM	\$149
30381	85-86, 19 Gal. Rear Sending Unit, AFT	\$59
20232	Sending Unit Pigtail	\$12

REAR TANK SENDER W/EFI (GASOLINE)

30383	85-89, 19 Gal. Rear Sending Unit, W/EFI	\$59
30383P	85-89, In Tank Fuel Pump	\$42
30384	90-91, 19 Gal. Rear Sending Unit, W/EFI	\$70
30384P	90-91, In Tank Fuel Pump	\$57
30385	92-96, 18 Gal. OEM Rear Sending Unit, W/EFI	\$60
30385P	92-96, In Tank Fuel Pump	\$42
30258	Sending Unit Repair Plug	\$13

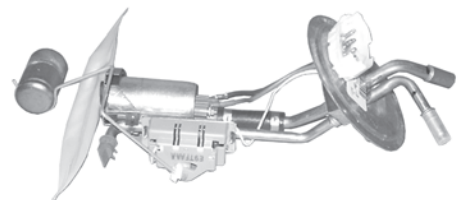

AIRTEX FUEL PUMP/SENDER

30352	80-82 Fuel Pump/Sender, 19 Gal Rear	\$149
30352P	80-82 In Tank Fuel Pump Kit	\$69
30352S	80-82 Fuel Pump Strainer	\$8
30353	83-84 460, Fuel Pump/Sender, W/19 Gal Rear	\$149
30353P	83-84 460, Fuel Pump Kit	\$69
30353S	83-84 Fuel Pump Strainer	\$8
30354	85-86 302, Fuel Pump/Sender W/19 Gal Rear Tank	\$145
30354C	85-86 F250, 302, Pump/Sender, W/17 & 19 Gal. Center Tank	\$99
30354PA	85-89 In Tank Fuel Pump Kit	\$42
30354S	85-89 Fuel Pump Strainer	\$8
30355	85-86 460, Pump/Sender W/19 Gal Plastic Rear Tank	\$109
30355P	85-86 460, In Tank Fuel Pump Kit	\$69
30355S	85-86 Fuel Pump Strainer	\$8
30359	87-89 Pump/Sender W/19 Gal Steel Rear Tank	\$125
30359EP	85-89 External Fuel Pump Kit	\$99
30359M	85-89 In Tank Fuel Pump Kit W/Steel Rear Tank	\$59
30359P	88-89 In Tank Fuel Pump Kit W/Plastic Rear Tank	\$69
30359S	85-89 In Tank Fuel Pump Kit W/17 or 19 Gal Side Tank	\$59
30360	90-97 In Tank Fuel Pump Kit W/Steel 19 Gal Rear Tank	\$145

**SENDING UNIT HARDWARE**

30340	Sender Lock-ring (2" sender)	\$5
30341	Sender Seal (2" sender)	\$1
30342	Sender Lock-ring (3 $\frac{5}{8}$ " sender)	\$5
30343	Sender Seal (3 $\frac{5}{8}$ " Sender)	\$2
30290	Sending Unit Filter	\$7
30292	Sending Unit Float	\$5

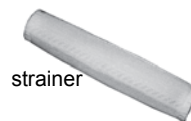
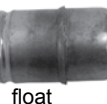

float

strainer

REAR TANK FILLER HOSE

30320	80-96, Rear Tank Filler Hose, Styleside	\$20
30321	80-96, Rear Tank Filler Hose, Stepside	\$13
30320N	90-97, Rear Tank Filler Neck	\$80

REAR TANK MOUNTING STRAPS

- | | | |
|-------|-------------------------------------|------|
| 30374 | 80-96, Lower Mounting Straps (pair) | \$30 |
| 30375 | 80-96, Upper Mounting Straps (pair) | \$19 |

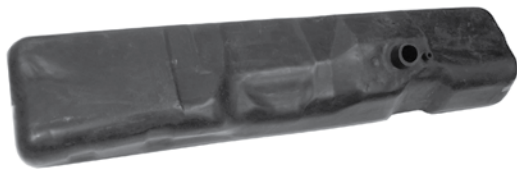
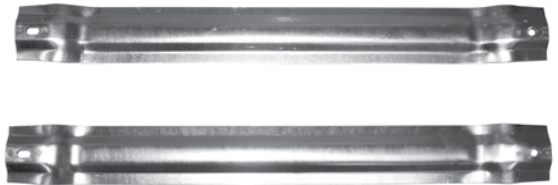

PLASTIC SIDE TANKS (8' BED)

- | | | |
|-------|-------------------------------------|-------|
| 30333 | 80-84, 19 Gal. W/2" Sender Hole | \$145 |
| 30336 | 85-96, 19 Gal. W/3-5/8" Sender Hole | \$145 |

STEEL SIDE TANKS (8' BED)

- | | | |
|-------|-------------------------------------|-------|
| 30332 | 80-84, 19 Gal. W/2" Sender Hole | \$109 |
| 30334 | 85-86, 19 Gal. W/3-5/8" Sender Hole | \$119 |
| 30335 | 87-89, 19 Gal. W/3-5/8" Sender Hole | \$109 |
| 30337 | 90-95, 19 Gal. W/3-5/8" Sender Hole | \$119 |

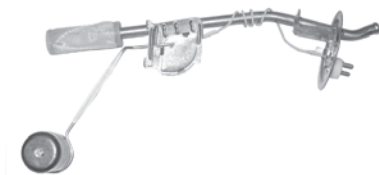

19 GAL. SIDE TANK SENDING UNIT (GASOLINE)

- | | | |
|-------|------------------------------------|------|
| 30387 | 80-84, Side Tank Sending Unit, AFT | \$60 |
| 20232 | Sending Unit Repair Pigtail | \$12 |

19 GAL. SIDE TANK SENDER W/EFI (GASOLINE)

- | | | |
|--------|---|------|
| 30389 | 85-86, 19 Gal. Side Tank Sending Unit W/EFI | \$79 |
| 30389P | 85-86, In Tank Fuel Pump | \$42 |
| 30390 | 87-89, 19 Gal. Side Tank Sending Unit W/EFI | \$79 |
| 30391 | 90-91, 19 Gal. Side Tank Sending Unit W/EFI | \$80 |
| 30391P | 90-91, In Tank Fuel Pump | \$56 |
| 30392 | 92-96, 19 Gal. Side Tank Sending Unit W/EFI | \$80 |





AIRTEX SIDE TANK FUEL PUMP/SENDER

30352A	80-82 Fuel Pump/Sender W/19 Gal Center Tank	\$135
30353A	83-94 460, Fuel Pump/Sender W/19 Gal Center Tank	\$135
30354A	85-86 302, Fuel Pump/Sender, W/17 Gal Center Tank	\$109
30354C	85-86 F250 302, Pump/Sender, W/ 17 or 19 Gal Center Tank	\$99
30355A	85-86 460, Fuel Pump/Sender, W/Steel Center Tank	\$109
30359C	87-89 Fuel Pump/Sender, W/17 Gal Side Tank	\$115
30361	90-97 In Tank Fuel Pump Kit	\$169

SIDE TANK MOUNTING STRAPS

30376	80-96, 19 Gal Side Mount Straps (pair)	\$35
-------	--	------



TANK SWITCHING

30302	92-97, Tank Selector Dash Switch	\$12
10261	80-85, Electric Tank Switching Valve	\$39
30362	86-90, Electric Tank Switching Valve	\$75

FILLER NECK/HOSE

30331	Side Tank Filler Hose	\$25
30262	Fuel Line Connector Repair Kit, Staright	\$15
30263	Fuel line Connector Repair Kit, 90°	\$15
30338	90-97 Side Tank Filler Neck W/19 Gal Tank	\$80
30339	90-97 Side Tank Filler Neck W/16 Gal Tank	\$80



PLASTIC SIDE TANKS (6' BED)

30345	80-84, 17 Gal. W/2" Sender Hole	\$145
30348	85-96, 17 Gal. W/3-5/8" Sender Hole	\$145

STEEL SIDE TANK, 6' BED

30344	80-84, 16 Gal. W/2" Sender Hole	\$109
30346	85-86, 16 Gal. W/3-5/8" Sender Hole	\$109
30347	87-89, 16 Gal. W/3-5/8" Sender Hole	\$109
30349	90-96, 16 Gal. W/3-5/8" Sender Hole	\$109



SIDE TANK SENDER, 6' BED (GASOLINE)

30394	80-84 Pick-up, 17 Gal. Side Tank Sender	\$60
-------	---	------

SIDE TANK SENDER W/EFI, 6' BED (GASOLINE)

30396	85-86 Pick-up, 17 Gal. Side Tank Sender W/EFI	\$85
30359S	85-89 In Tank Fuel Pump Kit	\$59
30397	87-89 Pick-up, 17 Gal. Side Tank Sender W/EFI	\$90
30359EP	85-89 External Fuel Pimp Kit	\$99
30354A	85-86 302, Pump/Sender W/17 Gal Center Tank	\$109
30354C	85-86 F250 302, Pump/Sender W/17 or 19 Gal Tank	\$99
30359C	87-89 Fuel Pump/Sender W/ 17 Gal Side Tank	\$115
30361	90-97 In Tank Fuel Pump Kit	\$169



SIDE MOUNT TANK STRAPS (6' BED)

30378	80-96 Pick-up, Mounting Straps (pair)	\$25
-------	---------------------------------------	------

GAS CAPS

30364	Gas Cap, 80-86 Truck, Exc. 460	\$7
30365	Gas Cap, 83-86 Truck W/460	\$7
30366	Gas Cap, 87-88 Truck	\$8
30367	Gas Cap, 89-96 Truck	\$10



ENGINE COOLING & HEAT



6 CYLINDER RADIATORS

30600	1980-84, W/O AC	\$179
30602	1980-84, W/AC	\$225
30604	1985-92, W/O AC	\$130
30606	1985-96, W/AC & Manual Trans (exc. 92-96)	\$139
30608	1985-94, W/AC & Auto Trans (exc. 90-91)	\$139

302/351W V-8 RADIATORS

30610	1980-84, 302/351W, W/O AC	\$180
30612	1980-84, 302/351W, W/AC	\$195
30614	1980-84, 302/351W, W/AC & HD Cooling	\$195
30620	1985-96, 302/351W, W/1 Row Core	\$90
30622	1985-96, 302/351W, W/2 Row Core	\$125
30624	1985-96, 302/351W, W/2 Row & HD Cooling	\$125
30628	1995-96, 302 W/AC & HD Cooling	\$139

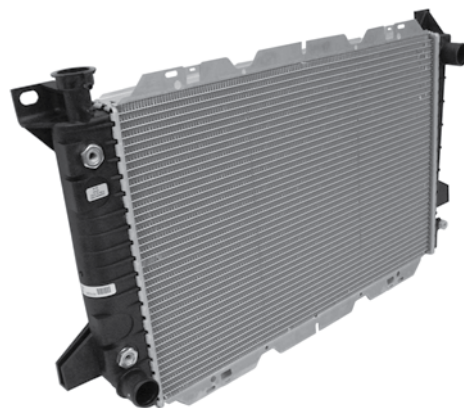

460 V-8 RADIATORS

30630	1983-88, 460 V-8	\$219
30632	1989-91, 460 V-8	\$139
30634	1992-94, 460 V-8	\$139

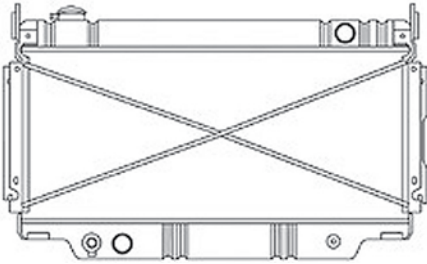

DIESEL ENGINE RADIATORS

30635	89-94, 7.3L W/O AC, W/O AOD	\$369
30636	89-94, 7.3L W/AC	\$369
30637	95-97, 7.3L All F-250/350	\$279

ALUMINUM RADIATOR

This Flex-a-lite aluminum radiator features internal fins to absorb heat more quickly, and then radiate it through external fins on the tanks. It is constructed of aluminum and is available with or without mounted electric fans. This radiator features two 1 in. diameter tubes made in a crossflow design for optimum cooling.

16616	80-84 Bronco, 300 6Cyl.	\$569.95
16617	80-84 Bronco, 300 6 Cyl W/Fan	\$711.24
16618	85-96 Bronco, 300 6 Cyl	\$569.95
16619	85-96 Bronco, 300 6 Cyl W/Fan	\$886.53
16620	80-96 Bronco, V-8	\$569.95
16621	80-96 Bronco, V-8 W/Fan	\$886.53
16626	80-96 F-Series, V-8	\$569.95
16627	80-96 F-Series, V-8	\$886.53

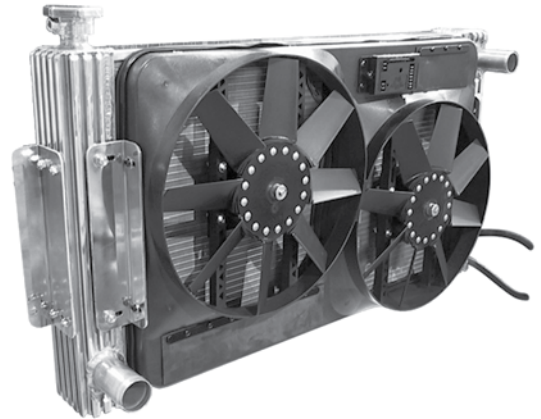

RADIATOR FAN SHROUDS

30694	302/351W V-8, OEM Fan Shroud	\$139
30695	87-90, 4.9L (300 six cyl) Super Cooling	\$150

ALUMINUM WATER PUMP

These FlowKooler aluminum water pumps feature the new patent pending MIRAKOOL 16 (M-16) FLOWKOOLER impeller which more than doubles the water flow rate at idle, yet drops back to stock output at 3500 RPM, avoiding too much water flow at high RPM.

16306	80-86 Bronco, 302 Aluminum Water Pump	\$85.95
16308	81 Bronco, 351W Aluminum Water Pump	\$104.95
16310	83-87 Bronco, 351W Aluminum Water Pump	\$84.95
16312	87-96 Bronco, 302 Aluminum Water Pump	\$94.95
16314	88-96, 351W Aluminum Water Pump	\$94.95
16320	429/460 Aluminum Water Pump	\$95.50

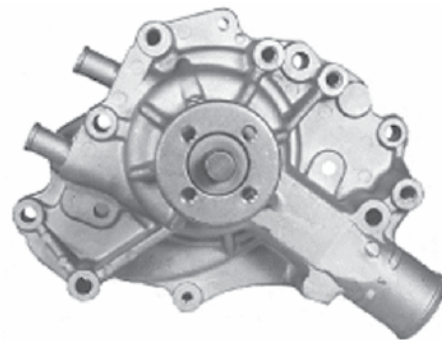
**THERMOSTATS**

Jeff's Bronco Graveyard and FlowKooler recommend Robertshaw thermostats. Back in 1916 Robertshaw made the first thermostats for the first American cars. Today, Robertshaw is still the first giving you their exclusive combination of quality features.

16390	160° Thermostat 302,351W,429,460	\$14
16392	180° Thermostat 302,351W,429,460	\$14
16394	180° Thermostat 351M, 400	\$16

THERMOSTAT HOUSINGS

30640A	1980-83, 300 CID Six Cylinder	\$12
30640B	1984, 300 CID Six Cylinder	\$12
30640C	1985-90, 300 CID Six Cylinder	\$11
30640D	1980-84, 302 V8	\$16
30640E	1985-94, 302 V8	\$12
30640F	1982-87, 351W V8	\$16
30640G	1988-94, 351W V8	\$12
30640H	1995-96, 302/351W V8	\$11
30460I	1980-83, 351M V8	\$13
30640J	1983-85, 460 V8	\$16
30640K	1986-89, 460 V8	\$16
30640L	1990-94, 460 V8	\$16



RADIATOR HOSES

300 CID 6 CYL. HOSES

30652	80-84 Upper Hose, 26 $\frac{3}{4}$ "	\$12
30652A	80-84, W/AC, Upper Hose	\$13
30652B	85-91, Upper Hose	\$12
30652C	92-96, Upper Hose	\$12
30652D	80-91, Lower Hose	\$13
30652E	92-96, Lower Hose	\$10



302/351W HOSES



30653	80-84, 302/351W Upper Hose	\$14
30653A	85-86, 302 Upper Hose	\$12
30653B	85-87, 351W Upper Hose	\$12
30653C	87-96, 302/351W Upper Hose	\$13
30653D	80-84, 302/351W Lower Hose, 26 $\frac{3}{4}$ "	\$12
30653E	80-84, 302/351W-W/AC, Lower Hose, 32 $\frac{1}{2}$ "	\$16
30653F	85-93, 302/351W Lower Hose	\$16
30653G	94-96, 302/351W Lower Hose	\$16
30653H	95-96, 351W W/Oil Cooler Lower	\$39

351M HOSES

30655	80-81, Upper Hose	\$14
30655A	80-81, Lower Hose	\$16

460 HOSES

30656	83-84 Upper Hose	\$13
30656A	85-96, Upper Hose	\$12
30656B	83-90, Lower Hose	\$14
30656C	90-96, Rad. to Oil Cooler	\$10
30656D	90-96, Engine to Oil Cooler	\$7

BY PASS HOSE

30645	80-96, 302/351W Bypass Hose	\$6
-------	-----------------------------	-----



BELTS

V-BELTS

300 CID 6 CYL

30450	80-87, 2WD: Fan, PS Belt	\$11
30450A	80-86, 2WD: Fan, PS W/AC	\$9
30450B	80-87, 4X4: Fan, PS Belt	\$10
30450C	80-87, 4X4: Fan, PS W/AC	\$10

302 CID V-8

30451	80-86, 2WD: Fan, PS Belt	\$12
30451A	80-86, 2WD: Fan, PS W/AC	\$8
30451B	80-86, 4X4: Fan, PS Belt	\$8
30451C	80-86, 4X4: Fan, PS W/AC	\$12

351W CID V-8

30452	83-85, 2WD: Fan, PS Belt	\$13
30452A	83-85, 2WD: Fan, PS W/AC	\$13
30452B	83-87, 4X4: Fan, PS Belt	\$13
30452C	83-87, 4X4: Fan, PS W/AC	\$13

400 CID V-8

30453	80-82, 2WD: Fan, PS Belt	\$12
30453A	80-82, 2WD: Fan, PS W/AC	\$8
30453B	80-82, 4X4: Fan, PS Belt	\$12
30453C	80-82, 4X4: Fan, PS W/AC	\$12

460 CID V-8

30455	83-86, Fan, PS Belt	\$10
30455A	83-86, Fan, PS W/AC	\$12

SERPENTINE BELTS

300 CID 6 CYL

30460	1987, W/AC	\$20
30460A	87-89, W/AC, Man. Trans.	\$22
30460B	87-95, W/AC	\$23
30460C	87-95, Serpentine Belt	\$26
30460D	1996, Serpentine Belt	\$26

302 CID V-8

30461	1987, Serpentine Belt	\$26
30461A	88-92, Serpentine Belt	\$25
30461B	93-96, Serpentine Belt	\$22

351W CID V-8

30462	88-92, Serpentine Belt	\$24
30462A	93-96 Serpentine Belt	\$27

IDLER PULLEY

30432	80-86, W/Dealer AC	\$20
30432A	80-86, W/Factory AC	\$22



**Serpentine Belt Route
W/O AC**

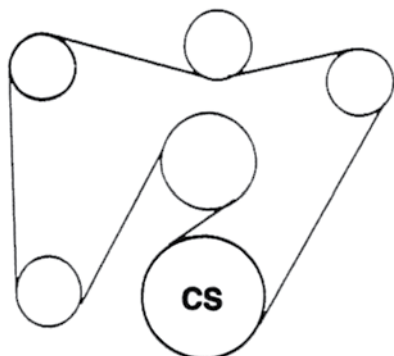

**Serpentine Belt Route
W/AC**

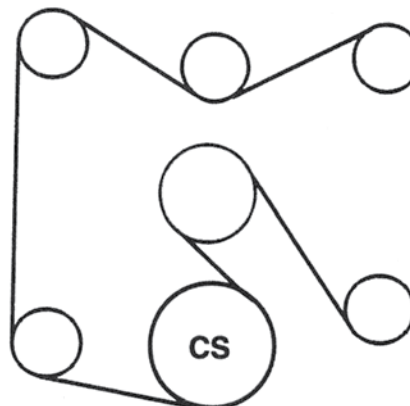



RADIATOR CAP

13 lb. radiator cap with safety lever pressure release.

10665	Radiator Cap, 13 lb. W/Safety Lever	\$6
10666	Radiator Cap, 13 lb. Std.	\$6

MOJAVE REPLACEMENT HEATER UNIT.

The Mojave heater unit is designed to simplify the task of providing heat and comfort to your ride. It eliminates the need to locate hard-to-find parts, or go through expensive rebuilds to get old units in working order. Its design offers several mounting options and the optional Plenum includes adjustable louvers and a flange for defroster ducting. The Mojave gets its heat from the vehicles cooling system (just like the stock unit) but has the advantage of fitting into a wide variety of confined spaces making it an ideal replacement unit.



17290	Mojave Heater Unit	\$175
17291	Optional Plenum For Mojave	\$46

HEAT BLOWER MOTORS

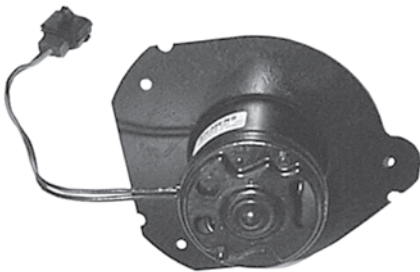

37210	Heater Motor, 1980-86 Bronco/PU	\$30
37212	Heater Motor, 1980-86 Bronco/PU W/AC	\$33
37213	Heater Motor, 87-96 Bronco/PU	\$33
37214	Heater Motor W/Wheel, 87-96 Bronco/PU	\$36
37218	Blower Motor Resistor	\$18
37219	HVAC Blower Motor Pigtail, 86-94	\$18

BLOWER MOTOR WHEEL

37215	Heater Motor Wheel, 80-86 W/O AC	\$18
37216	Heater Motor Wheel, 80-86 W/AC	\$23
37217	Heater Motor Wheel, 87-96 W/AC	\$18



**HEATER CORE**

37200	1980-86 W/O AC	\$28
37202	1980-86 W/AC	\$28
37203	1980-86 W/High Output AC	\$28
37206	1987-96 All	\$28

ACCUMULATORS

30676	1980-81 Bronco/PU AC Accumulator	\$59
30677	1982 Bronco/PU AC Accumulator	\$49
30678	1983-93 Bronco/PU AC Accumulator	\$35
30679	1994-96 Bronco/PU AC Accumulator	\$35

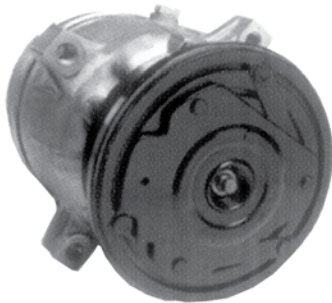
**AIR CONDITIONING COMPRESSORS**

30680	82-86 Bronco/PU 300 6 Cyl.	\$219
30681	1982-86 V-8 (rebuilt)	\$239
30683	1987 Bronco/PU (new)	\$239
30685	88 All;87-90 300 6 Cyl. (new)	\$259
30687	91-93 & 96 All (new)	\$175
30689	94-95 All;90-93 300 6 Cyl. (new)	\$179

AIR CONDITIONING CONDENSER

30670	AC Condenser 1980-93	\$99
30672	AC Condenser 1994-96	\$99

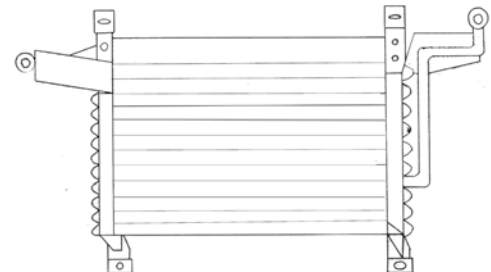

BELT TENSIONERS & PULLEY'S



30432	80-86 Idler Pulley, W/Dealer AC	\$20
30432A	80-86 Idler Pulley, W/Factory AC	\$22
30433	87-89 Idler Pulley, 302/351W	\$11
30433A	90-96 Idler Pulley, 302/351W, W/60A	\$18
30433B	90-96 Idler Pulley, 302/351W, W/AC	\$16
30434	87-93 Tensioner Pulley, 300 CID	\$18
30434A	87-96 Tensioner Pulley, 302/351W	\$18
30434B	93-96 Tensioner Pulley, 302/351W	\$13
30436	87-93 Auto Tensioner, 300 CID	\$45
30436A	87-92 Auto Tensioner, 302/351W	\$59
30436B	93-96 Auto Tensioner, 302/351W	\$49

AC BYPASS PULLEY.

Replaces your air conditioning pump & pulley while still retaining your current belt configuration. Will help increase horsepower by reducing drag on your belt system.

30478	83-87 AC Bypass Pulley, 302/351W	\$24
30479	88-89 AC Bypass Pulley, 302/351W	\$24
30480	90-96 AC Bypass Pulley, 302/351W	\$24
30482	93-97 AC Bypass Pulley, 7.3L Diesel	\$25
30484	90-96 AC Bypass Pulley, 300 Six Cyl.	\$24



WATER PUMP

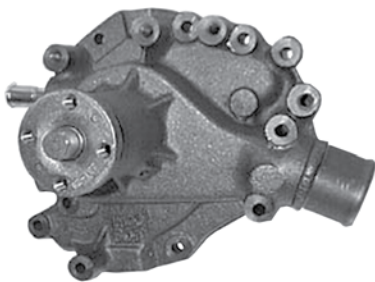

30646	80-82, 300 Six Cyl.	\$29
30646A	83-86, 300 Six Cyl.	\$35
30646B	87-92, 300 Six Cyl.	\$35
30646C	93-96 Truck, 300 Six Cyl.	\$35
30648	80-87, 302/351W	\$35
30648A	87-96, 302/351W	\$35
30650	80-82, 351M/400	\$35

TEMPERATURE SENDER

Brass sensor sends an accurate signal to your temperature gauge (gasoline engine application only). Made in USA.

10670	Temperature Gauge Sending Unit	\$10
-------	--------------------------------	------



FLEX-A-LITE



LOW PROFILE FLEX FAN

Designed for use on limited clearance applications. Low pitch reduces load on the engine which equates to higher performance and improved gas mileage.

16410 17" Low Profile Flex Fan \$30

6 BLADE RACE FANS

These all metal fans are built to sustain higher RPMs than standard OE fans, yet conform to most race specs. Flex-A-Lite race fans provide maximum airflow at low and high RPM and are inexpensive to replace.

16420	Steel Blade 15¼" Race Fan	\$37
16420A	Steel Blade 17½" Race Fan	\$35
16420B	Steel Blade 18¼" Race Fan	\$35
16422	Aluminum Blade 15¼" Race Fan	\$47
16422A	Aluminum Blade 17½" Race Fan	\$42
16422B	Aluminum Blade 18¼" Race Fan	\$47



NYLON FANS

Designed to be inexpensive and light, yet still provide maximum cooling. Lightweight nylon construction relieves stress on the water pump and bearings. Ideal for race and performance applications when cost or weight is a concern.

16430	15" Nylon Fan	\$27
16432	17" Nylon Fan	\$27
16433	18" Nylon Fan	\$27

ELECTRIC FANS

16440 14" Trimline Electric Fan (black) \$99

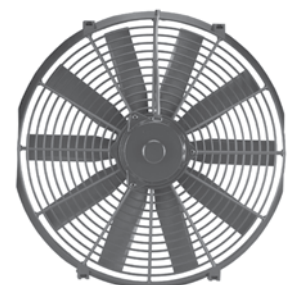

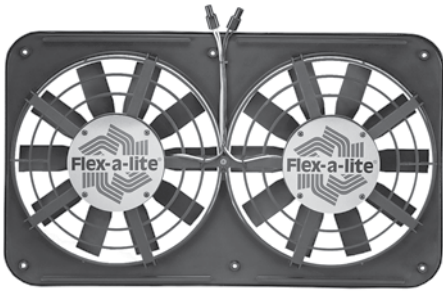

DUAL LOW PROFILE ELECTRIC FAN

Extremely low profile allows these fans to fit where others won't.

- | | | |
|-------|-----------------------------|-------|
| 16450 | Dual Low Profile Pusher Fan | \$319 |
| 16452 | Dual Low Profile Puller Fan | \$319 |

BLACK MAGIC ELECTRIC FAN

Provides constant cooling regardless of engine RPM with a high torque high RPM electric motor. Features include a built in control box with adjustable thermostat, A/C relay and manual switch connection.

- | | | |
|-------|------------------------|-------|
| 16461 | Black Magic Puller Fan | \$285 |
|-------|------------------------|-------|

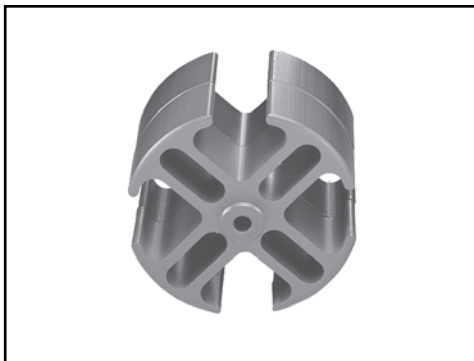

FAN SPACERS

- | | | |
|--------|-------------------------------|------|
| 16490 | 1/2" Fan Spacer (mill finish) | \$15 |
| 16491 | 1/2" Blue Fan Spacer | \$16 |
| 16491A | 1" Blue Fan Spacer | \$17 |
| 16491B | 2" Blue Fan Spacer | \$19 |

OIL COOLERS

Engine oil acts as a coolant as well as a lubricant. If oil is allowed to get too hot, horsepower drops, varnishes form, and oil starts to break down. Our new line of heavy duty oil coolers offer longer life to engines and components, and reduce stress created by high performance engine modifications.

- | | | |
|-------|--------------------------|-------|
| 16502 | Std. Oil Cooler Kit | \$79 |
| 16504 | HD Engine Oil Cooler Kit | \$169 |
| 16520 | In-line Fuel Cooler | \$49 |

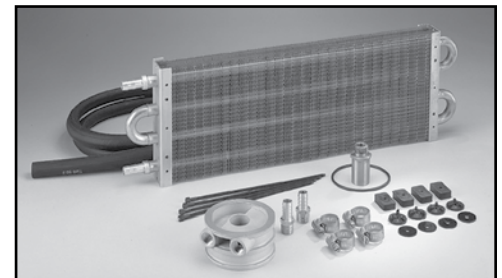

ENGINE PARTS

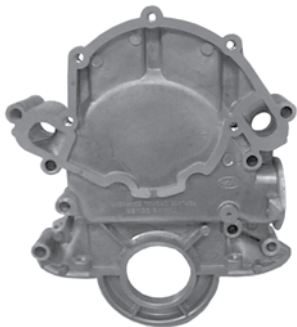

TIMING CHAIN COVER

30708	300 6 Cyl. Timing Cover	\$55
30712	1980-86 302,351W	\$60
30714	1987-96 302,351W W/Crank Trigger	\$75
30709	1980-96 460 Timing Chain Cover	\$75
30710	1980-86 302,351W Timing Pointer	\$18

MOTOR PLATES

30722	80-96 Man. Trans. 289,302,351W,300 6 Cyl.	\$45
30725	80-86 C-6 Auto Trans. 302/351W	\$47

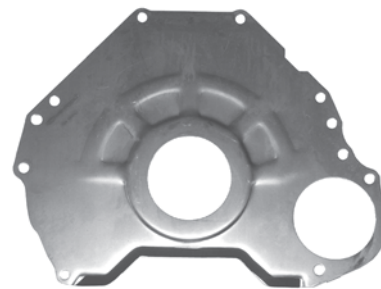

MOTOR MOUNTS



30506	80-84 300 6 Cyl. (pair)	\$40
30507	85-88 300 6 Cyl. (pair)	\$40
30508	89-92 300 6 Cyl. (pair)	\$40
30509	85-92 300 6 Cyl. Hydraulic (pair)	\$55
30510	1980-86 302/351W (pair)	\$24
30511	1987-96 302/351W (pair)	\$23
30500	Motor Mount Towers 302/351W (pair)	\$135
30512	Motor Mounts 351M (pair)	\$28
30514	80-82, 460 (pair)	\$35
30516	83-97, 460 (pair)	\$35

EXTREME DUTY MOTOR MOUNTS

These Extreme Duty motor mounts replace your original mounts and perform like a solid mount, without the vibrations and stress cracks often associated with solid mounts. These mounts incorporate a polyurethane bushing (similar to leaf spring bushings) to help dampen harmonics and vibrations.

30505	Extreme Duty Poly Motor Mounts 302/351W	\$109
-------	---	-------

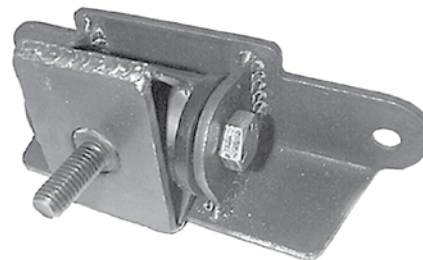



HARMONIC BALANCER

30400	1980-89, 300 6 Cyl.	\$90
30402	1980, 302	\$70
30403	1981, 302	\$70
30404	1983-95, 302	\$70
30407	1980-82, 351M	\$100
30408	1982-97, 351W	\$70
30409	1980-95, 460	\$70

VALVE COVERS (FOR NON-EFI ENGINES)

30780	Black W/Bronco Script	\$139
30781	Black W/302 Script	\$139
30782	Polished W/Bronco Script	\$139
30783	Black W/351 Script	\$139
30784	Chrome Valve Covers	\$35
30786	Chrome Dress Up Kit*	\$60

*Dress up kit includes: chrome valve covers, air filter, and breather.

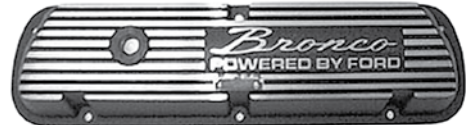
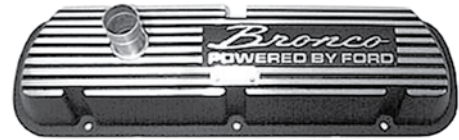

CHROME ACCESSORIES

Dress up your engine with these chrome goodies. Fits 289, 302, 351W. Dress up kit includes air filter, valve covers, and breather. Will not fit EFI engines.

10305	Chrome Air Filter.	\$30
30784	Chrome Valve Covers	\$35
30786	Chrome Dress Up Kit	\$60
10789	Chrome Oil Cap/Breather	\$7



VALVE COVER GASKETS

These re-usable valve cover gaskets feature a rubber outer shell that is vulcanized over a steel inner core for strength and longevity. Resists the pushing out or drawing in common with other types of gaskets.

30788	Valve Cover Gaskets, Pair (small block)	\$19
-------	---	------

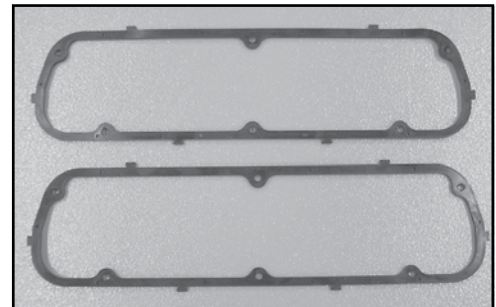

OIL PRESSURE SENDER

Oil pressure sender screws in to engine to give an accurate pressure reading to the oil gauge. Made in USA.

10152	Oil Pressure Gauge Sending Unit	\$13
10150	Oil Pressure Sender Extension	\$21

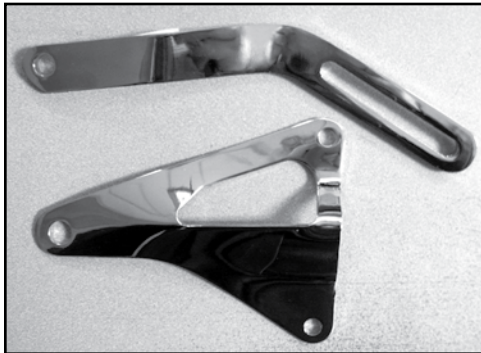
**CHROME ALTERNATOR BRACKETS**

Show or go. These alternator brackets are a welcome edition to any engine compartment. 2 piece set.

30742	Chrome Alternator Brackets	\$20
10742B	Black Alternator Brackets	\$15

MISCELLANEOUS

10762	Coil Bracket, Stainless Steel	\$17
10763	Coil Bracket, Black	\$13

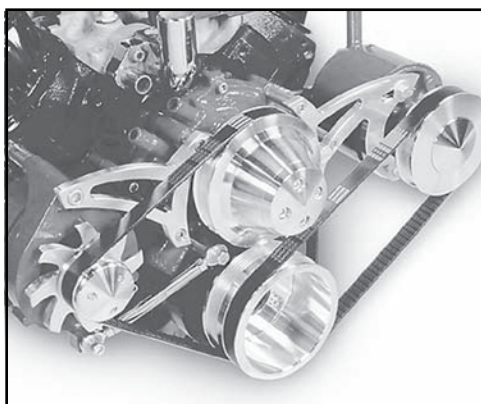

stainless coil bracket

**PULLEY KITS**

Billet pulley kit includes crank pulley, alternator pulley and water pump pulley.

Serpentine kit comes complete with stainless steel tensioning rods, ChromeMoly rod ends, pulleys, brackets and hardware.

30470	88-96, 302/351W Billet Pulley Kit	\$150
30496	88-93, 302 Serpentine Pulley Kit	\$655

STOCK DISTRIBUTORS

18562	74-87, 300 Six Cyl, Single Vacuum	\$79
18564	1987, 300 Six Cyl, No Vacuum	\$79
18567	89-91, 300 Six Cyl, Single Vacuum	\$79
18568	92-96, 300 Six Cyl, Single Vacuum	\$79
18572	74-84, 302 V-8, Single Vacuum	\$75
18574	81-83, 302 V-8, Single Vacuum	\$79
18576	86-91, 302 V-8, Single Vacuum, Cast Gear	\$79
18577	86-91, 302 V-8, Steel Gear	\$79
18582	75-88, 351W V-8, Single Vacuum	\$79
18584	88-91, 351W V-8, Single Vacuum	\$79
18586	92-93, 351W V-8, Single Vacuum	\$79
18590	351M, 400, 429, 460, Single Vacuum	\$79
18592	351M, 400, 429, 460, Dual Vacuum	\$79



HEI DISTRIBUTOR

Finally!! A high-performance, ruggedly built HEI distributor for your 289/302. Easy one wire hook up. Improved performance over stock electronic or breaker point distributors. Built-in 50,000-volt coil, premium cap with brass terminals, micro polished die-cast housing, both upper and lower bushings for added durability, and no voltage-reducing ballast resistor.

Note: Bronze distributor gear required for all roller cam applications.



18540	289/302 HEI Distributor, Blue Cap	\$139
18542	289/302 HEI Distributor, Black cap	\$139
18545	351W HEI Distributor, Blue Cap	\$139
18546	351W HEI Distributor, Black Cap	\$139
28550	351M/400, 460 HEI Distributor, Blue Cap	\$159
28552	351M/400, 460 HEI Distributor, Black Cap	\$169
10792	Spark Plug Wire Separators, Black	\$10

THROTTLE CABLES

30790A	80-82, 4.9L	\$29	30793	83-89, 351W	\$32
30790B	83-86, 4.9L	\$35	30794	80-83, 351M/400	\$26
30790C	87-89, 4.9L	\$29	30796	80-87, 460	\$26
30790D	90-96, 4.9L	\$28	30796A	88-91, 460	\$26
30792	80-86, 302	\$27	30796B	92-97, 460	\$42
30792A	85-89, 302/351W	\$37	30796D	83-91, 6.9L Diesel	\$35
30792B	90-91, 302/351W	\$23	30796E	92-96, 6.9L Diesel	\$35
30792C	92-97, 302/351W	\$19			





SLANT EDGE VALVE COVERS

Ford Racing valve covers. Turn heads with this new aggressive and modern look for your engine. As a result of innovative mold design, these die-cast valve covers offer more internal clearance for large valvetrain applications. They provide a totally personalized look. Tall, with a removeable baffle. Grommets and bolts included. Sold in pairs.

NOTE: NOT for use on engines with EFI manifolds.

10783J	289/302 W/Black Crinkle Finish	\$179
10783K	289/302 W/Ford Blue Finish	\$179
10783L	289/302 W/Cast Gray Finish	\$179
10783P	289/302 W/Polished Finish	\$179

ENGINE DRESS UP KITS

Ford Racing Engine Dress Up Kit.

289/302/351W Complete with valve covers, air cleaner and breather.

Note: will not fit under stock hood

10786A	289/302/351W Dress Up Kit, Chrome	\$149
10786B	289/302/351W Dress Up Kit, Black Crinkle	\$159
10786C	289/302/351W Dress Up Kit, Black/Chrome	\$149



FORD RACING AIR CLEANERS

10350	Air Cleaner, Chrome	\$57
10352	Air Cleaner, Chrome/Black	\$70
10354	Air Cleaner, Black Crinkle	\$70
10357	Center Nut, Chrome	\$8

TOOLS



HUB TOOL

Anyone who has ever worked on the front end of their truck knows how difficult it can be removing the spindle nuts. This tool makes the job a snap.

29625 Spindle Nut Socket \$15

BALL JOINT SPANNER SOCKET

This tool is a must for replacing the upper ball joint taper sleeve installed in the front housing.

12204SS Spanner Socket \$12

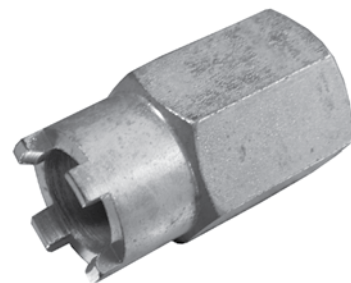

SPOT WELD CUTTER

19660 3/8" Spot Weld Cutter \$22

SPECIALTY DIFFERENTIAL TOOLS

29698	Differential ID/Repair Book	\$22
29689	Bronze Drift Punch 7/8" X 13"	\$20
29665	Heavy Duty Seal Puller	\$20
29668	Side Seal Install Tool	\$60
29660	Differential Bearing Puller	\$325
29675	9" Spanner Nut Tool	\$49



Bearing puller

429/460 BIG BLOCK

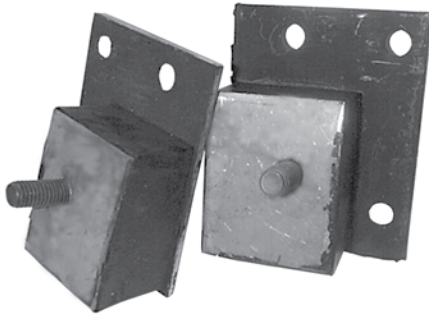

429/460 ENGINE CONVERSION MOUNTS

Installing a 429/460 in your truck? These mounts make the job a breeze. Mounts bolt directly to the engine block and use the stock frame perches. No need to relocate the transmission or transfer case. Will work for 1980-96 Bronco/F-150 with 302 and 351W.

30907 429/460 Conversion Engine Mounts \$119

429/460 ENGINE CONVERSION STANDS AND MOUNTS

These big block conversion kits include the frame stands and the engine mounts required to install a 429/460 in your vehicle.

30908	1980-96 Bronco/F150 W/300 6 CYL.	\$245
30909	1983-90 W/Diesel	\$245
30910	1980-82 Bronco/Pick-up W/ 351M-400	\$125

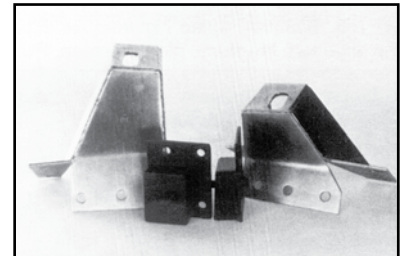

OIL PAN KITS

These oil pan kits include oil pan, dipstick, dipstick tube, pick-up tube and pick-up tube stud. Will fit all 429/460 engines installed in 1980-96 F-Series, Pick-ups and Broncos.

30900	Oil Pan Kit 429/460 7 Qt. System	\$219
30906	Oil Pan Kit 429/460 10 Qt. System	\$375



460 HEADERS

These chassis exit headers from L&L Products are loaded with features including: Precision CNC drilled and chamfered bolt holes, die formed concentric ports, oversize port openings, .090" wall tuned primary tubes, as well as being hydrostatic leak tested. The 1 3/4" dia. primary tubes send the exhaust through the 3" dia. collectors.

30950	80-87 Bronco, F-150/250	\$525
30952	88-93 Bronco, F-150/250, W/EFI	\$525
30954	80-87 F-350 W/Dana 60	\$525
30955	80-87 F-250/350 W/Air Injection	\$549
30956	88-97 F-350 Dana 60	\$549
30957	88-97 F-250/350 W/Air Injection, W/Out Straight Axle	\$549
30959	88-97 F-250/350 W/Air Injection, W/Dana 60	\$525

ALTERNATOR MOUNTING KITS

These mounting kits mount 45, 60, and 90 Amp alternators on 429/460 engines. Use #30920 kit to mount 45 and 60 amp alternator in 1980-86 Bronco/Pick-up. Use #30922 kit to mount 90 amp alternator in 1980-86 Bronco/Pick-up.

Note: All mounting brackets require a 1970 or later water pump and a 4 bolt hole harmonic balancer.

30920	Alternator Mounting Kit	\$90
30922	Alternator Mounting Kit	\$115

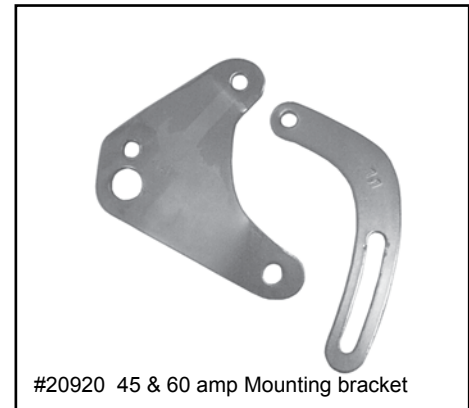

#20920 45 & 60 amp Mounting bracket

POWER STEERING AND A/C BRACKETS.

Power steering brackets mount stock type power steering pump to 429/460 engines in your late model F-Series truck/Bronco. #30926:

Air conditioning brackets are designed for square type, York and Tecumseh compressors in 1980-81 Bronco/Pick-up. #30928: fits FS6 aluminum ear mount compressor in 1982-88 Bronco/Pick-up.

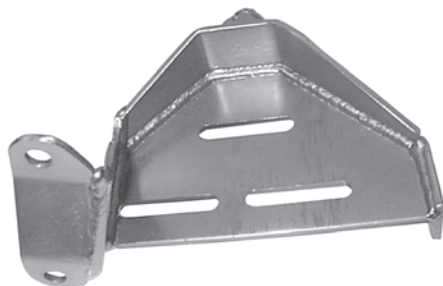

30924	P/S Pump Bracket, 80-88 W/6 CYL,302,351W	\$109
30925	P/S Pump Bracket, 80-82 W/351M	\$225
30926	A/C Mounting Kit, 1980-81 Bronco/Pick-up	\$145
30928	A/C Mounting Kit, 1982-88	\$145

FLYWHEEL AND CLUTCH ASSEMBLY

These flywheel and clutch assemblies will fit all stock type bell-housings and are designed for 429/460 engine swaps in 1980-96 Broncos & Pick-ups. Kit includes: 40 LB. NHRA approved machine steel billet flywheel, HD pressure plate, HD clutch disc, roller pilot bearing and all attaching hardware.

30934	Flywheel And Clutch Kit, 78 & Older Engines	\$599
30936	Flywheel And Clutch Kit, 79 & Newer Engines	\$599
30930	HD Flywheel Only, 78 & Older	\$385
30932	HD Flywheel Only, 79 & Newer	\$385

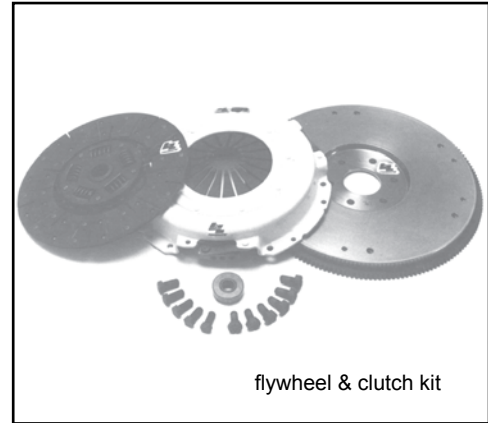

flywheel & clutch kit

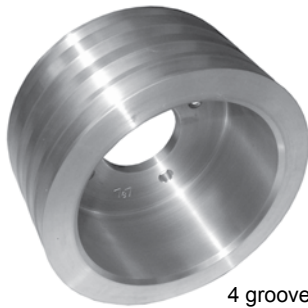

4 groove crank pulley

PULLEYS

These L&L Products pulleys are machined from high strength, heat treated aircraft grade aluminum alloy billet: 45,000 PSI tensile strength. Crankshaft pulley is smaller diameter than stock, reducing water pump speed at high engine RPM's.

30960	460 Water Pump Pulley 2 Groove	\$160
30961	460 Crank Pulley 2 Groove	\$130
30962	460 Crank Pulley 4 Groove	\$139

SERPENTINE BELT DRIVE KITS

Convert your 429/460 to a serpentine belt system. Matching aluminum pulleys are CNC machined from 6061-T6 aluminum. **Kit includes:** Alternator and power steering brackets. Crank pulley, water pump pulley, alternator pulley and power steering pump pulley. All spacers and mounting hardware included. Add a rebuilt Saginaw power steering pump for \$210 more.

20970	Serpentine Belt Kit (press fit PS pump)	\$535
20971	Serpentine Belt Kit (keyed PS pump)	\$535
20975	Add Saginaw P/S Pump	\$120



STARTER & ALTERNATORS

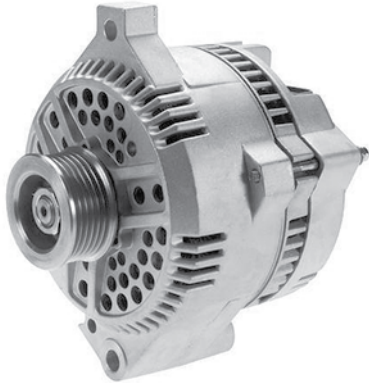

170 AMP OUTPUT ALTERNATORS

These units are assembled using only the highest quality new high amperage components. The manufacturer uses state of the art technology to measure the performance of every unit they manufacture. Output curves, engine idle speeds and pulley ratios are carefully considered to assure good drivability at idle and slow cruising speeds. All this translates to outputs of 70-80 amps at idle!

38601	1980-83 Bronco, 300 CID 6 Cyl, 1 V-Groove, Single Wire Hook-up	\$200
38603	1984-85 Bronco, 300 CID 6 Cyl, 2 V-Groove, Single Wire Hook-up	\$200
38605	1986-92 Bronco, 300 CID 6 Cyl, Serpentine Pulley, Single Wire Hook-up	\$195
38610	1980-83 Bronco, 302/351W, 1 V-Groove, Single Wire Hook-up	\$200
38612	1984-85 Bronco, 302/351W, 2 V-Groove, Single Wire Hook-up	\$200
38614	1986-92 Bronco, 302/351W, Serp. Pulley, Stock Plug Hook-up	\$195
38615	1986-92 Bronco, 302/351W, Serp. Pulley, Offset Mount, Stock Hook-up	\$195
38617	1993-96 Bronco, 302/351W, Serp. Pulley, Stock Plug Hook-up	\$195

HIGH TORQUE MINI STARTERS

Engine slow to crank? These high torque mini starters could be just the ticket. Available for automatic or manual transmission. Please specify year, engine size, transmission etc. . . when ordering.

38696	High Torque Mini Starter Auto Trans	\$69
38698	High Torque Mini Starter Manual Trans	\$69

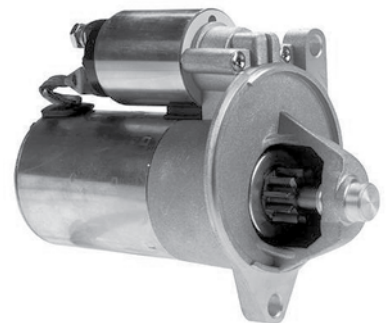

AUTO TRANS

FLEXPLATE

31100	Flexplate, 80-92 4.9L (300 CID)	\$45
31102	Flexplate, 1980 5.0L (302 CID)	\$68
31103	Flexplate, 1981 5.0L (302 CID)	\$40
31104	Flexplate, 82-89 5.0L (302 CID)	\$45
31105	Flexplate, 90-96 5.0L (302 CID)	\$42
31109	Flexplate, 81-82 5.8L (351W CID)	\$40
31110	Flexplate, 90-96 5.8L (351W CID)	\$75
31111	Flexplate, 80-83 5.8L (351M CID)	\$70
31112	Flexplate, 83-96 7.5L (460 CID)	\$40

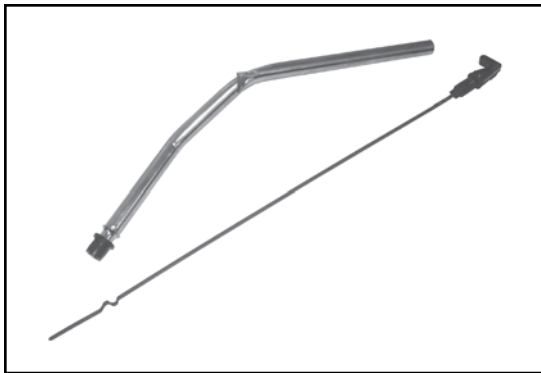

DIPSTICK & TUBE

Push-in style dipstick tube & dipstick for your big or small block C-6. Gold anodized dipstick tube and locking dipstick.

31165	C-6 Small Block Dipstick & Tube	\$39
31165A	C-6 Big Block Dipstick & Tube	\$39
31175	AOD Dipstick & Tube Assembly, 80-92	\$39
31195	E4OD Dipstick & Tube (small block), 89-97	\$39

TRANSMISSION ACCESSORIES

Cast aluminum transmission pan has 2 quart extra capacity and vented ribs for extra cooling and strength. Sold complete with filter adapter, gasket and mounting hardware. Transmission lines are pre-bent stainless tubes for a perfect fit every time.

31168	B&M Aluminum Trans Pan (C-6 only)	\$149
31176	AODE/AR700W Trans Pan	\$189
31180	E4OD/4R100 Trans Pan, 87-96	\$189
31190	1992 E4OD Trans Cooler Lines	\$75



OIL COOLER

The #1 cause of automatic transmission failure is overheating. Keep yours cool with these B&M Super Coolers.

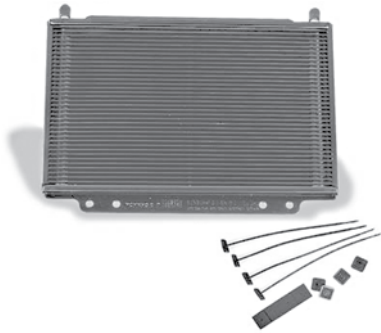

11156	B&M Super Cooler, 9,800 BTU	\$59
11157	B&M Super Cooler, 13,000 BTU	\$65
11158	B&M Super Cooler, 14,000 BTU	\$75

WINTERS SIDEWINDER SHIFTER

The sidewinder is Fail-Safe! It's mechanically impossible to accidentally shift into reverse from any forward gear. A sturdy, steel guard bars the shifting rod from all other positions except first, second, or third. When you want reverse, only you can put it there. The Sidewinder can be installed on any street, strip or off-road transmission and is available in both conventional and reverse shift patterns.

15" long x 5" wide x 11" tall. All shifters include basic shifter, 5' cable, housing and necessary hardware to mount to the transmission.

11180	C4 Winters Shifter	\$205
11181	C4 Reverse Gate Winters Shifter	\$205
21190	C6 Winters Shifter	\$205
21194	C6 Reverse Winters Shifter	\$210
31195	E4OD Winters Shifter	\$205
31196	AOD Winters Shifter	\$205

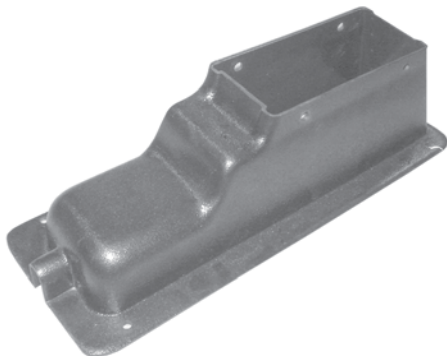
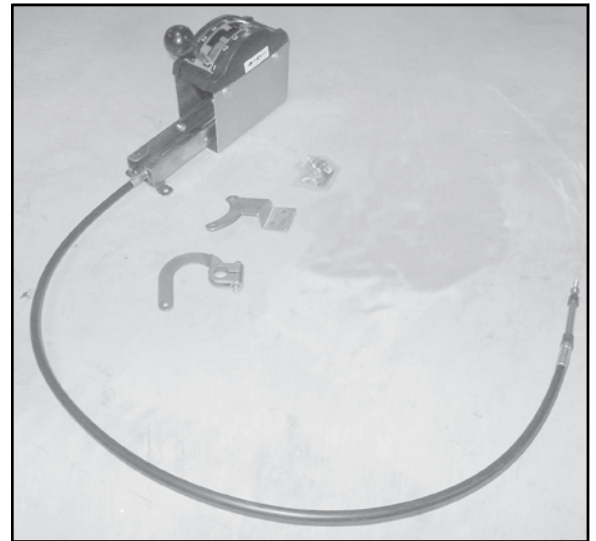

WINTERS SHIFTER HOUSING

11182	Shifter Housing For Winters Shifter	\$30
11186	Park Safety, Back-up Light Switch	\$70

NEW PROCESS 435

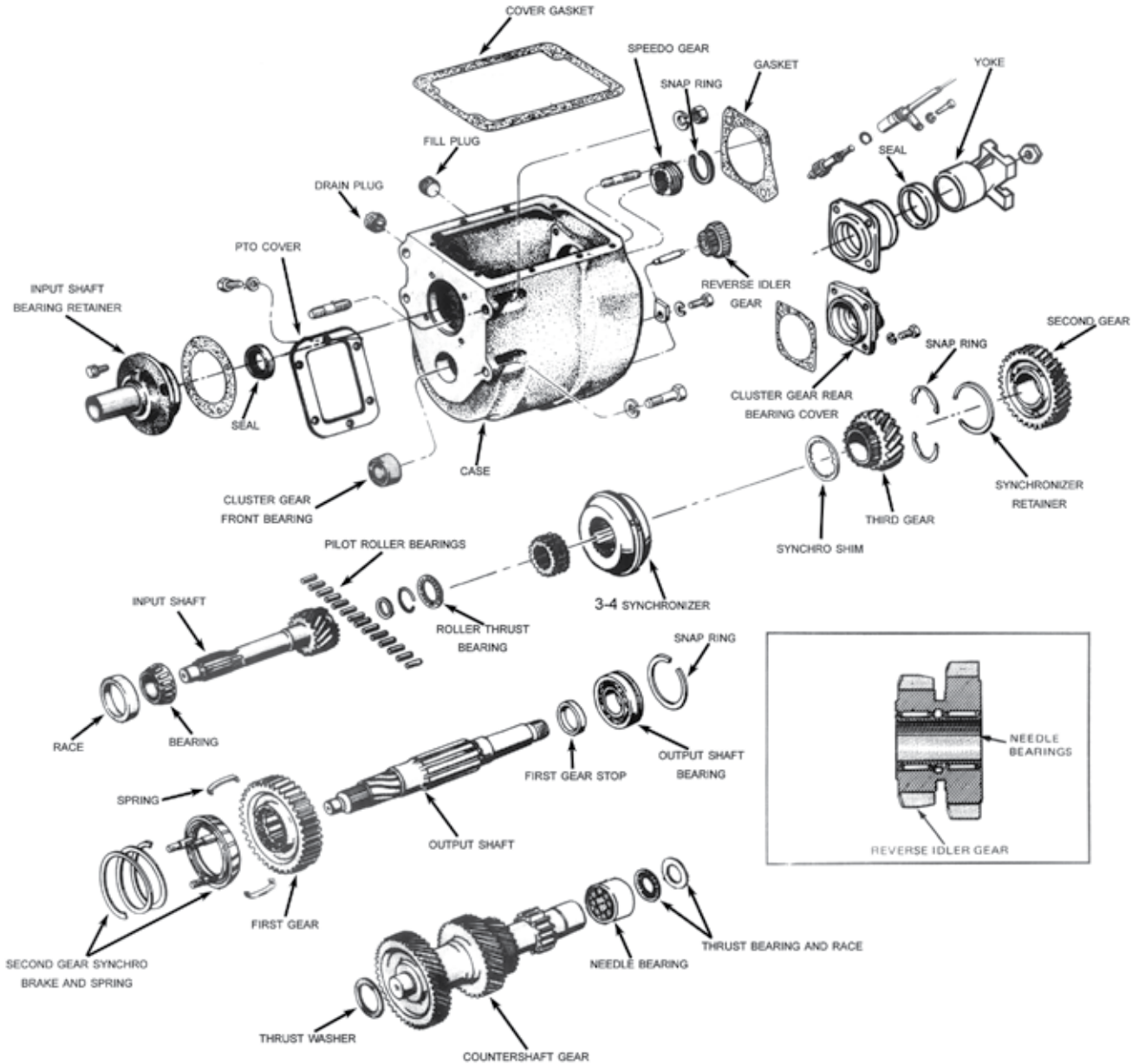

BORG WARNER T-18

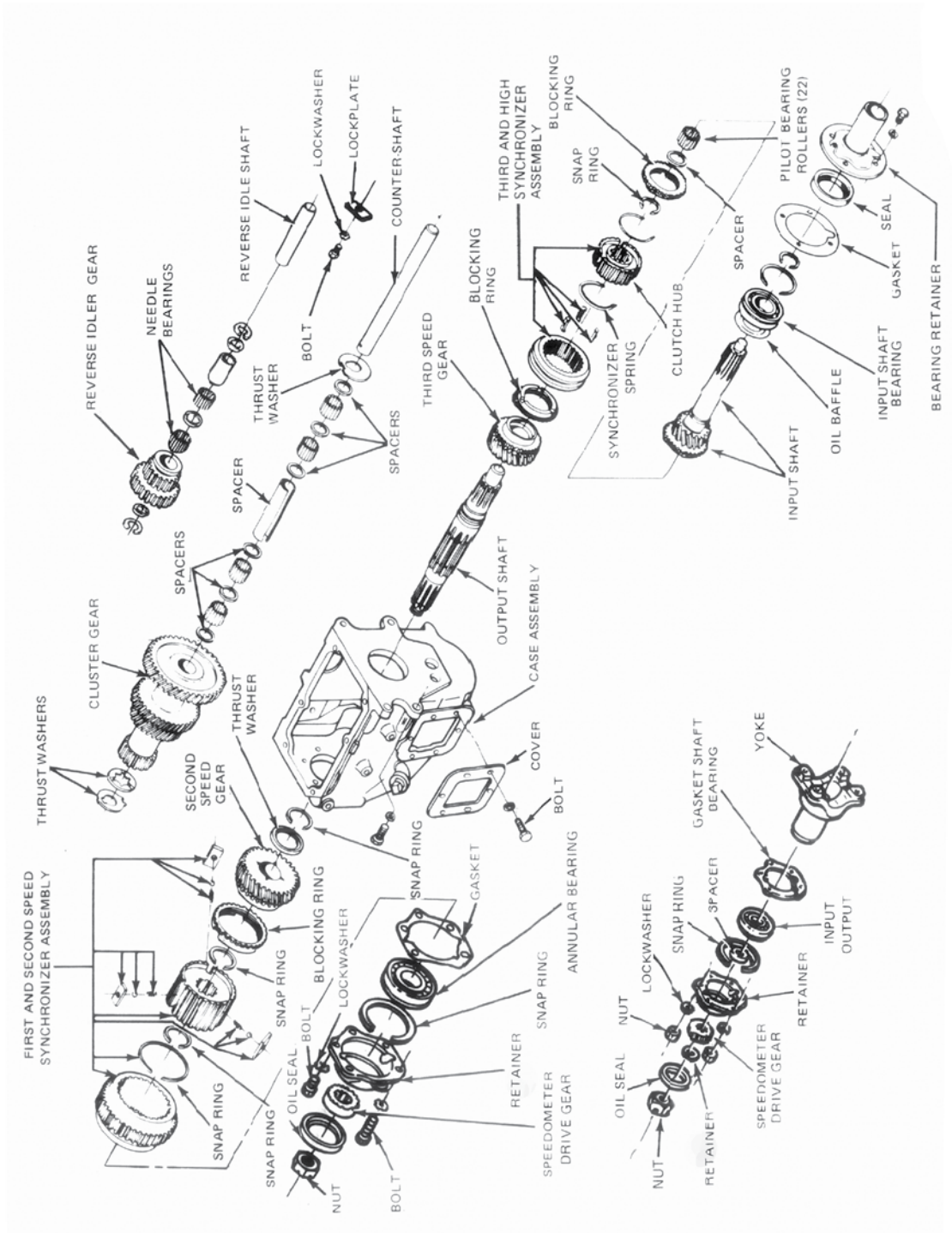

MANUAL TRANSMISSION

REBUILT NP435 TRANSMISSION

Leave the dirty work to us with one of our completely rebuilt NP435 transmissions. We replace all bearings, seals, gaskets and synchronizer assemblies in each of our rebuilt units. Or, if you prefer to get your hands dirty, we offer the bearing & seal overhaul kits. The overhaul kit includes all bearings and seals. The master kit adds the synchro assemblies.

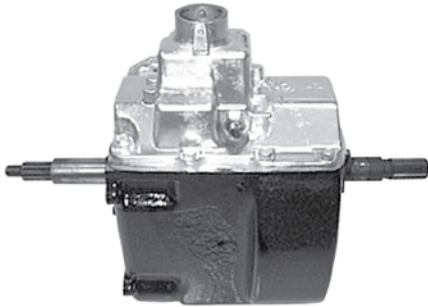

21003	Rebuilt NP435	\$885
21006A	NP435 4 Spd Overhaul Kit	\$98
21006	NP435 4 Spd Master Overhaul Kit	\$165
21006B	NP435 4 Spd Gasket & Seal Kit	\$19
21006C	NP435 Shift Tower Overhaul Kit	\$15

TRANSMISSION OVERHAUL KITS

21011A	Borg Warner T-18 Rebuild Kit	\$109
21011	Borg Warner T-18 Master Kit	\$159
31011	81-Up SROD Overdrive Kit	\$70
31012	81-Up SROD Overdrive Master Kit	\$105
31012A	81-Up RUG Overdrive Master Kit	\$105
31013	88-Up 5 Spd Mazda M5R2 Rebuild Kit	\$160
31014	88-6/90 Mazda M5R2 Master Rebuild Kit	\$210
31015	7/90-Up Mazda M5R2 Master Rebuild Kit	\$205
31016	87-Up ZF Basic Bearing & Seal Kit	\$110

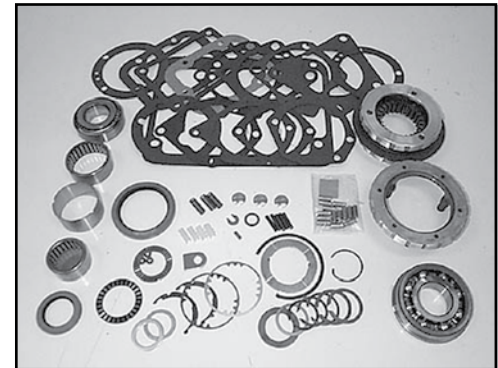

MANUAL TRANSMISSION HARD PARTS

21007A	NP435 Input Gear	\$90
21004	NP435 Front Bearing Retainer	\$30
21012	T18/19 Front Bearing Retainer	\$35

STANDARD FLYWHEEL

31090	Flywheel, 1981-96 300 6Cyl.	\$99
31092	Flywheel, 1980 V-8 302	\$119
31093	Flywheel, 1981-96 V-8 302	\$119
31094	Flywheel, 1981-96 V-8 351W	\$119
31096	Flywheel, 1987-97 V-8 460	\$119

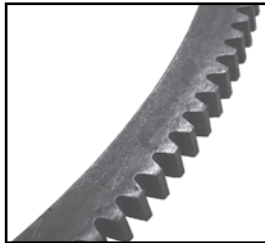

FLYWHEEL RING GEAR

31082	Ring Gear V-8 300,302,351W	\$20
31083	Ring Gear V-8 351M	\$20
31084	Ring Gear V-8 460	\$20

DIESEL FLYWHEEL (SOLID)

LuK's solid flywheel replacement for 7.3-liter Fords is engineered as a bolt-in replacement. It provides increased torque capacity for vehicles originally equipped with dual-mass flywheels, and later models equipped with single-mass flywheels. Solid flywheels must be replaced with the LuK clutch kit designed for the solid flywheel option. They cannot be used with the original-equipment clutch and disc. They also cannot be used with a LuK clutch kit designed for use with a dual-mass flywheel.

31393	87-94 7.3L W/O Turbo	\$290
31394	83-94 7.3L W/Turbo	\$295
31395	94-97 7.3L W/Turbo	\$305

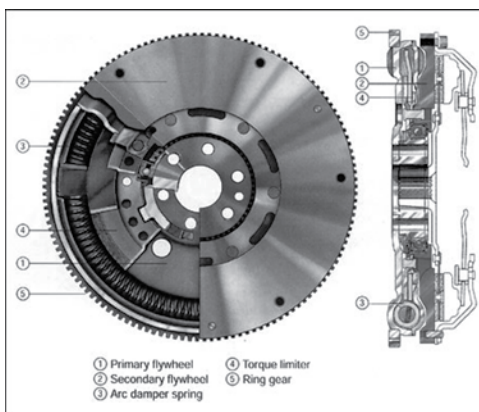
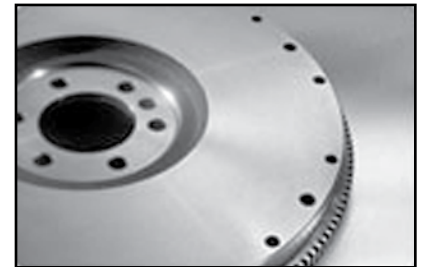

DIESEL FLYWHEEL (DUAL MASS)

The dual-mass flywheel is designed to absorb engine vibrations before they are transmitted to the driveline. This is achieved by splitting the conventional flywheel into two sections: a primary section, which bolts to the crankshaft, and a secondary section, onto which the clutch is bolted.

The primary section of the flywheel contains springs to isolate engine vibrations and a torque-limiting device to prevent engine and transmission damage. The torque-limiting package allows the primary section of the flywheel to turn independently from the secondary section, saving the driveline and transmission from damage.

31390	1987 6.9L Dual Mass Flywheel	\$695
31392	87-94 7.3L Dual Mass Flywheel	\$675

CLUTCH



LUK REPSET.®

LuK RepSets® are undoubtedly the highest quality line of clutch replacement sets on the market. LuK designs and manufactures clutch systems for OE vehicle manufacturers throughout the world. LuK clutches and discs undergo rigorous testing at each step in the production process. Their reputation for producing high-quality products continues to lead the way. Each precision matched set includes: pressure plate, disc, throw-out bearing, pilot bearing, spline tool, and lubricant.

300 6 CYL.(4.9L) CLUTCH SET

31220	80-82, W/10" Clutch	\$159	31228	87, W/11" Clutch	\$165
31221	80-82, W/11" Clutch	\$165	31230	88-93, 4spd. W/10" Clutch	\$145
31222	83, W/10" Hydraulic Clutch	\$159	31231	88-93, 4spd. W/11" Clutch	\$165
31223	83, W/11" Mechanical Clutch	\$165	31233	88-92, 5spd. W/10" Clutch	\$145
31224	84-86 W/10" Clutch	\$159	31234	88-92, 5 spd. W/11" Clutch	\$165
31225	84-86, W/11" Clutch	\$165	31236	93-94, 5 spd. W/10" Clutch	\$170
31227	87, W/10" Clutch	\$159	31237	93-97, 5 spd. W/11" Clutch	\$175

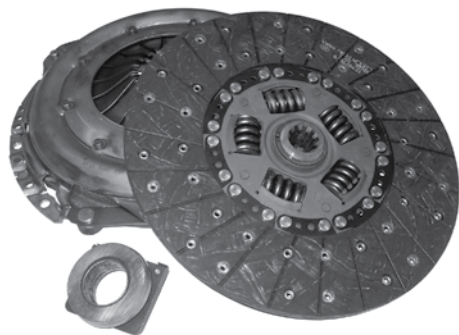

302 V-8 (5.0L) CLUTCH SET

31256	80-82, W/10" Clutch	\$165
31242	80-83, W/11" Clutch	\$179
31243	84-86, W/10" Clutch	\$155
31244	84-86, W/11" Clutch	\$165
31246	87, W/11" Clutch	\$170
31248	88-93, 4 spd. W/11" Clutch	\$169
31252	88-92, 5 spd. W/11" Clutch	\$165
31254	93-97, 5 spd. W/11" Clutch	\$185

351W V-8 (5.8L) CLUTCH SET

31256	1983, W/11" Clutch	\$165
31257	84-86, W/10" Clutch	\$145
31259	87, W/11" Clutch	\$165
31260	88-92, 4 spd. W/11" Clutch	\$169
31262	88-92, 5 spd. W/11" Clutch	\$165
31264	93-94, W/11" Clutch	\$185
31266	95-98, W/12" Clutch	\$239

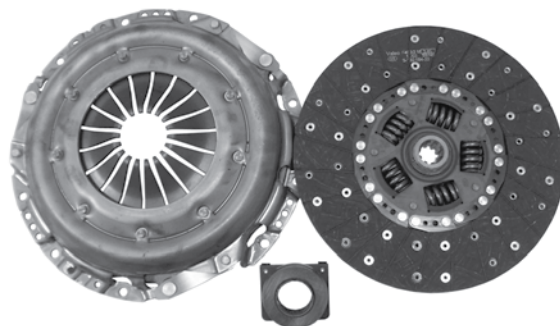

6.9L DIESEL CLUTCH SET

31267	83-86, W/11" Clutch	\$199
31268	83-87, W/12" Clutch	\$225
31269	87, 4 spd. W/11" Clutch	\$199
31270	87, 5 spd. 11" Clutch	\$219

7.3L DIESEL CLUTCH SET

31271	87-94, W/12¼" Clutch	\$369
31272	87-94, W/11" Clutch	\$219
31273	87-94, W/12" & Dual Mass	\$309
31274	94-97, W/13" & Solid Flywheel	\$335
31275	87-94, W/12¼" & Dual Mass	\$349

460 (7.5L)

31280	83-87 4 spd. W/11"	\$165
31281	83-87 12" Upgrade Clutch Set	\$198
31282	87-98 5 spd W/12¼" Clutch	\$239

LuK PRO GOLD SERIES

The LuK PRO GOLD SERIES sets the standard for clutch performance with parts designed specifically for extreme applications. LuK engineers established new specifications to improve clutch performance under extreme conditions and heavy usage, and then built LuK RepSet PRO GOLD SERIES to meet them. A new diaphragm spring clutch produces a specific clamp load that exceeds the requirements for the products intended use. As the clutch wears during normal operation, clamp load increases, peaks in mid-life and decreases gradually as shown on the clutch graph (as compared to other clutches on the market).

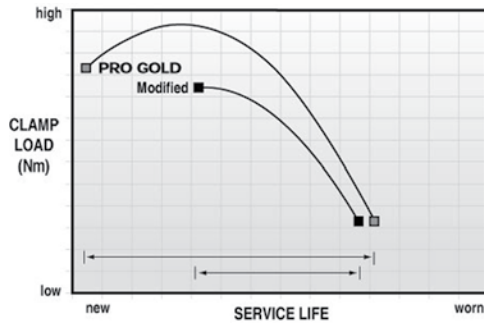

PRO GOLD 300 6 CYL. (4.9L)

31226	84-86, W/11" Clutch	\$226
31229	87, W/11" Clutch	\$226
31232	88-93, 4 spd W/11" Clutch	\$226
31235	88-92, 5 spd W/11" Clutch	\$226
31238	93-94, 5 spd W/11"	\$226
31240	95-97, PRO GOLD Set	\$226

PRO GOLD 302 (5.0L)

31245	84-86, W11" Clutch	\$226
31247	87, W 11" Clutch	\$236
31249	88-93, 4 spd W/11" Clutch	\$226
31253	88-92, 5 spd W/11" Clutch	\$226
31255	93-97, PRO GOLD Set	\$226

PRO GOLD 351W (5.8L)

31258	84-87 W/11" Clutch	\$226
31261	88-92, 4 spd W/11" Clutch	\$226
31263	88-92, 5 spd W/11" Clutch	\$226
31265	93-94, PRO GOLD Set	\$226

PRO GOLD 460 (7.5L)

31283	87-98, 5 spd W/12¼" Clutch	\$295
-------	----------------------------	-------

CLUTCH COMPONENTS



CLUTCH FORK

31320	80-82, 300 6 Cyl. Fork	\$25
31321	83, 300 6 Cyl. Fork	\$25
31322	84-96, 300 6 Cyl. Fork	\$24
31323	80-83, 302 Fork	\$25
31324	84-94, 302 Fork	\$25
31326	84-94, 351W Fork	\$25
31327	80-83, 351M Fork	\$25
31328	84-87, 6.9L Fork	\$26
31329	87-97, 7.3L Fork	\$32

HYDRAULIC CLUTCH COMPONENTS

31330	83-87, Clutch Master Cylinder	\$99
31332	88-91, Clutch Master Cylinder	\$79
31334	92, Clutch Master Cylinder	\$84
31336	93-97, Clutch Master Cylinder	\$84
31340	84-92, 4 spd Slave Cyl.	\$69
31342	93, 4 spd Slave Cyl.	\$74
31344	88-92, Slave Cyl.	\$89
31346	93, 5 spd Slave Cyl.	\$89
31348	83-98, Slave Cyl.	\$65
31349	84-86 Bronco/F-150, Hydraulic Line	\$26
31349A	83-88 F250/350, Hydraulic Line	\$26
31349B	88-91 Bronco/F-150, Hydraulic Line	\$35
31350	92-96 Bronco/F-150 Hydraulic Line	\$39

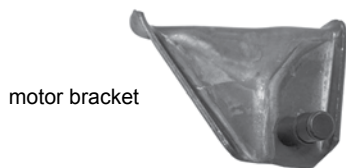
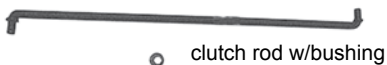

CLUTCH LINKAGE

31037	80-84, Clutch Rod W/Bushings	\$40
31038	80-85, Clutch Rod Bushing	\$8
31058	Equalizer Bar Bushing Kit	\$11
31060	Clutch Adjusting Rod	\$18
31063	302/351W Motor Bracket	\$60
31064	351M Motor Bracket	\$89
31066	351M/400 Frame Bracket	\$84
31067	302/351W Frame Bracket	\$75

TRANSFER CASE



BEARINGS & SEALS

Quiet that growling transfer case with one of our complete bearing and seal kits. Includes all bearings and seals needed to assemble your T-case.

31616	New Process 205 Bearing & Seal Kit	\$139
31620	New Process 208 Bearing & Seal Kit	\$85
31630	Borg Warner 1345 Bearing & Seal Kit	\$65
31640	Borg Warner 1356 Bearing & Seal Kit	\$89

SEALS & GASKETS

If you don't need all of the bearings for your transfer case, but you would like it to stop dripping in the driveway, try one of our gasket and seal kits.

31618	New Process 205 Gasket And Seal Set	\$39
31622	New Process 208 Gasket And Seal Set	\$22
31632	Borg Warner 1345 Gasket & Seal Kit	\$18
31642	Borg Warner 1356 Gasket & Seal Kit	\$30

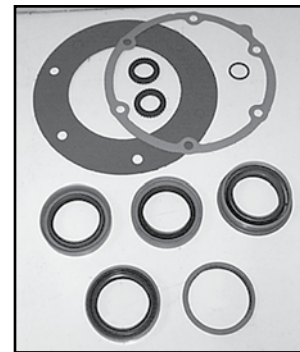

transfer case motor

REPLACEMENT PARTS

31626	New Process 208 Chain	\$99
31635	Borg Warner 1345 Chain	\$84
31645	Borg Warner 1356 Chain	\$105
31648	88-90 T-Case Actuating Motor	\$99
31650	91-97 T-Case Actuating Motor	\$99
31675	7 Tooth Speedo Driven Gear, 1356	\$10

TRANSFER CASE LINKAGE

31611	Replacement Transfer Case Linkage	\$149
-------	-----------------------------------	-------



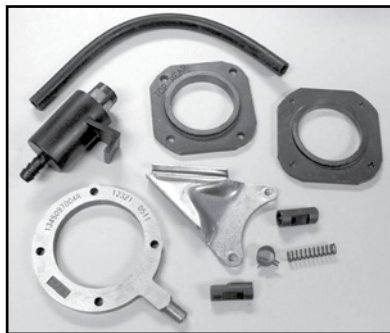

1356 OIL PUMP KIT

This kit includes all serviceable parts for the oil pump area of a Borg Warner 1356 transfer case.

31641 Pump Kit BW1356 Transfer Case \$45

TRANSMISSION/TRANSFER CASE MOUNT

31609	80-83 Bronco/F-150 Mount W/NP 205(OEM)	\$19
31606	80-86 Bronco/F-150 Mount (OEM)*	\$15
31607	87 Bronco/F-150 Mount (OEM)	\$19
31608	88-91 Bronco/F-150 Mount (OEM)	\$15

*Fits all 80-86 W/Manual trans. All 80-86 W/300 6 cyl. and 80-86 W/C-6 or AOD

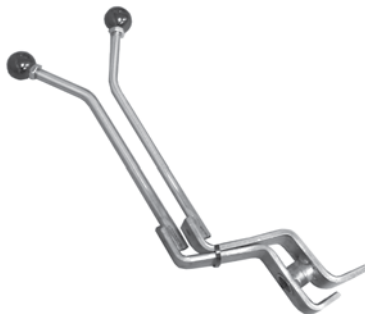

TWIN STICK SHIFTER

Stainless steel construction shifter includes mounting hardware and installation instructions.

21610	NP205 Twin Stick Shifter	\$128
11590	Twin Stick Shifter Boot	\$23

FLANGES & MISC

22486	NP205 U-Bolt Style Yoke, 1410*	\$75
22489	NP205 CV Style Yoke, 1310 Series*	\$55
22491	NP205 CV Style Yoke, 1330 Series*	\$67
22493	Conversion Seal For All Yokes	\$8
22494	NP205 U-Bolt Yoke, 1330 Series*	\$59
21620	Transfer Case Shifter Boot	\$30

*all of our NP205 yokes require the use of #22493 conversion seal



CV Flange



transfer case boot

NP205 Transfer Case

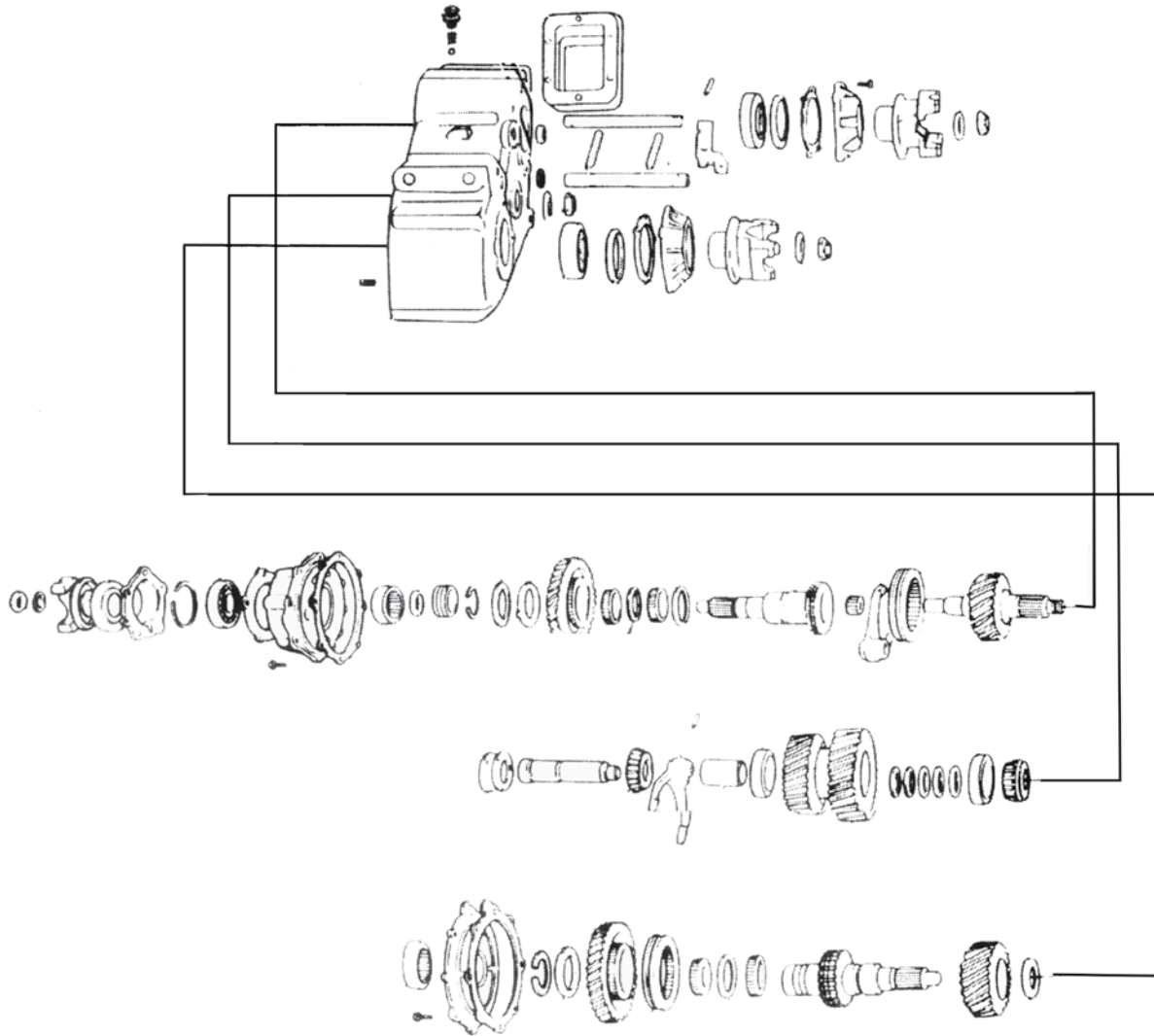

REBUILT NP205 TRANSFER CASE

With its gear driven design and rugged reputation, the New Process 205 transfer case is easily one of the best transfer cases ever offered. Replace yours with one of these completely rebuilt units. Each one has had all bearings, seals, and necessary hard parts replaced.

21604 Rebuilt NP205 Transfer Case

\$699

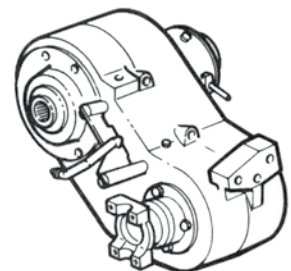

208 Transfer Case

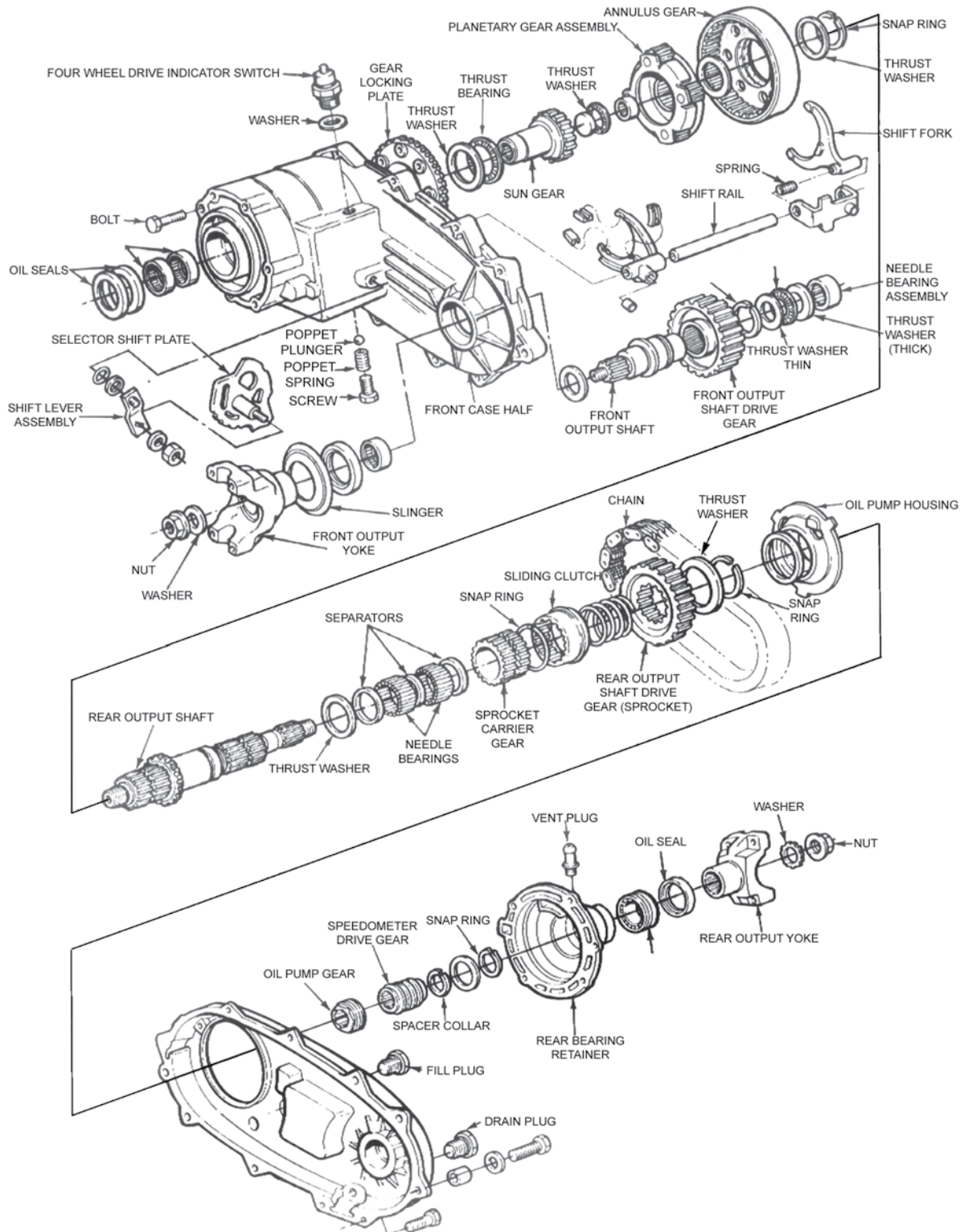

© Ford Motor Co.

1345 Transfer Case

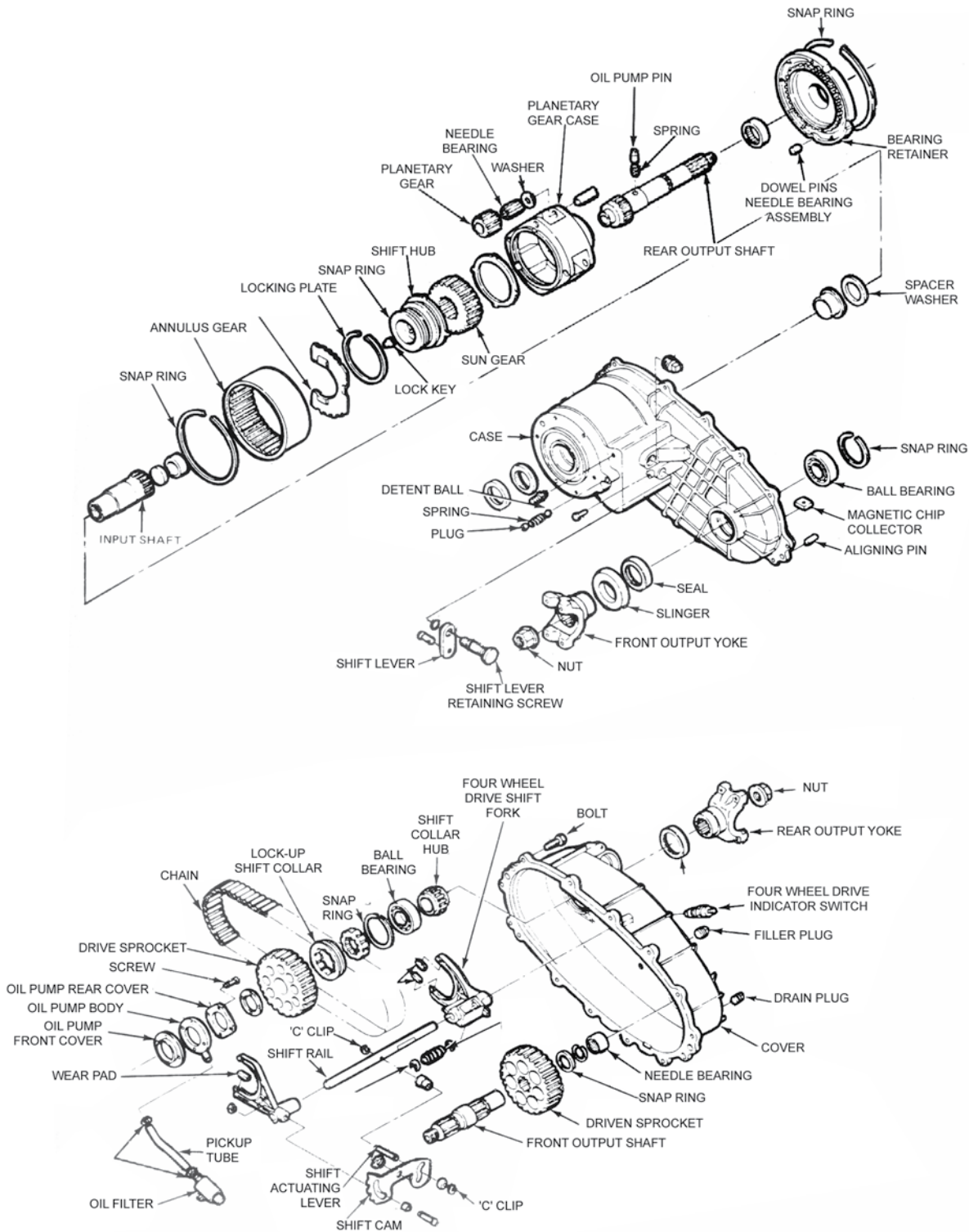

© Ford Motor CO.

Check out the low ratio Atlas transfer case.

The Advance Adapter Atlas transfer case is the ultimate in gearing and strength. These units are the solution for combining both on and off road performance. These units can be found in daily driven vehicles, all the way up to the extreme rock crawling vehicles. When you want or need peace of mind on the trail, in the rocks, on the sand or in the mud. The Atlas is the transfer case for you.

The solid, one piece case design is manufactured from 356-T6 heat-treated aluminum alloy. This material is also used for the structural access cover and all other exterior components. The massive gears are helical cut and synchro-equipped for quiet performance and "shift-on-the-fly" capability. These gears are supported by needle bearing elements, precision matched to strong 8620 shafts. The ruggedly designed output shafts are amply supported by large tapered bearing sets. The Atlas also features a unique twin stick design to deliver crisp, quiet operation. The Atlas has been tested and proven to handle 900 plus ft./lbs.

Features

- Helical cut gears
- Gear driven
- Full complement of Bearings
- Solid one piece case design utilizing 356-T6
- Synchronized Shifting
- Large Rear Output Shaft
- OEM Speedometer Gear
- Twin Stick for enhanced offroad capabilities
- Complete unit

Benefits

- Stronger and quieter than reduction planetaries
- No chain stretch
- No shaft to bore contact for strength and efficiency
- Stronger than two piece split case design
- Shift-on-the-fly capabilities
- Non-twisting and bulletproof
- Easy connection to existing components
- Front or rear wheel drive low range capability
- Fully assembled unit ready to be installed.

ATLAS TRANSFER CASE

The ultimate off-road transfer case. Rugged gear driven design. 900 lbs/ft. torque rating. Choose from many low range gear ratios. Unique twin stick shifter gives you the ability to engage front and rear axle independently in low range.

21402	Atlas 2.0:1 Ratio	\$2195
21404	Atlas 3.0:1 Ratio "Highlander"	\$2195
21406	Atlas 3.8:1 Ratio "Ultra Low"	\$2195
21408	Atlas 4.3:1 Ratio "Extreme Low"	\$2265
21410	Atlas 5.0:1 Ratio "Crawler"	\$2265
21412	Atlas 6.0:1 Ratio "Super Crawler"	\$2275
21414	Atlas 4 Spd Transfer Case	\$2895
31525	Ranger Overdrive Unit	\$1345
31550	NV4500 Swap Kit	\$659
31555	NV4500 Transmission	\$2500

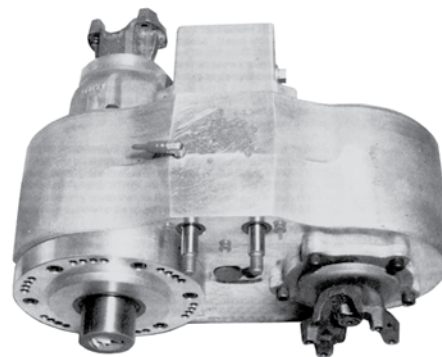

DANA 44 FRONT ENDS

REBUILT IFS 3RD MEMBERS

Front differential giving you problems? What could be easier than bolting in one of our rebuilt units? These units have been rebuilt with all new bearings, seals, shims, ring & pinion and carrier, as well as being professionally set-up by our own in house specialist. Just choose the gear ratio and style (Trac-Loc or open). NOTE: \$100 core charge applies.

32002	Rebuilt 3.54 W/Open Case	\$750
32003	Rebuilt 3.54 W/Trac-Lok Case	\$949
32004	Rebuilt 3.54 W/Detroit Locker	\$1199

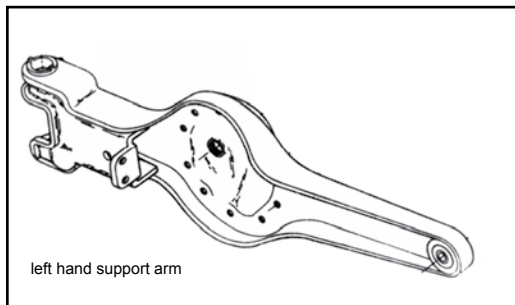
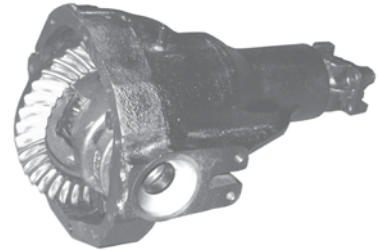

NEW!!! TWIN TRACTION BEAM SUPPORT ARMS

Bend or break one of the support arms in your truck? Must have been some kind of ride. These OEM support arms will get you up and running again.

32007	IFS Support Arm, LH	\$279
-------	---------------------	-------

What's that? You broke the other side too? Not a problem. We've got you covered.

32008	IFS Support Arm, RH	\$249
-------	---------------------	-------

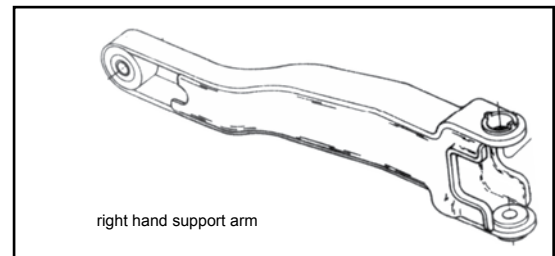

BEARING KITS.

Gear install kit includes: Pinion bearings, pinion shims, pinion seal, lock nut and cover gasket. **Overhaul kit includes:** All above parts and adds carrier bearings, axle bearing & seal and shims.

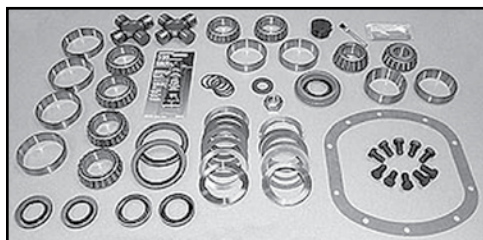

32015	Gear Install Kit, 80-82	\$79
32016	Gear Install Kit, 93-96	\$78
32017	Overhaul Kit, 80-82 W/Bolt-in Axle	\$145
32018	Overhaul Kit, 80-92 W/C-clip Axle	\$125
32019	Overhaul Kit, 93-96	\$124

RING AND PINIONS

All 1980-96 model Broncos and F150 pickups came equipped with a Dana 44 IFS (independent front suspension) front axle. They differ from many standard monobeam Dana 44's because they utilize a pinion gear that is located above the axle shaft centerline and require a ring and pinion with the tooth angle reversed. This is referred to as reverse spiral bevel or reverse rotation. Our quality Yukon Gear gear set can be installed as a performance enhancer, or as a simple stock replacement.

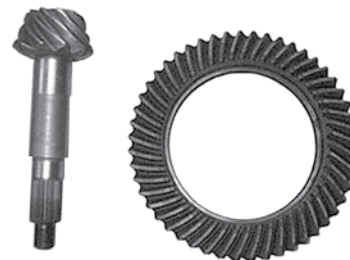
**YUKON GEAR.**

22060	3.54 Gear Ratio	\$239
22060A	3.73 Gear Ratio	\$204
22060B	4.09 Gear Ratio	\$310
22060C	4.56 Gear Ratio	\$226
22060D	4.88 Gear Ratio	\$226
22060E	5.13 Gear Ratio	\$226
22060F	5.38 Gear Ratio	\$226

USA STANDARD GEAR

22061	3.54 Gear Ratio	\$158
22061A	3.73 Gear Ratio	\$144
22061B	4.09 Gear Ratio	\$158
22061C	4.56 Gear Ratio	\$158
22061D	4.88 Gear Ratio	\$158
22061E	5.13 Gear Ratio	\$158
22061F	5.38 Gear Ratio	\$158

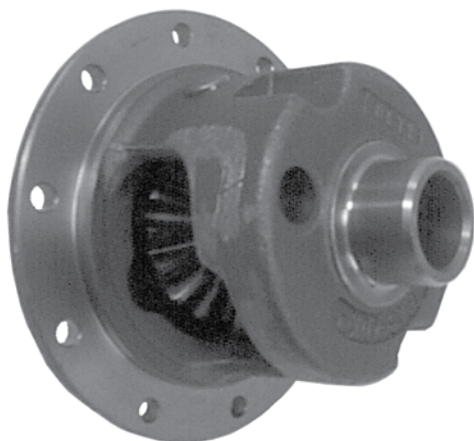
**NON-LOCKING DIFFERENTIALS**

Non-locking (open) differentials are what is found in most stock Dana 44 front ends. We carry quality OEM Dana/Spicer replacements for your broken or worn out unit.

12140	Complete Case 3.92/Down	\$139
12142	Complete Case 3.93/Up	\$139
12143	Case Only 3.92/Down	\$94
12145	Case Only 3.93/Up	\$89
12146	Internal Gear Kit	\$94
32021	Internal Gear Kit (use with c-clip axles)	\$119

TRAC-LOK LIMITED SLIP DIFFERENTIAL

The Spicer Trac-Lok differential provides much greater traction than regular (open) differentials by distributing power equally to both wheels in low traction situations. This is achieved by a set of spring loaded clutches inside the differential which lock it up under straight line driving conditions but will allow for some slipping to occur while driving around corners, where the outside tire must travel faster than the inside tire.

22090	Trac-Lok Case Only 3.92/Down	\$148
22092	Trac-Lok Case Only 3.93/Up	\$148
22094	Complete Trac-Lok 3.92/Down	\$299
22096	Complete Trac-Lok 3.93/Up	\$279
22098	Trac-Lok Internal Gear Kit	\$229

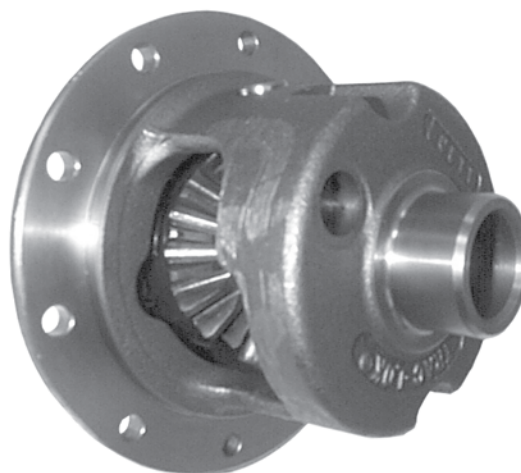



TRUE-TRAC LIMITED SLIP DIFFERENTIALS

Detroit truetrac was the first helical gear differential ever introduced into the automotive aftermarket. It remains the leading helical gear-type limited slip differential in the industry. Detroit Truetrac's proven helical gear design eliminates the need for wearable parts, resulting in maintenance free traction. Recognized not only for its durability but also its smooth and quiet operation.

22107	True-Trac 3.92/Down	\$459
22108	True-Trac 3.93/Up	\$459

DETROIT LOCKER® DIFFERENTIALS

The Detroit Locker® is different than other limited slip differentials because it is a true mechanical positive lock-up differential. No clutches to wear out. Designed for severe operating conditions. Because of its rugged mechanical design, driver may hear and feel "backlash" going from drive to coast and coast to drive as reversing torque flow resets the components.

22117	Detroit Locker 3.92/Down	\$579
22118	Detroit Locker 3.93/Up	\$599
22080	Yukon Grizzly Locker, 3.93/Up	\$599

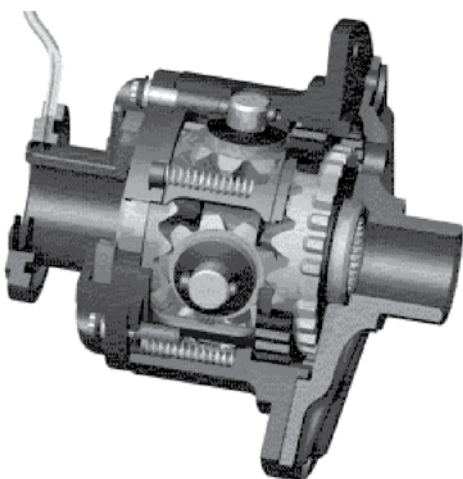
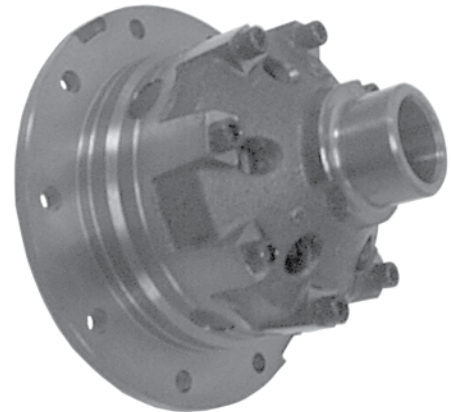

ZIP AIR LOCKER

The Zip Air Locker is an air operated driver controlled locking differential activated by pushing a dash mounted button. When engaged, an on-board air compressor sends air to the differential. This activates an internal locking mechanism locking both axles. Push the button again and the air is released returning the unit to a fully open standard differential.

21942	ARB Air Compressor Kit	\$323
11922	Yukon Zip Locker 3.93/Up	\$769

AXLE SHAFTS

Bolt-in, quality Dana/Spicer replacement axles for your stock vehicle.

32050	Inner Axle, RH (c-clip style)	\$98
32050A	Inner, RH (bolt-in style)	\$149
30251	Shaft/Slip Yoke Assembly (c-clip)	\$139
32053	Intermediate Shaft, RH	\$129
32054	Axle Assembly, RH, 80-96	\$175
32060	Inner Axle, LH	\$95
32061	Axle Assembly, LH	\$179
32067	Outer Axle, 80-96 (except 87)	\$84
32069	Outer Axle (87 only)	\$75
32052	RH Slip Yoke, 80-83	\$99
32052A	RH Slip Yoke, 84-96	\$99

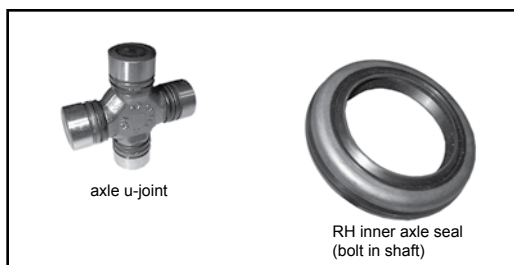
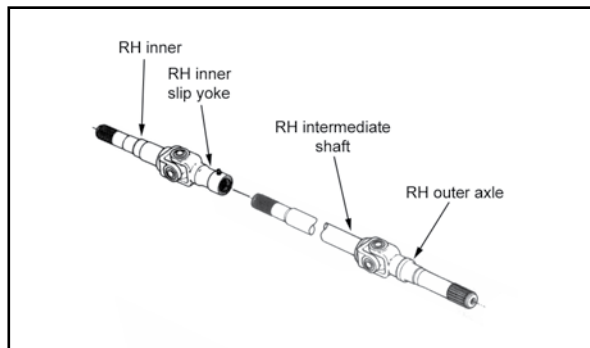
**U-JOINTS & MISCELLANEOUS**

32072	Axle Shaft U-Joint (Dana/Spicer)	\$33
32073	Inner Axle Seal, RH, 83-96 (c-clip style)	\$9
32074	Inner Axle Seal, RH, 80-82 (bolt-in style)	\$4
32075	Inner Axle Seal, LH	\$5

OUTER FRONT END KITS

Maintain/rebuild the outer wheel area of your front end with these convenient kits. **Rebuild kit includes:** hub & rotors, ball joints, spindles, wheel bearings & seals, spindle nuts & washers, outer axles, U-joints, and lockouts. **Maintenance kit includes:** ball joints, U-joints, spindle bearings & seals and wheel bearings & seals.

32079	Outer Wheel Rebuild Kit, 80-92 (both sides)	\$769
32079A	Maintenance Kit, 80-94 (both sides)	\$199

**BALL JOINTS**

Step up to the finest quality ball joint on the market. These Dana/Spicer ball joints are just like the factory Ford units. Sold in pairs (one upper and one lower). Includes attaching hardware.

32105	Ball Joints, 1980-96 Bronco/F150 (pair)	\$64
-------	---	------

SPINDLE AND RELATED

More Dana/Spicer parts to help get you back on the road.

32080	Spindle, 80-92½ Bronco/F-150	\$135
32082	Spindle, 87-88½ Bronco/F-150 (W/1 piece hub design)	\$120
32083	Spindle, 93-94 Bronco/F150 Non ABS Spindle	\$115
32084	Spindle, 94&96 W/ABS Bronco/F-150	\$124
32085	Spindle, 93 W/ABS Bronco/F-150	\$369
32086	80-92 Spindle Stud	\$4
32086A	93-96 Spindle Stud	\$4
32087	Spindle Bearing Kit 80-92 Bronco/F-150	\$10
32087A	Spindle Bearing Kit 93-96 Bronco/F-150	\$12
32089	94-96 Front ABS Sensor	\$69
32092	Spindle Nut & Washer Kit (does one spindle)	\$10

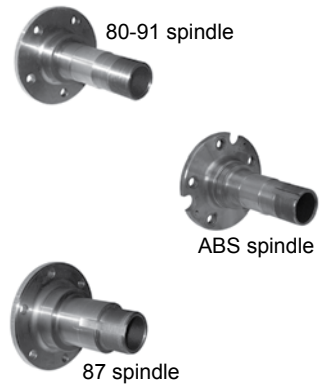

HUB AND ROTOR ASSEMBLY

These hub and rotor assemblies are direct bolt on replacements for your original unit. Each comes factory assembled with new hub, rotor, wheel studs, and wheel bearing races installed. Just add one of our Hub & Rotor install kits (includes hub seal and Timken wheel bearings) to complete the job.

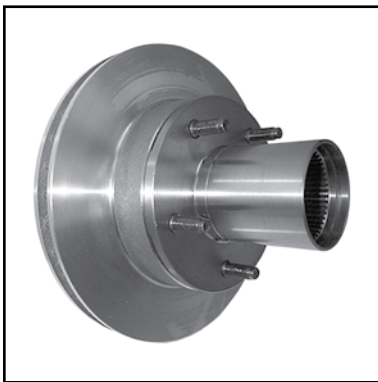

32092A	Bronco/F-150, 80-86	\$109
32093	Bronco/F-150, 1987½-92	\$109
32093A	Bronco/F-150, 1993	\$99
32093B	Bronco, 94-5/95	\$99
32093C	Bronco, 5/95-96, W/4 Whl. ABS	\$99
32092K	Hub & Rotor Install Kit, Bronco/F-150, 80-95	\$36
32093K	Hub & Rotor Install Kit, Bronco/F-150, 95-96	\$36
32093D	Bronco/F150, 5/95-96	\$99
32093E	F150, 1994-4/95	\$99

HUBS AND RELATED

32094	Hub 80-86/88-92 Bronco/F150	\$79
32095	Hub, 93-4/95 Bronco, 94 F150	\$79
32098	Hub Seal 80-86, 88-93	\$4
32090	Inner Wheel Bearing W/Race, Timken (exc 1987)	\$15
32091	Outer Wheel Bearing W/Race, Timken (exc 1987)	\$14
32099	2 pc. Hub Seal, 95-96	\$22
32015A	5/95-96 Bronco, 95-96 F150 4X4	\$79

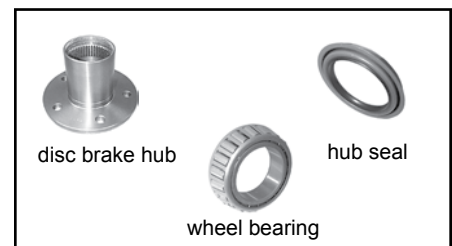

MILE MARKER HUBS

When it's time to replace your hubs, choose from these superior quality hubs. Each is built to exacting standards, and with improvements over the latest patents. You'll count on your MileMarker Hub, as millions have, for years of trouble free service. The Stainless supreme hubs feature a full stainless jacket around the cap for corrosion resistance. The extreme hubs feature solid stainless steel cap for superior corrosion resistance and the ultimate in strength.



32130	MM Stainless Supreme Hubs	\$69
32132	MM Manual Conversion Kit	\$89
12243RK	Lock-Out Service Kit	\$14

WARN PREMIUM LOCKOUTS

The Warn Premium Hub is a no-compromise hub designed for the hardcore off-roader or truck owner who will accept nothing less than the industry standard in performance.

32125	Warn Premium Lockouts	\$95
32126	Warn Premium Lockout Conversion Kit	\$119
32127	Warn Standard Lockouts	\$75
32127K	Warn Standard Lockout Conversion Kit	\$95
12242SK	Warn Lock-Out Service Kit	\$26

**DUST SHIELDS**

32116	Bronco/F150, RH, 80-93	\$80
32117	Bronco/F150, LH, 80-93	\$80
32118	Bronco/F150, RH, 94-96	\$105
32119	Bronco/F150, LH, 94-96	\$72

PINION FLANGE & RELATED

22122	Pinion Flange, 1310 Series U-Joint	\$58
22124	Pinion Flange, 1330 Series U-Joint	\$58
22126	Pinion Flange, 1350 Series U-Joint	\$129
22119	Pinion Seal	\$5
22121	Pinion Nut & Washer	\$4

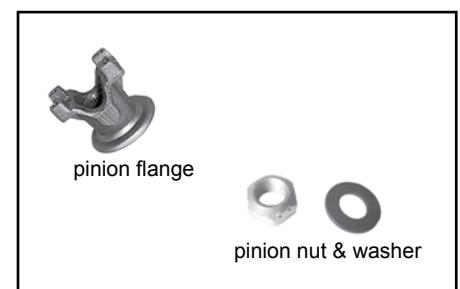

Dana 44 IFS front

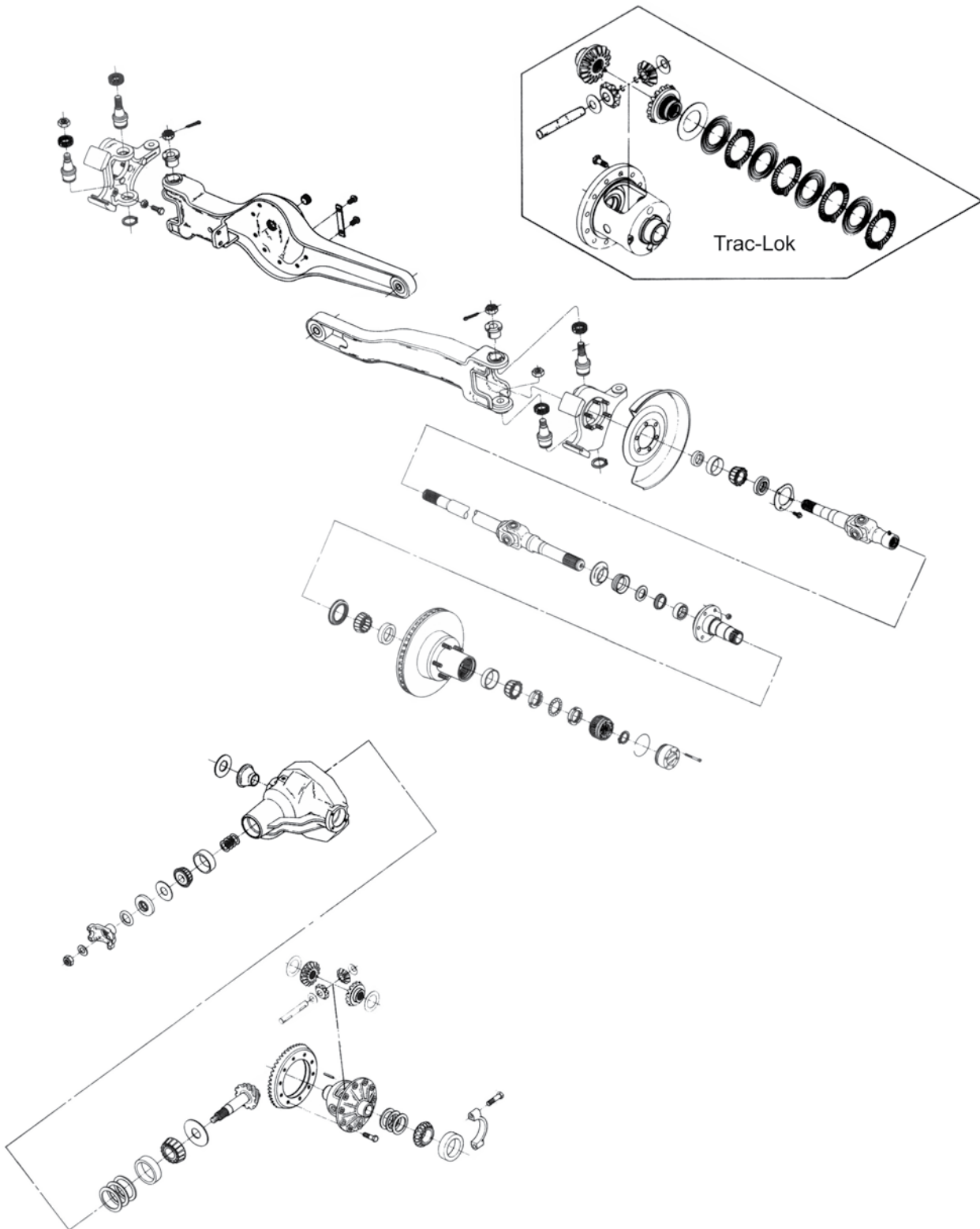

DANA 50 FRONT

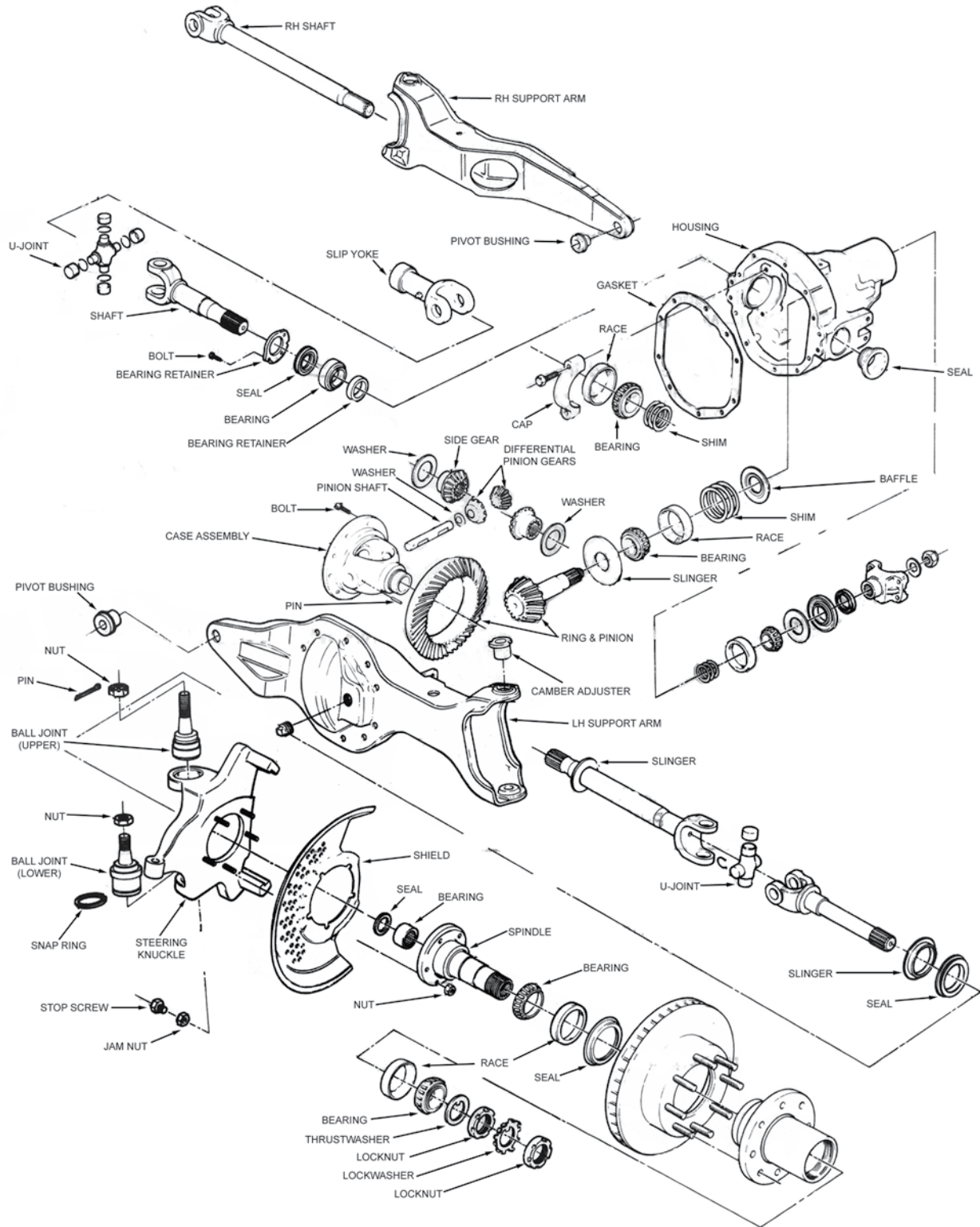

RING & PINION

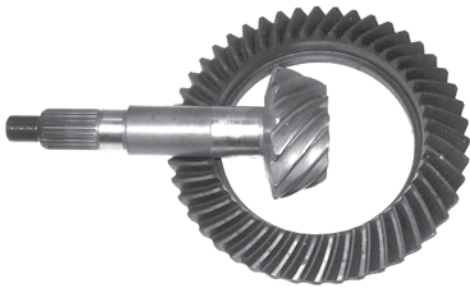

31715	D50 Ring & Pinion 3.54 Ratio	\$199
31715A	D50 Ring & Pinion 3.73 Ratio	\$305
31715B	D50 Ring & Pinion 4.10 Ratio	\$303
31715C	D50 Ring & Pinion 4.30 Ratio	\$226
31715D	D50 Ring & Pinion 4.56 Ratio	\$226
31715E	D50 Ring & Pinion 4.88 Ratio	\$226
31715F	D50 Ring & Pinion 5.13 Ratio	\$286
31715G	D50 Ring & Pinion 5.38 Ratio	\$226

LOCKOUT HUBS

31700	Dana 50 Lockouts, Milemarker Stainless	\$139
11702	Dana 50 Lockouts, Warn Standard	\$239



BEARING KITS

Gear install kit includes: Pinion bearings, pinion shims, pinion seal, lock nut and cover gasket. **Overhaul kit includes:** All above parts and adds carrier bearings and shims.

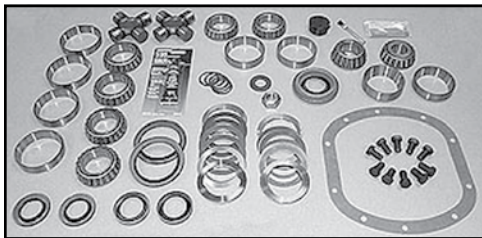

31790	Dana 50 Gear Installation Kit	\$84
31791	Dana 50 Overhaul Kit	\$99
31792	Dana 50 Shim Kit	\$19

OPEN DIFFERENTIAL

31709	Open Case, Bare	\$303
31709A	Open Case Internal Kit	\$153

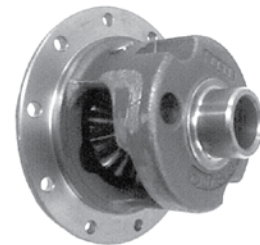

LIMITED SLIP DIFFERENTIAL

31711	Dana 50 Lock-Right	\$385
31712	Dana 50 Powr -Lok	\$572
31714	Yukon Grizzly Locker	\$553

U-JOINT & AXLE

31770	Axle U-Joint	\$30
31762	RH Intermediate Axle 1990/Up	\$109
31768	Outer Axle	\$199
31755	LH Inner Axle Seal	\$5
31756	RH Inner Axle Seal	\$6

**BALL JOINTS**

31702L	Ball Joint, Lower	\$59
--------	-------------------	------

SPINDLE

31730	80-97 Dana 50 Spindle	\$149
31730A	D50 Spindle Stud, Each	\$4
31731	Dana 50 Spindle Repair Kit	\$12
31733	Dana 50 Spindle Nuts & Washer Kit	\$19
31739	D50 Brake Dust Shield, LH	\$70
31739R	D50 Brake Dust Shield, RH	\$70

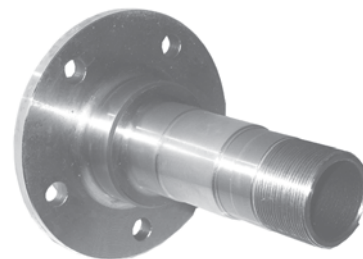
**PINION YOKE**

31725	1330 Series Pinion Yoke	\$48
31726	1350 Series Pinion Yoke	\$96

WHEEL BEARINGS & SEALS

31735	Dana 50 Inner Wheel Brg. W/Race	\$26
31736	Dana 50 Outer Wheel Brg. W/Race	\$16
31737	Dana 50 Hub Seal	\$7

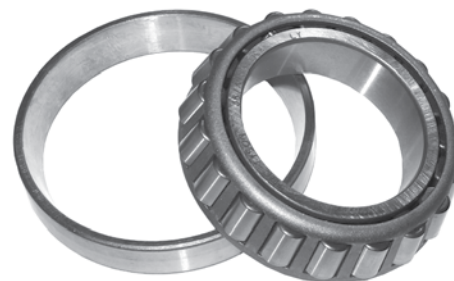

Inner wheel bearing with race

DANA 60 FRONT

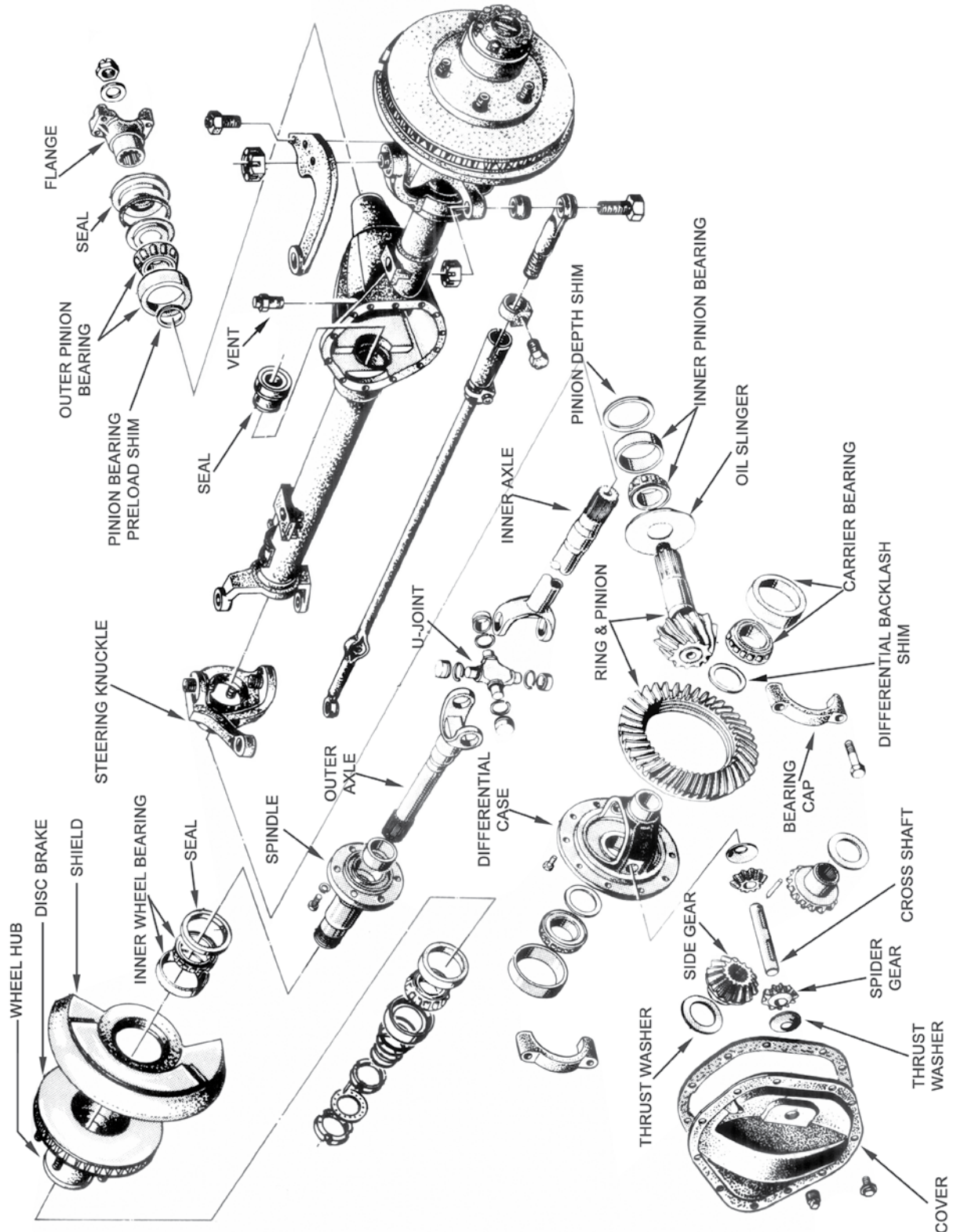



SELECTRO/MILEMARKER LOCK-OUT HUBS

When it's time to replace your hubs, choose these superior Selectro/Milemarker hubs. Each is built to exacting standards, and with improvements over the latest patents. You'll count on your Selectro/MileMarker Hub, as millions have, for years of trouble free service.

11700	Milemarker Lock-out Hub, Dana 60	\$148
11701	Milemarker 35spl, Stainless Lock-outs, Dana 60	\$159
11701S	Selectro Lock-out Hub, Dana 60	\$295
11702	Warn Premium 35spl Hubs, Dana 60	\$259
11702A	Warn Premium 30spl Hubs, Dana 60	\$239
11702B	Warn Std 30spl Hubs, Dana 60	\$209

SPINDLES & HUBS

11704	Spindle, Dana 60, 78-91½	\$125
11706	Spindle, Dana 60, 92-98	\$149
11704N	Spindle Nuts & Washers, Dana 60	\$19
11705	Spindle Bearing & Seal Kit	\$15
11707IN	Inner Wheel Brg Kit	\$26
11707OUT	Outer Wheel Brg Kit	\$16



Dana 60 spindle



8 lug hub

STOCK ROTORS

11714	Rotor, Dana 60, 78-94	\$45
11715	Rotor, Dana 60, 95-98	\$45
11716	Rotor, Dana 60, 99-3/14/99	\$65
11717	Rotor, Dana 60 3/15/99-2000	\$55

EXTREME PERFORMANCE ROTORS

11714XL	Cross Drilled Rotor, LH 78-94	\$80
11714XR	Cross Drilled Rotor, RH 78-94	\$80
11715XL	Cross Drilled Rotor, LH 95-98	\$90
11715XR	Cross Drilled Rotor, RH 95-98	\$90



AXLE SHAFTS

11785	D60 Outer Axle 77-84	\$115
11788	D60 Outer Axle 85-88	\$139
11791	D60 Outer Axle 88½-98	\$99
11782	D60 Inner Axle LH 78-79	\$179
11783	D60 Inner Axle RH 78-79	\$94
11786	D60 Inner Axle RH 85-88	\$199
11787	D60 Inner Axle LH 85-88	\$139
11789	D60 Inner Axle LH 88½-98	\$189
11790	D60 Inner Axle RH 88½-98	\$199
11795	Moser Max Axles (set of 4)	\$849





CHROME MOLY AXLE SHAFTS

11785A	Chrome Moly Outer 35 Spl, 77-88	\$119
11785B	Chrome Moly Outer 35 Spl, 88½-98	\$90
11786CM	85-88 Chrome Moly RH Inner	\$168
11787CM	85-88 Chrome Moly LH Inner	\$168
11789CM	88½-98 Chrome Moly LH Inner	\$168
11790CM	88½-98 Chrome Moly RH Inner	\$168

AXLE U-JOINT

11793	Dana 60 U-joint (greasable)	\$65
11793N	Dana 60 Axle U-Joint (non-greasable)	\$52



king pin repair kit



ball joint kit

BALL JOINT/KING PIN REPAIR

11720	King Pin Repair Kit	\$70
11725	OEM Ball Joint Kit	\$75

DANA 60 FRONT RING & PINION

Because the pinion gear is located above the axle centerline, front Dana 60's require a reverse spiral bevel or "reverse rotation" gear set. The letter "T" after a number indicates a "thick" gear set (used when changing to a higher numerical ratio while retaining the 4.10/down differential).

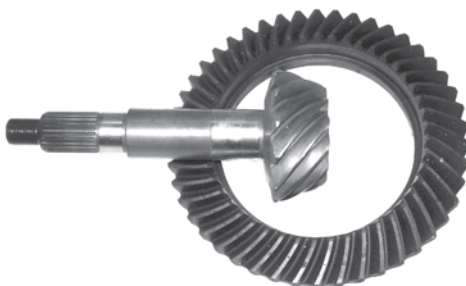

11741	3.54 Ratio	\$289
11741A	4.10 Ratio	\$239
11741B	4.56 Ratio	\$239
11741C	4.56T Ratio (thick gear)	\$239
11741E	4.88 Ratio	\$239
11741F	5.13 Ratio	\$239
11741G	5.38 Ratio	\$239

DIFFERENTIALS

11751	Detroit Locker 4.10/Down	\$618
11751A	Detroit Locker 4.56/Up	\$618
11756	Powr-Lok 4.10/Down	\$662
11756A	Powr-Lok 4.56/Up	\$662
11757	Trac-Lok 4.10/Down	\$471
11757A	Trac-Lok 4.56/Up	\$570

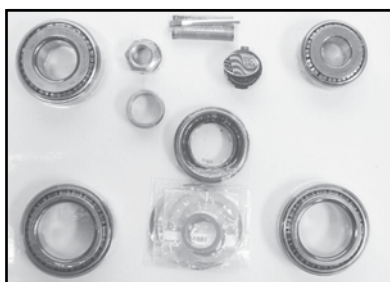
**BEARING KITS**

11770	Master Overhaul Kit, D60	\$139
11773	Bearing & Seal Kit, D60	\$89
11772	Seal & Shim Kit	\$59

Selecting the proper gear ratio.

Calculating the correct gear ratio for you application is easy when applying the following variables. (1)Tire Size (2)Gear Ratio (3)MPH (4)RPM. The formula is as follows.

M.P.H. X Gear Ratio

$$\text{Tire Diameter} \quad \times \quad 336 = \text{RPM}$$

The chart below has been assembled to assist you in your gear selection. It shows RPM calculations (based on a cruise speed of 55 MPH) for various combinations of gear ratio and tire diameter.

The acceptable RPM range at cruise speed is 2000-3000, which is represented by the entire shaded area below. The optimum RPM range is 2300-2600 (represented by the lighter shaded area). When trying to improve mileage choose a ratio in the shaded area above the lighter shade, when trying to improve power choose a ratio in the shaded area below the lighter shade.

Gear Ratio	Tire Diameter																
	24	25	26	27	28	29	30	31	32	33	34	35	36	38	40	42	44
3.08	2372	2277	2189	2108	2033	1963	1897	1836	1779	1725	1674	1626	1581	1498	1423	1355	1294
3.54	2726	2617	2516	2423	2336	2256	2181	2110	2044	1982	1924	1869	1817	1772	1635	1558	1487
3.73	2872	2757	2651	2553	2462	2377	2298	2224	2154	2089	2027	1969	1915	1814	1723	1641	1567
3.90	3003	2883	2772	2669	2574	2485	2402	2325	2252	2184	2120	2059	2002	1897	1802	1716	1638
4.10	3157	3031	2914	2806	2706	2613	2526	2444	2368	2296	2228	2165	2105	1994	1894	1804	1722
4.56	3511	3371	3291	3121	3010	2906	2809	2718	2633	2554	2478	2408	2341	2218	2107	2006	1915
4.88	3758	3607	3469	3340	3221	3110	3006	2909	2818	2733	2652	2577	2505	2373	2255	2147	2050
5.38	4143	3977	3824	3682	3551	3428	3314	3207	3107	3013	2924	2841	2762	2616	2486	2367	2260
5.71	4397	4221	4058	3908	3769	3639	3517	3404	3298	3198	3104	3015	2931	2777	2638	2512	2398
6.17	4751	4561	4385	4223	4072	3932	3801	3678	3563	3455	3354	3258	3167	3001	2851	2715	2591
7.17	5521	5300	5096	4907	4732	4569	4417	4274	4141	4015	3897	3786	3681	3487	3313	3155	3011

SPEEDOMETER GEARS

One of the biggest frustrations for Bronco/Truck owners is trying to calculate which speedometer gear to use after modifying your rig with larger tires and differential gears or maybe both. Those frustrations are over when you use this speedometer gear equation (Mom & Dad were right, you do use 9th grade math in the real world). All you need is some basic info about your ride. Suppose you just replaced your old 29" tires with a new set of 33's and your current speedo gear has 19 teeth. Just plug your numbers into the following equation:

$$\frac{\text{Old tire dia. X Old speedo gear}}{\text{New tire dia.}} = \text{New speedo gear}$$

$$\frac{29 \times 19}{33} = 16.69 \text{ (17 tooth)}$$

There is a similar equation for use when calculating speedo gear changes after you change differential gear ratios it is as follows:

$$\frac{\text{Speedo gear teeth}}{\text{Old gear ratio}} \times \text{New gear ratio} = \text{New speedo gear}$$

Still using the first scenario lets suppose that sometime after you upgraded your tires you decide to change gears in your front and rear differentials with a set of 4.10's. The equation would look like this:

$$\frac{17}{3.55} \times 4.10 = 19.6 \text{ (20 tooth)}$$

Based on information by Chris Bradley as published by Bronco Driver magazine

REPLACEMENT SPEEDO GEARS

37192A	Driven Gear 16T, (wine)	\$6
37192B	Driven Gear 17T, (white)	\$6
37192C	Driven Gear 18T, (yellow)	\$6
37192D	Driven Gear 19T, (natural)	\$6
37192E	Driven Gear 20T, (black)	\$6
37192F	Driven Gear 21T, (red)	\$6
37192x	Speedo Driven Gear Clip	\$1



SPEEDOMETER CABLES

31680	80-86 W/O Cruise	\$24	31684	80-85 W/Ratio Adapter	\$12
31681	80-85 Upper	\$10	31685	86-91 W/Cruise	\$14
31682	80-85 W/O Ratio Adapter, Auto	\$16	31686	87-91 W/O Cruise	\$19
31683	81-85 W/O Ratio Adapter, Manual	\$16	31687	92-96 Bronco, Speedo Cable	\$17

9" TRAC-LOK EXPLODED VIEW

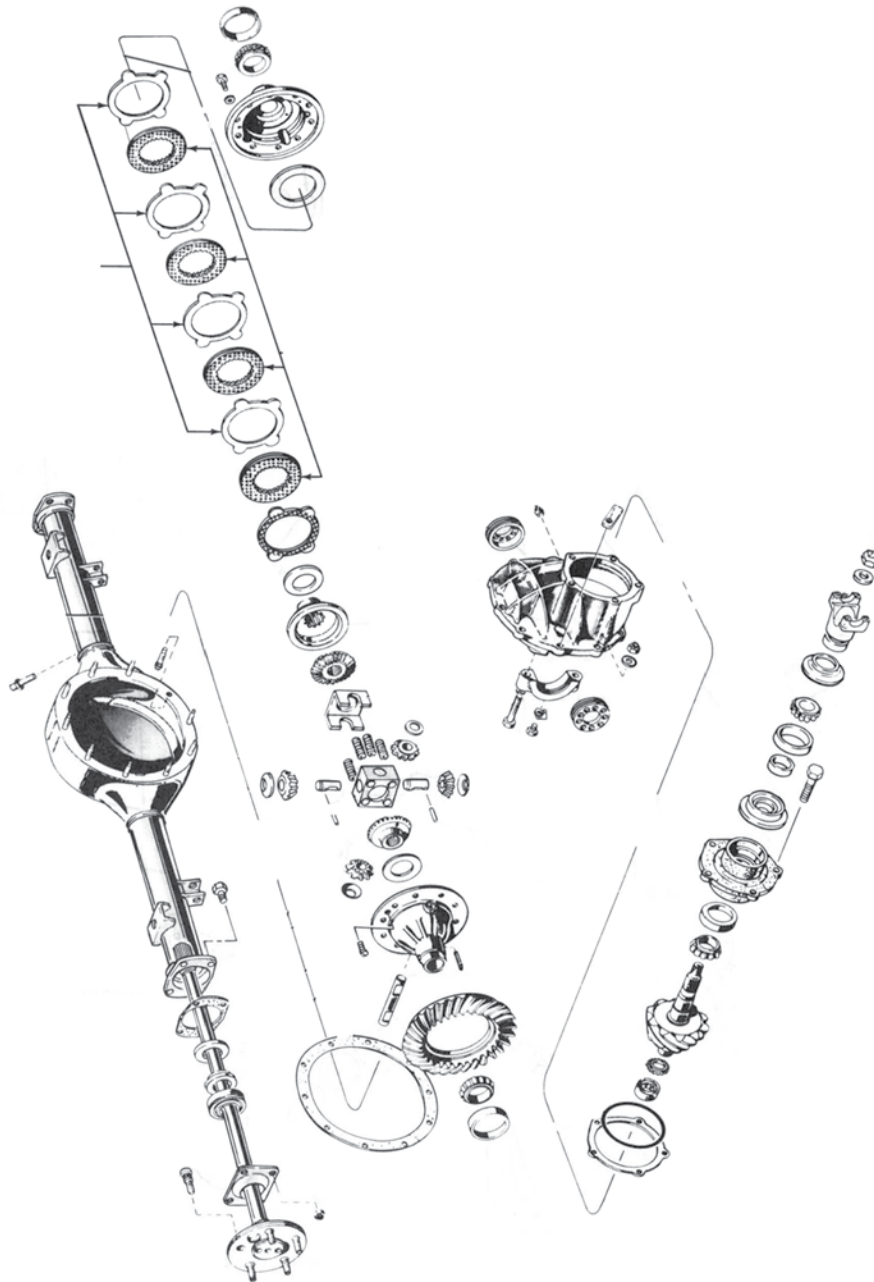

9" REAR ENDS

REMANUFACTURED THIRD MEMBERS

These third members have been completely remanufactured using all new components except for the housing itself (new high strength housings are available at extra cost). Ready to bolt in (pinion yoke sold separately). Please specify desired gear ratio when ordering.

22210	Third Member, 31 Spline, Open	\$819
22211	Third Member, 31 Spline, Trac-Lok	\$849
22212	Third Member, 31 Spline, Detroit Locker	\$1149
22213	Third Member, 35 Spline, Detroit Locker*	\$1349
22280	Pinion Yoke (1310 series)	\$72
22282	Pinion Yoke (1330 series)	\$49
22284	Pinion Yoke (1350 series)	\$95

*equipped with high strength housing and Daytona pinion support.

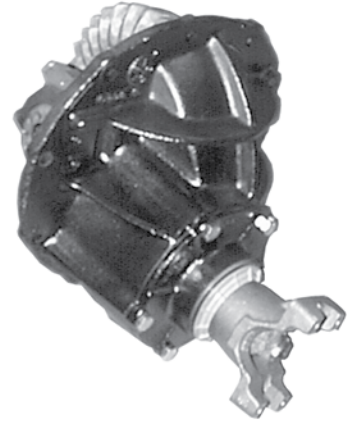

CASE AND RELATED

22204	9" Nodular Iron Case	\$249
22205	Daytona Pinion Support	\$79
22218	Housing Gasket	\$5
22219	O-Ring Seal	\$1

YUKON GEAR® RING AND PINIONS

Big lift kit and even bigger tires slowing you down? Upgrade your rear end gear ratio with one of these high quality Yukon Gear® gear sets. These gear sets are designed to run quieter and last longer than any other gears on the market. Manufactured to our high standards Yukon gears are the premium choice for off-road, or recreational, 4 wheel drive enthusiasts. Free shipping to the continental US.

22221	3.10 Ratio Yukon Gear	\$279
22221A	3.33 Ratio Yukon Gear	\$279
22221B	3.50 Ratio Yukon Gear	\$279
22221C	3.70 Ratio Yukon Gear	\$279
22221E	4.11 Ratio Yukon Gear	\$279
22221G	4.56 Ratio Yukon Gear	\$279
22221H	4.88 Ratio Yukon Gear	\$245
22221J	5.13 Ratio Yukon Gear	\$279
22221K	5.43 Ratio Yukon Gear	\$219
22221L	5.83 Ratio Yukon Gear	\$219

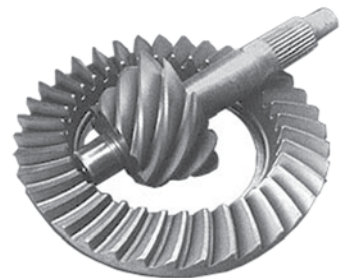

CLUTCH TYPE DIFFERENTIALS

Looking to upgrade your regular open differential. The Trac-Loc® is a locking type differential that uses clutches to transfer power to both rear wheels.

22240	31 Spline Trac-Lok	\$297
22239	Yukon Dura Grip, 31 Spline	\$399

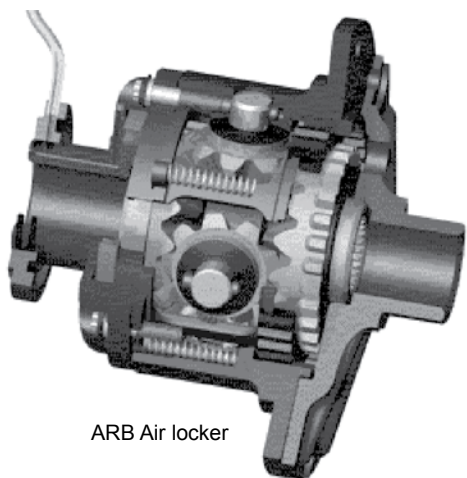

ARB Air locker

LOCKING DIFFERENTIALS

The Detroit Locker® achieves positive locking by using a rugged mechanical design for 100% lock-up during straight line driving, but still allows for cornering without damaging the differential or axle.

22230	Detroit Locker, 31 Spline	\$525
22231	Detroit Locker, 35 Spline	\$549
22360	Yukon Grizzly Locker, 31 Spline	\$485
22364	Yukon Grizzly Locker, 35 Spline	\$500
22255A	True-Trac, 31 Spline	\$491

BEARING KITS

Choose from three different bearing kits. **The gear install kit includes:** Pinion bearings, pinion seal, shims, crush sleeve, lock-nut and differential gasket. **Overhaul kit** adds pilot bearing and carrier bearings. **Master overhaul kit includes:** Overhaul kit plus axle bearings and seals

22274	Gear Install Kit	\$64
22273	9" Seal & Shim Kit	\$24
22276	Overhaul Kit	\$85
22278	Master Overhaul Kit	\$139
22270	Carrier Bearings (pair)	\$18
22272	Pilot Bearing	\$16

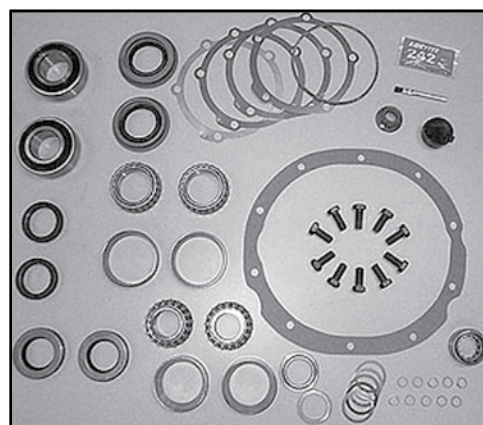



INTERNAL GEAR KIT

Replace the broken gears in your differential with our internal gear kits. **Kit includes:** 2 spider gears, 2 side axle gears, 2 spider gear washers, 2 side gear washers, and cross shaft.

22238G	Internal Gear Kit, Open Differential	\$120
22241	Internal Gear Kit (Trac-Lok)	\$135

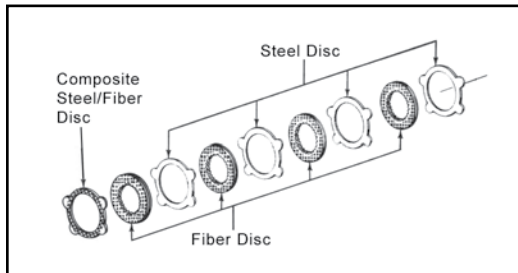

TRAC-LOK PARTS

22242	Trac-Lok Clutch Kit	\$54
22241B	Trac-Lok Block	\$25
22241BC	Trac-Lok Block Cover	\$10
22241S	Trac-Lok Spring	\$4

MORE TRAC-LOK PARTS

22349	Trac-Lok Clutch Hub (31 spline)	\$45
22258	Spider Gear	\$13
22260	Spider Gear Washer	\$1
22262	Cross Shaft (long)	\$16
22264	Cross Shaft (short)	\$10
22340	Axle Gear RH Or LH, Open	\$35
22349	Clutch Hub Gear	\$45
22346	Axle Gear LH Trac-Lok	\$45
22350	Axle Gear Thrust Washer	\$2

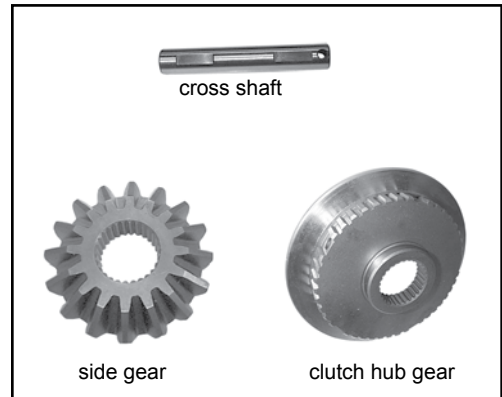

YUKON REPLACEMENT AXLES FOR 9" REAR

These stock replacement axle shafts are manufactured from a custom alloy which yields a shaft that is 20%-30% stronger than the stock axle. (Wheel bearing and retainer plate sold separately). **Axle kit includes:** Both axles, retainer plates, wheel bearings with seals and studs



22300	RH Axle, 80-86 Bronco, 80-86 F150	\$79
22301	LH Axle, 80-86 Bronco, 80-86 F150	\$79
22302	Axle Kit	\$215
22303	Axle Kit W/Timken Bearings	\$225

MOSER ULTIMATE 35 SPLINE AXLES

Moser ultimate 35 spline axles are forged from premium quality alloy steel. Induction heat treated to optimize torsional strength and 100% magnafluxed. This process gives the axle the strength of a "race only" axle while being ideal for street use as well. Shipped completely loaded and ready to install.

22307 Ultimate 35 Spline Axles (pair) \$450



wheel bearing & seal

WHEEL BEARINGS AND RELATED

22311	Wheel Bearing and Seal, 80-86 Bronco, PU	\$30
22311T	Wheel Bearing & Seal, 80-86 Bronco, PU (Timken)	\$39
32236	Wheel Bearing Retainer Plate 80-86 Bronco, PU	\$10
22316	Retainer Plate Stud 3/8" Dia.	\$3
22318	9" Wheel Stud	\$3

PINION FLANGE AND RELATED

22280	Pinion Flange (1310 series)	\$72
22282	Pinion Flange (1330 Series)	\$49
22284	Pinion Flange (1350 Series)	\$95
22290	Pinion Seal	\$4
32245	85-86 Pinion Seal	\$4
22292	Pinion Pre-Load Crush Sleeve	\$4
22294	Pinon Nut	\$4



pinion flange



pinion nut



crush sleeve



pinion seal



SPIDER
FROM PURPLE CRANIUM PRODUCTS

The ultimate in differential protection from Purple Cranium Products. These Spider Rock Guards combine attractive good looks with superior protection. Gray powder coat finish. Stainless mounting hardware included.

20838 Spider Rock Guard Ford 9" \$165

8.8" REAR END

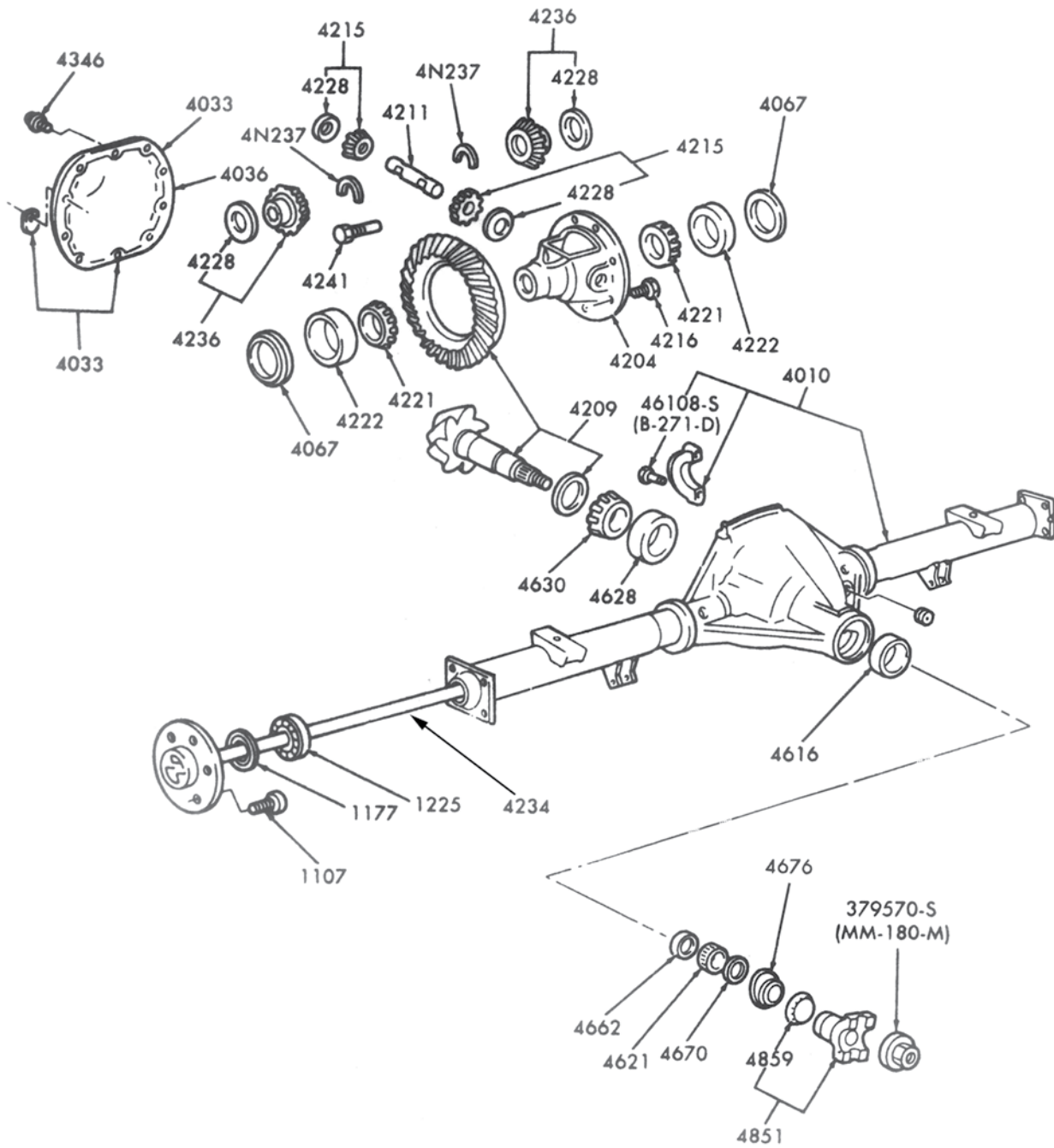

©Ford Motor Co.

RING AND PINIONS FOR 8.8" REAR

Big lift kit and even bigger tires slowing you down? Upgrade your rear end gear ratio with one of these high quality Yukon Gear® gear sets.

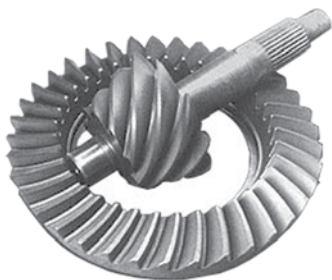

32310	Ring & Pinion, 3.08 Gear Ratio	\$168
32310A	Ring & Pinion, 3.55 Gear Ratio	\$224
32310B	Ring & Pinion, 3.73 Gear Ratio	\$224
32310C	Ring & Pinion, 4.11 Gear Ratio	\$224
32310D	Ring & Pinion, 4.56 Gear Ratio	\$224
32310E	Ring & Pinion, 4.88 Gear Ratio	\$224
32310F	Ring & Pinion, 5.13 Gear Ratio	\$224
32310G	Ring & Pinion, 5.71 Gear Ratio	\$265
32310H	Ring & Pinion, 6.14 Gear Ratio	\$265

8.8" REBUILD KITS

Everything you need to completely rebuild the center section of your 8.8" rear end. Consisting of all new parts our rebuild kits include: New Yukon Gear® gear set, new differential carrier and all bearings, seals and gaskets required to complete the job (axles and axle bearings sold separately). Many gear ratios to choose from as well as many different limited slip options including Detroit Locker and Eaton. Please call for pricing and availability for kit configurations not listed below.

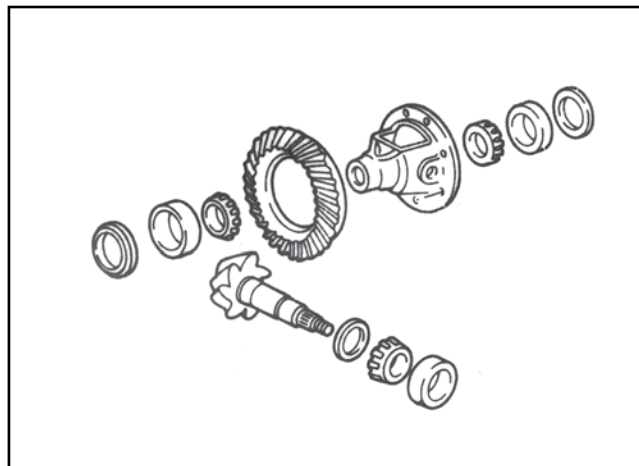

32380	Rebuild Kit, 3.55 Gear, Open Differential	\$519
32380A	Rebuild Kit, 3.55 Gear, DuraGrip Differential	\$589
32381	Rebuild Kit, 3.73 Gear, Open Differential	\$519
32381A	Rebuild Kit, 3.73 Gear, DuraGrip Differential	\$589
32382	Rebuild Kit, 4.10 Gear, Open Differential	\$519
32382A	Rebuild Kit, 4.10 Gear, DuraGrip Differential	\$589

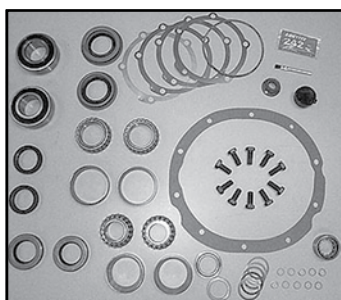
**BEARING KITS**

Choose from two different bearing kits. **The gear install kit includes:** Pinion bearings, pinion seal, pinion shims, crush sleeve, locknut and differential gasket. **Overhaul kit** adds carrier bearings.

32316	Gear Install Kit	\$48
32318	Overhaul Kit	\$89

8.8" DIFFERENTIALS

32320	Complete Open Differential	\$235
32320A	Internal Gear Kit (open diff)	\$155
32324	Complete Trac Lok Differential	\$359
32325	8.8" Eaton Posi 31 spline	\$445
32328	8.8" ARB Air Locker 31 Spline	\$775
32321	83-86 Detroit Locker	\$579
32321A	87-Newer Detroit Locker	\$595
32335	Yukon DuraGrip	\$319



Trac-Lok

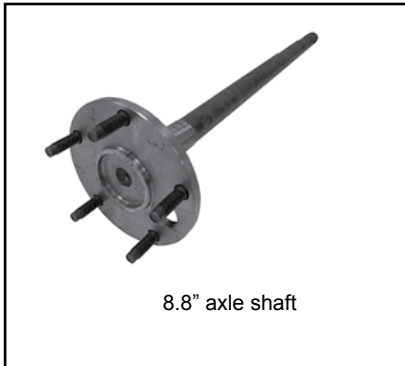

8.8" axle shaft

YUKON REPLACEMENT AXLES FOR 8.8" REAR

32360A	Axle Shaft, RH 1983-86 Bronco/F-150	\$75
32660B	Axle Shaft, LH 1983-86 Bronco/F-150	\$75
32362A	Axle Shaft, RH 1987-96 Bronco/F-150	\$75
32362B	Axle Shaft, LH 1987-96 Bronco/F-150	\$75
32368	Axle Bearing & Seal	\$15
32369	Wheel Stud	\$2

COMPLETE AXLE SETS

These complete axle sets include a pair of left and right axles, axle bearings, seals and wheel studs.

32360	Complete Axle Set 83-86	\$185
32362	Complete Axle Set 87-96	\$179
32367	Complete Moser Axle Set	\$299



MISCELLANEOUS

32345	8.8" Rear Cover	\$29
32345A	8.8" HD Aluminum Cover	\$175
32345C	Chrome Rear Cover	\$32
32345G	Rear Cover Gasket	\$5
32359	Pinion Nut	\$4
32355	Pinion Flange, 1983-89 Bronco	\$82
32356	Pinion Flange, 1990-96 Bronco	\$45
32357	Pinion Seal	\$4
32358	Pinion Pre-load Crush Sleeve	\$3
32390	ABS Speed Sensor	\$19



pinion flange



pinion nut



crush sleeve



flange 83-96 Bronco

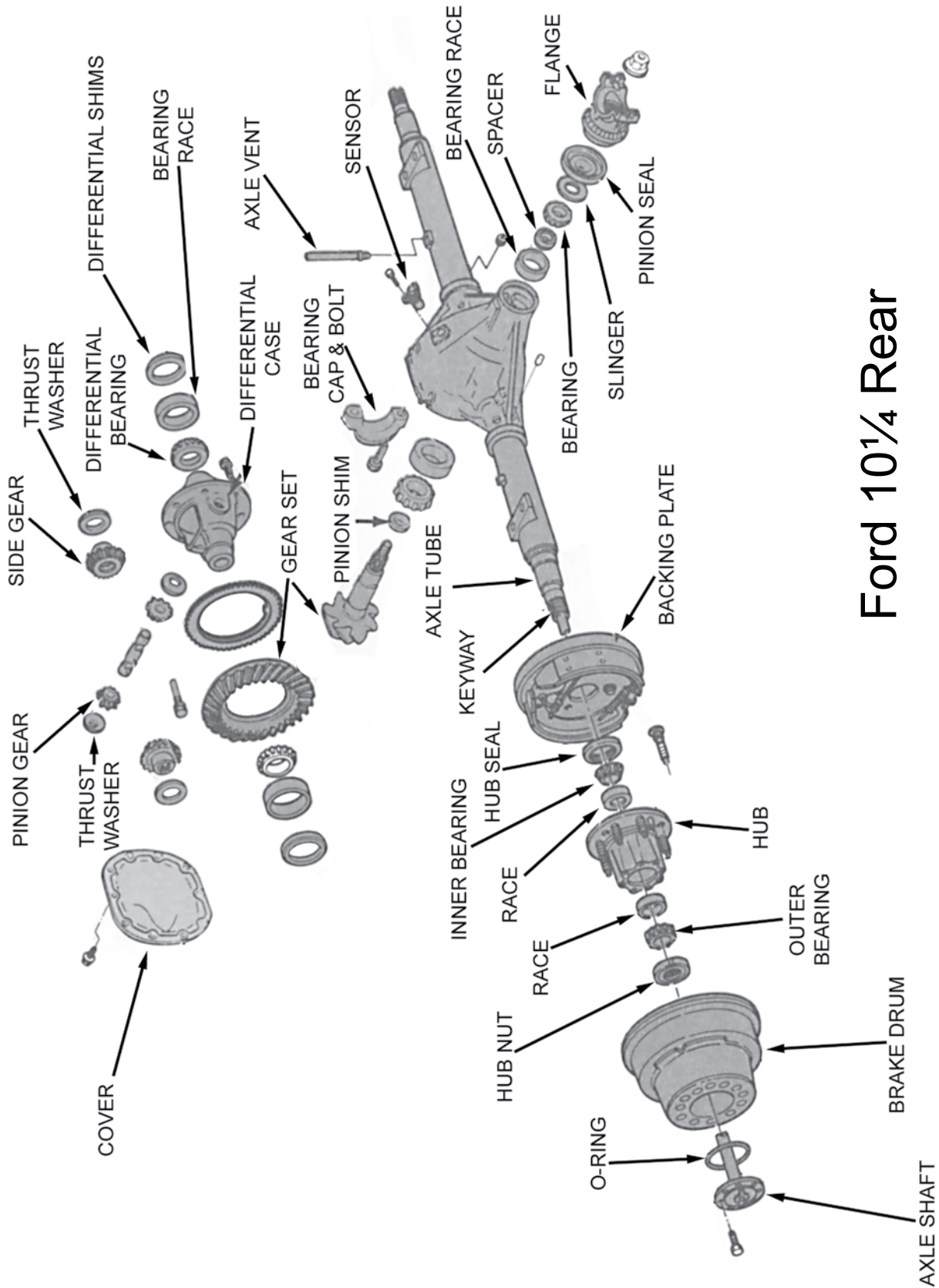

Ford 10 1/4 Rear

10¹/₄" REAR END

RING & PINION

Made from 8620 triple alloy steel(chrome-nickel-moly) these **Yukon Gears** meet our high standards for quality, long life and smooth quiet operation. The premium choice for professional and recreational 4 wheel drive enthusiasts.

For the budget conscious wheelers: Try one of our economically priced **USA Standard** gears. Enjoy Free Shipping on any Yukon or USA Standard gear.

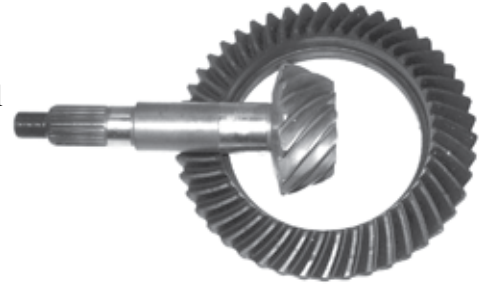

YUKON GEAR*

31910	3.55 Ratio	\$283
31910A	3.73 Ratio	\$224
31910B	4.10 Ratio	\$221
31910C	4.30 Ratio	\$276
31910D	4.56 Ratio	\$284
31910E	4.88 Ratio	\$239
31910F	5.13 Ratio	\$309
31910G	5.38 Ratio	\$313

USA STANDARD GEAR*

31911	3.55 Ratio	\$195
31911B	4.10 Ratio	\$195
31911C	4.30 Ratio	\$176
31911D	4.56 Ratio	\$187
31911B	4.88 Ratio	\$191

*All of the listed gears are for use in 1993 and newer applications. Use in 1985-93 models requires the use of "short style" Yoke.



BEARING KITS.

Master rebuild kit includes: all required bearings, seals, shims and crush sleeve. **Gear install kit includes:** pinion bearings & pinion shims, pinion seal, crush sleeve and new nut.

31900	10 ¹ / ₄ Rear Master Rebuild Kit	\$149
31918	10 ¹ / ₄ Rear Gear Install Kit	\$149
31909	Complete Shim Set	\$14

DIFFERENTIALS

31905A	10 ¹ / ₄ Rear Open (case only)	\$155
31905B	10 ¹ / ₄ Rear Open Spider Gear Set	\$198
31901	Trak-Lok Case (Dana design)	\$525
31901A	Trak-Lok Case (OEM design)	\$221
31901B	Clutch Disc Set (Dana design)	\$189
31901C	Clutch Disc Set (OEM)	\$95
31940	Auburn Posi	\$749
31941	Eaton Posi	\$625
31943	ARB Air Locker (full float only)	\$798
31945	Detroit Locker	\$649



AXLE SHAFTS

31920	85-97 F250 Semi-Float (33½")	\$199
31921	85-88 F350 Full Float (35½")	\$197
31925	Bearing & Seal (semi-float)	\$31
31926	Bearing & Seal (full float)	\$57
31926A	Seal Only (full float)	\$13

COVERS AND DIFFERENTIAL PROTECTION

31980	Chrome Cover	\$55
31981	Gasket	\$3
31982	OEM Cover	\$49
31983	Aluminum cover	\$155
31984	Rock Crusher Cover	\$195
31985	Full Spider Diff. Guard	\$125
31985A	½ Spider Diff. Guard	\$79

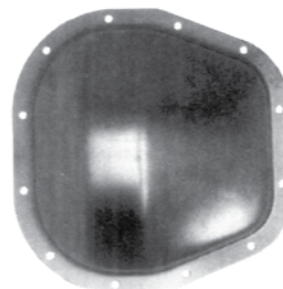
YOKES

31990	92/Down 1330 Series, U-Bolt Style, Short	\$189
31990A	92/Down 1350 Series, U-Bolt Style, Short	\$119
31991	93/Up 1330 Series, U-Bolt Style, Long	\$155
31992	93/Up 1350 Series, Strap Style, Long	\$165
31993	93/Up 1410 Series, Strap Style, Long	\$195

For the most up to date parts and pricing including sales, web only specials, and safe secure ordering, don't forget to log onto

www.broncograveyard.com

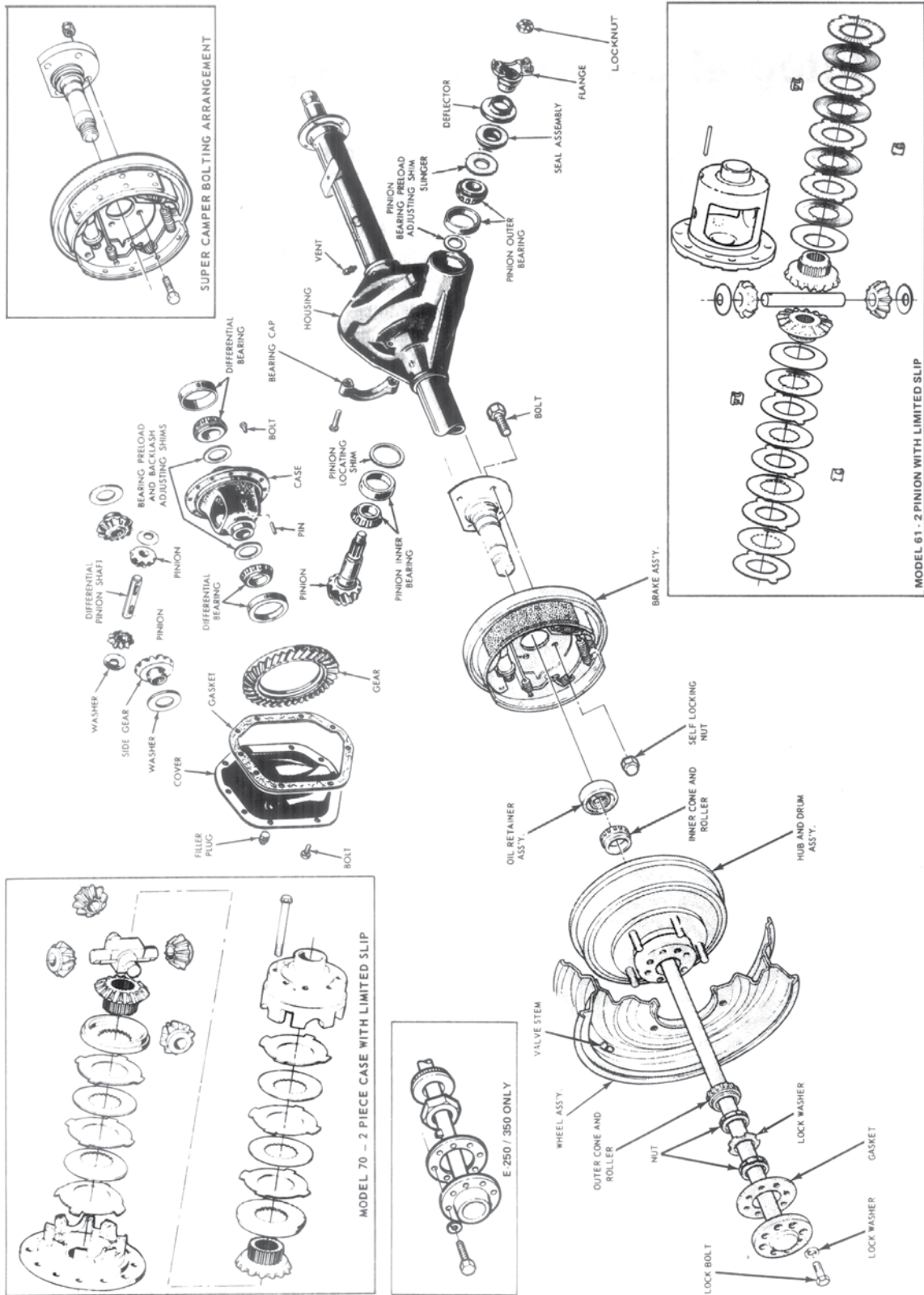

DANA 60 REAR

DANA 60 BRAKES

11806	Rear brake Drum	\$65
11806A	Rear Brake Shoes	\$42



MOSER FULL FLOAT AXLES

High performance non tapered full float axles are available in 16-35 spline for Dana 60 rears. Axles can be made in any length up to 39-5/8" and with any 8 lug pattern. Note: These axles are custom made to your specifications and therefore are non returnable. Please double check your information before ordering.



11840	Moser Full Float Axles (pair)	\$375
-------	-------------------------------	-------

RING & PINION

We offer only top quality gear sets for your Dana 60 in a variety of ratios to suit almost any need you may have.

11850	3.54 Ratio	\$342	11850E	4.88 Ratio	\$307
11850A	3.73 Ratio	\$342	11852F	5.13Ratio	\$307
11850C	4.10 Ratio	\$342	11852G	5.38 Ratio	\$307
11850C	4.30 Ratio	\$313	11852H	6.17 Ratio	\$388
11850D	4.56 Ratio	\$313	11852J	7.17 Ratio	\$407

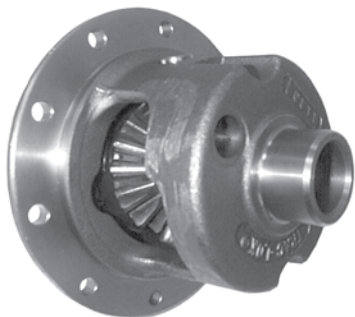
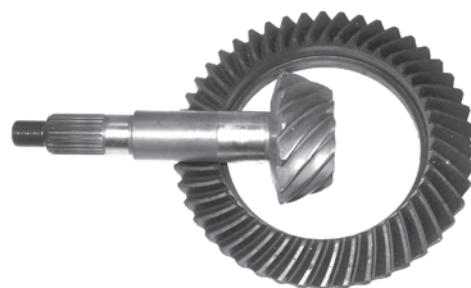

DIFFERENTIALS

11868	Trac-Lok 4.10/Down	\$427
11862	Powr-Lok 4.10/Down	\$576
11862A	Powr-Lok 4.56/Up	\$550
11865	Detroit Locker 4.10/Down	\$565
11865A	4.56/Up	\$569
11878A	Grizzly Locker, 30 Spline, 4.56/Up	\$561

YOKE

11893	1330 Series Dana 60 Yoke	\$107
11894	1350 Series Dana 60 Yoke	\$101
11895	Dana 60 Companion Flange(round)	\$132



DANA 80 REAR

RING & PINION

31880	Ring & Pinion 3.54 Ratio	\$381.48
31880A	Ring & Pinion 3.73 Ratio	\$267.22
31880B	Ring & Pinion 4.10 Ratio	\$267.22
31880BT	Thick Ring & Pinion 4.10 Ratio	\$376.19
31880C	Ring & Pinion 4.30 Ratio	\$446.26
31880D	Ring & Pinion 4.63 Ratio	\$359.96
31880E	Ring & Pinion 4.88 Ratio	\$553.19
31880F	Ring & Pinion 5.13 Ratio	\$425.67

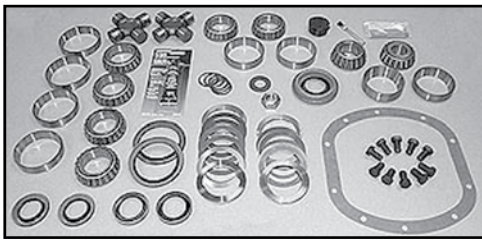
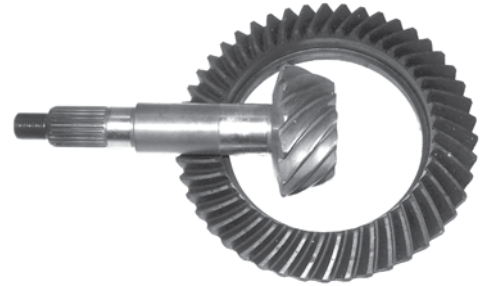

INSTALLATION KITS

31898	Master Overhaul Kit	\$189
31892	Complete Shim Kit	\$38

DIFFERENTIALS

31850	Bare Case, Open 3.73/down	\$199
31856A	Bare Case, Open 4.10/up	\$185
31856	Case+Internal Kit 4.10/up, 35 Spline, No ABS	\$399
31857	Case+Internal Kit 4.10/up, 37 Spline, No ABS	\$425
31858	Bare Case 4.10/up W/ABS	\$198
31859A	Internal Parts Kit 35 Spline	\$189
31859B	Internal Parts Kit 37 Spline	\$199
31860	ARB Air Locker 3.73/down 35 Spline	\$799
31862	ARB Air Locker 3.73/down 37 Spline	\$799
31870	Detroit Locker 4.10/up 35 Spline	\$709

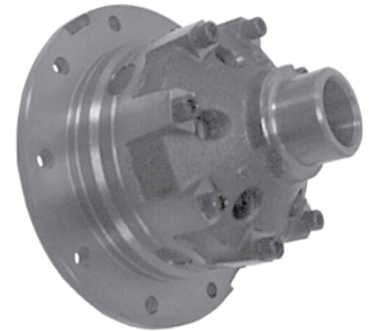

Detroit locker



Spider rock guard

MISCELLANEOUS

31830	OEM Cover	\$79
31832	Polished Aluminum Cover	\$159
30860	Spider Rock Guard	\$169
31888	D80 Pinion Seal	\$11
31889	D80 Pinion Nut & Washer	\$8.50
31885	D80 Pinion Yoke 1410 Series	\$125
31886	D80 Pinion Yoke 1480 Series	\$108

DANA 44 MONOBEAM FRONT

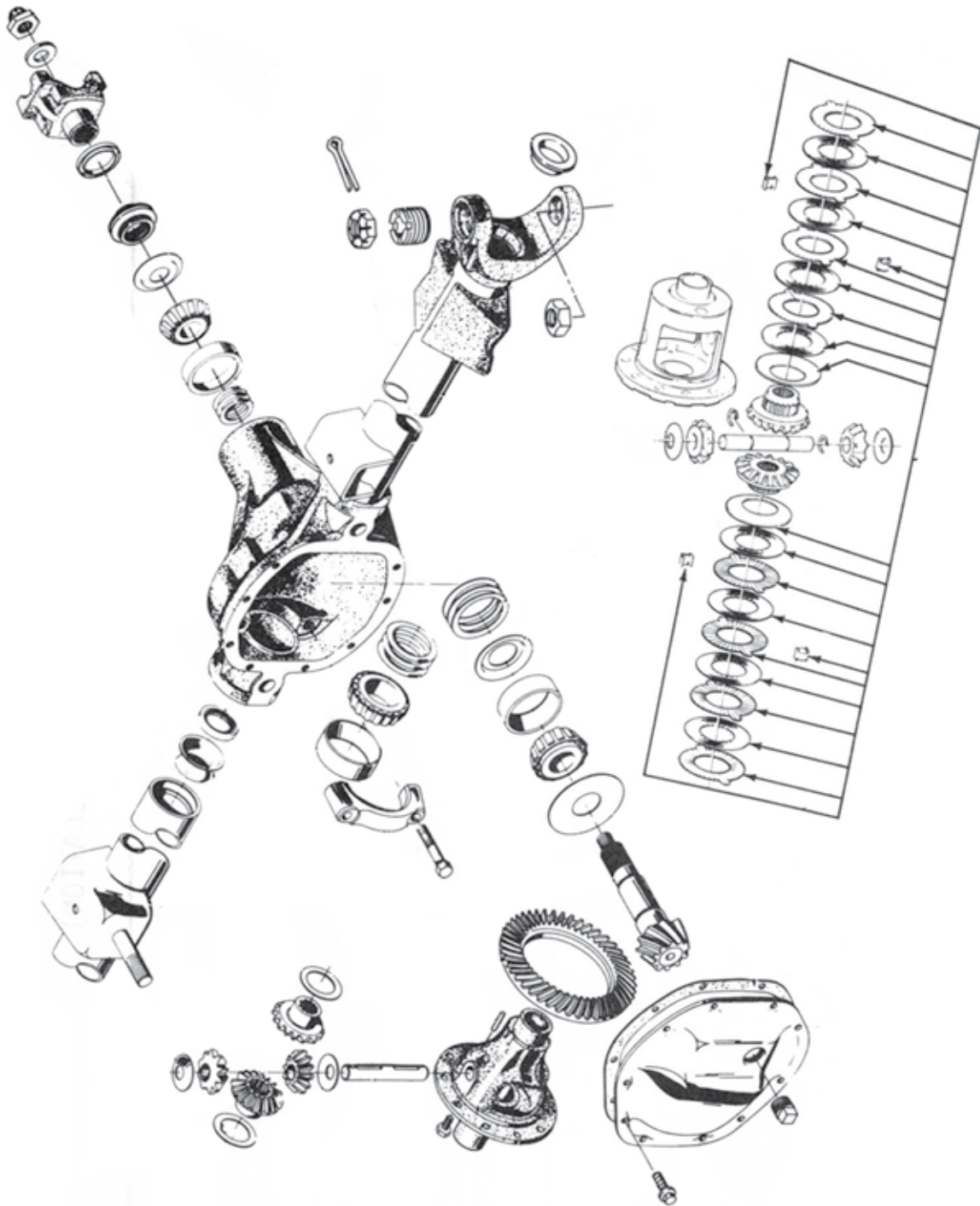

D44 MONOBEAM FRONT ENDS

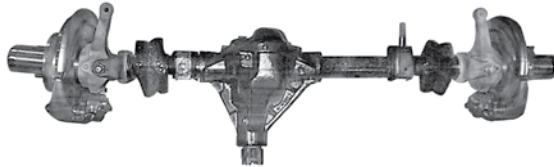

COMPLETE CUSTOM FRONT ENDS

From completely stock to extreme off-road. JBG is your source for complete front end units. Leave the dirty work to us! Contact one of our knowledgeable sales staff to have your custom front axle professionally built with your choice of gear ratio, differential, axle shafts etc. . .

22003	Complete Custom Rebuilt D44	\$Call
22001	D44 Housing Only (used)	\$400

RING AND PINIONS

All 1978-79 model Broncos and most 73-79 Pickups came equipped with a Dana 44 front axle. In a 73-77 D44 the pinion gear is positioned below the centerline of the axle. The 78-79 model D44's utilize a pinion gear that is located above the axle centerline. These differentials need a ring and pinion with the tooth angle reversed. This is referred to as reverse spiral bevel or reverse rotation. Replace yours with a quality Yukon Gear® gear set.

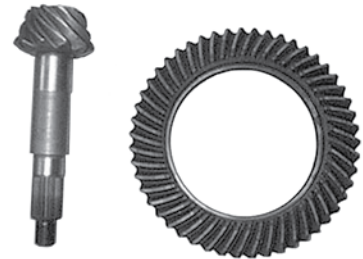

STANDARD ROTATION

12118B	3.54 Gear Ratio	\$276
12118E	4.09 Gear Ratio	\$224
12118G	4.56 Gear Ratio	\$224
12118H	4.88 Gear Ratio	\$224
12118J	5.13 Gear Ratio	\$241

REVERSE ROTATION

22060	3.54 Gear Ratio	\$240
22060B	4.09 Gear Ratio	\$311
22060C	4.56 Gear Ratio	\$227
22060D	4.88 Gear Ratio	\$227
22060E	5.13 Gear Ratio	\$227

USA STANDARD GEARS (REVERSE ROTATION)

22061	3.54 Ratio Value Gear	\$158
22061A	3.73 Ratio Value Gear	\$144
22061B	4.10 Ratio Value Gear	\$158
22061C	4.56 Ratio Value Gear	\$158
22061D	4.88 Ratio Value Gear	\$158





22070 Case Only

NON-LOCKING DIFFERENTIALS

Non-locking (open) differentials are what is found in most stock Dana 44 front ends. We carry quality OEM Dana/Spicer replacements for your broken or worn out unit.

12140	Complete Case 3.92/Down	\$139
12142	Complete Case 3.93/Up	\$140
12143	Case Only 3.92/Down	\$94
12145	Case Only 3.93/Up	\$89
12146	Internal Gear Kit	\$94

TRAC-LOK LIMITED SLIP DIFFERENTIAL

The Spicer Trac-Lok differential provides much greater traction than regular (open) differentials by distributing power equally to both wheels in low traction situations. This is achieved by a set of spring loaded clutches inside the differential which lock it up under straight line driving conditions but will allow for some slipping to occur while driving around corners, where the outside tire must travel faster than the inside tire.

22090	Bare Case Only 3.92/Down	\$148
22092	Bare Case Only 3.93/Up	\$148
22094	Complete Trac-Lok 3.92/Down	\$299
22096	Complete Trac-Lok 3.93/Up	\$279
22098	Trac-Lok Internal Gear Kit	\$229
22089	T/L Clutch Kit	\$65

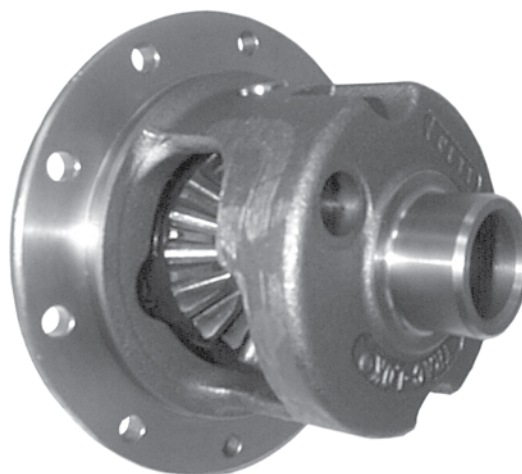

22094 Complet Trac-Lok

**TRUE-TRAC LIMITED SLIP DIFFERENTIALS**

Detroit true-trac was the first helical gear differential ever introduced into the automotive aftermarket. It remains the leading helical gear-type limited slip differential in the industry. Detroit Truetrac's proven helical gear design eliminates the need for wearable parts, resulting in maintenance free traction. Recognized not only for its durability but also it's smooth and quiet operation.

22107	True-Trac 3.92/Down	\$451
22108	True-Trac 3.93/Up	\$459

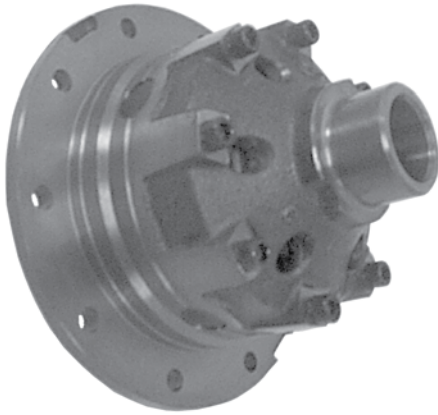

DETROIT LOCKER® DIFFERENTIALS

The Detroit Locker® is different than other limited slip differentials because it is a true mechanical positive lock-up differential. No clutches to wear out. Designed for severe operating conditions. Because of its rugged mechanical design, driver may hear and feel “backlash” going from drive to coast and coast to drive as reversing torque flow resets the components.

22117	Detroit Locker, 3.92/Down	\$579
22118	Detroit Locker, 3.93/Up	\$555
22080	Grizzly Locker, 292/Up	\$545

YUKON ZIP LOCKER

The Yukon Zip Locker is an air operated driver controlled locking differential activated by pushing a dash mounted button. When engaged, an on-board air compressor sends air to the differential. This activates an internal locking mechanism locking both axles. Push the button again and the air is released returning the unit to a fully open standard differential.

11922	Yukon Zip Locker, 3.92/Up	\$769
-------	---------------------------	-------

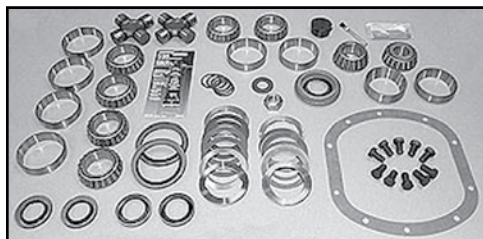

BEARING KITS

These bearing kits will assist anyone swapping a ring and pinion or doing a complete rebuild. **Gear install kit includes:** Pinion bearings, pinion shims, pinion seal, lock nut and cover gasket. **Overhaul kit includes:** All above parts and adds carrier bearings and shims. **Master kit includes:** Overhaul kit plus inner axle seals, hub seals, inner & outer wheel bearings, and U-Joints.

12133	Gear Install Kit	\$65
12134	Overhaul kit	\$89
22114	Master Kit 78-79 Bronco 73-79 F100/150	\$225
12129	Dana 44 Seal & Shim Kit	\$29



STANDARD AXLE SHAFTS

Bolt-in direct replacements for your stock axle shafts.

22021	RH Inner Axle, 78-79 Bronco, 76-79 PU	\$104
22022	RH Axle Set (inner, outer & joint)	\$169
22025	LH Inner Axle, 78-79 Bronco, 76-79 PU	\$113
22026	LH Axle Set (inner, outer & joint)	\$184
22028	Outer Shaft 78-79 Br. 73-79 F100/150	\$49

CHROMEMOLY AXLE SHAFTS

These Yukon Chrome Moly axle shafts are 30% stronger than the stock Dana 44 shafts, making them about equal to the stock 78-79 Dana 60 front shafts. Using these shafts with the Dana/Spicer U-joint will help get you one seriously stout front axle!



22029	78-79 ChromeMoly Outer Axle	\$75
22030	78-79 ChromeMoly Inner LH Axle	\$125
22031	78-79 ChromeMoly Inner RH Axle	\$125
22032	78-79 LH Complete Inner & Outer W/Joint & Slinger	\$225
22033	78-79 RH Complete Inner & Outer W/Joint & Slinger	\$225
22034N	RH & LH Set (no u-joints)	\$345
22056	Dana/Spicer U-Joint	\$30

MOSER MAX AXLE SHAFTS

Step up to the strongest off-road axles on the market! Manufactured from custom alloy and beefed up with extra material around the U-Joint. These shafts will accept either the stock or the full circle retainer clips. Complete inner and outer axle shaft with U-Joint. Assembly required. Custom made. Please call to order.



22036	Inner & Outer Axle W/ U-joint	\$350
22038	Complete Set RH and LH	\$695

YUKON HARDCORE AXLES

22040	Yukon Hardcore Axle Set (no joints)	\$579
22041	Yukon Hardcore Axle, LH Inner	\$159
22042	Yukon Hardcore Axle, RH Inner	\$179
22043P	Yukon Hardcore Axle, Outer (pair)	\$119



U-JOINTS & MISCELLANEOUS

22056	Spicer U-Joint, 78-79 Br. 73-79 F100/150	\$30
22052	Outer Axle Slinger, 78-79 Br. 73-79 F100/150	\$4
22054	Inner Axle Seal, 78-79 Br. 73-79 F100/150	\$6
22059	Yukon "Super Joint" U-Joint	\$330

SPINDLE AND RELATED

22140	Spindle, 78-79 Bronco 76-79 F150	\$79
22148	Spindle Bearing Kit, 78-79 Bronco, 73-79 F100/150	\$10
22150	Spindle Nuts & Washer, 78-79 Bronco, 73-79 F100/150	\$10
22152	Spindle Stud (each)	\$4
12225	D44 Spindle Stud Nut (each)	\$.75
12205	Galvanized Disc Brake Dust Shields, Pair	\$39

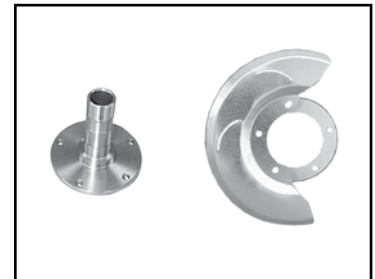

HUB AND ROTOR ASSEMBLY

These hub and rotor assemblies are direct bolt on replacements for your original unit. Each comes factory assembled with new hub, rotor, wheel studs, and wheel bearing races installed. Just add our install kit (includes hub seal and Timken wheel bearings) to finish the job.

22159	Hub & Rotor, 78-79 Bronco, 76-79 F150	\$99
22159K	Hub & Rotor Install Kit	\$19

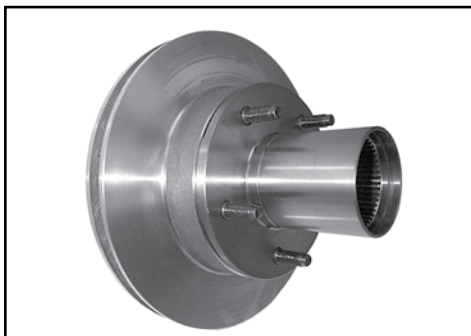

HUBS AND RELATED

- 22160 Hub, 78-79 Bronco/76-79 F150 \$79
- 22164 Hub Seal, 78-79 Bronco/73-79 F100/150 \$4
- 22166 Wheel Stud \$1.50
- 22154 Inner Wheel Bearing, 78-79 Bronco/F100/150 \$15
- 22156 Outer Wheel Bearing, 78-79 Bronco/F100/150 \$13

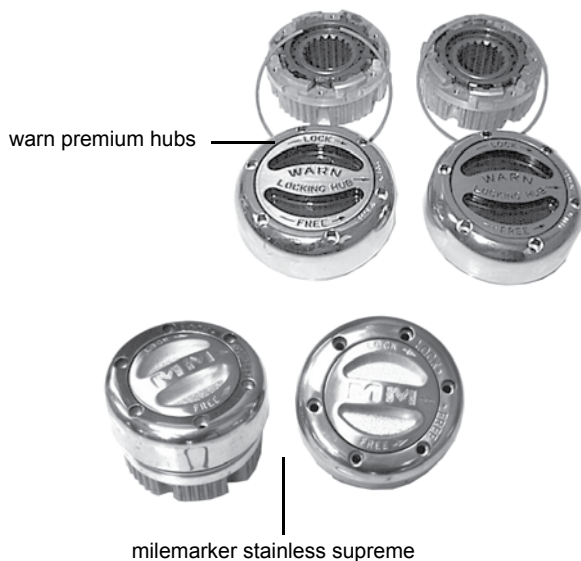
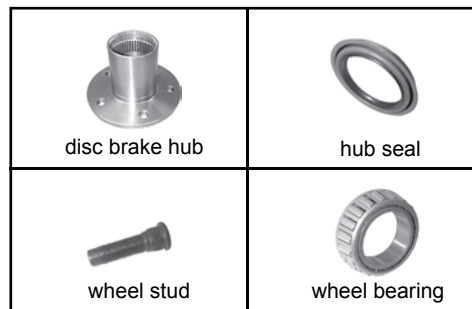

WARN LOCK OUT HUBS

Replace your old, sticky, hard to turn stock hubs with these premium units from Warn & Milemarker. Warn features include rapid positive engagement, double sealed to keep out contaminants, and have corrosion resistant chrome finish. Milemarker features a stainless steel outer jacket with the latest patented technology and decidedly smooth operation with a limited lifetime warranty.

- 22197 Warn Standard Lock-out Hubs, pair \$75
- 22198 Warn Premium Lock-out Hubs, pair \$95
- 22188 Milemarker Stainless Supreme Hubs \$69

BALL JOINTS

Step up to the finest quality ball joint on the market. These Dana/Spicer ball joints are just like the factory Ford units. Sold in pairs (one upper and one lower). Includes attaching hardware.

- 22185 Ball Joints, 78-79 Bronco/73-79 F100-250 \$59



PINION FLANGE & RELATED



- 22122 Pinion Flange, 1310 Series U-Joint \$42
- 22124 Pinion Flange, 1330 Series U-Joint \$52
- 22126 Pinion Flange, 1350 Series U-Joint \$98
- 22119 Pinion Seal \$5
- 22120 Front Differential Cover Gasket \$4
- 22121 Pinion Nut & Washer \$5

SUPERLIFT EXTREME RING DIFFERENTIAL GUARD

Protect the lowest hanging part of your vehicle! These Superlift Extreme rings are constructed of laser cut 1/4" steel plate. The ring reinforces the seal area while providing valuable frontal protection. For durability, Extreme Rings are finished in a yellow/gold zinc chromate.

10839	D30 Std Rock Guard	\$98
10840	D44 Std Rock Guard	\$98
10842	D60 Front Rock Guard	\$98
10844	D60 Rear Rock Guard	\$98
10847	8.8" Rear Rock Guard	\$98



YUKON SUPER JOINT

For people looking for the ultimate in off-road performance, this patented design doesn't utilize needle bearings, so they rely on offset hardnesses to protect against wear. The caps will wear out first and can be replaced at a lower cost than buying an entire new u-joint.

22057	Yukon Super Joint	\$200
-------	-------------------	-------

AXLE VENT

Aluminum axle vent. 7/16" dia. 20 threads per inch.

12390	Axle Breather Vent, New	\$12
-------	-------------------------	------

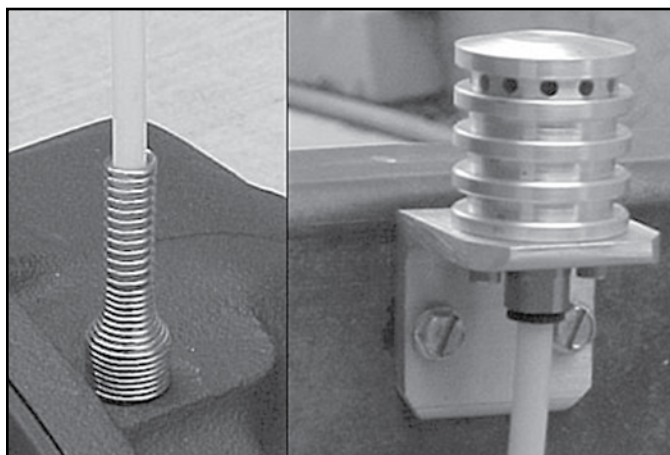

FRONT END ACCESSORIES

The Purple Cranium Products Inc. Diff-Air Cleaner is Manufactured from 6061 T-6 Billet Air Craft Aluminum and uses a blue rigid polyester fiber to filter the incoming air as the differential "breathes." This air cleaner will filter debris from contaminating your bearings, gears and fluid. The remote mount unit also reduces risk of water infiltration because the filter can be mounted almost anywhere, high and dry.

12096	Direct Mount Diff Filter	\$32
12097	Remote Mount Diff Filter	\$58
33949	C-Bushing Tabs, New	\$89



FRONT COVER

JBG has a variety of options when it comes to covering your front end. Whether it's a chrome cover for your early model front end or the stock cover for your later model reverse rotation front, JBG has you covered.

12114C	Chrome Front Cover, Dana 44	\$25
12114G	Front Cover Gasket, Dana 44	\$4
22132	Front Cover D44 High Fill (reverse rotation)	\$19
12114B	Dana 30/44 Cover Bolts (set of 10)	\$4
12114A	Aluminum Front Cover Dana 44	\$109

DIFFERENTIAL COVERS BY SOLID AXLE IND.

Thick Nodular iron casting with reinforcing ribs helps add rigidity to weak factory housings.

12114N	Nodular Iron Cover, D44	\$75
11802	Nodular Iron Cover, D60	\$75
31986	Nodular Iron Cover, Ford 10¼	\$85
32346	Nodular Iron Cover, Ford 8.8"	\$75

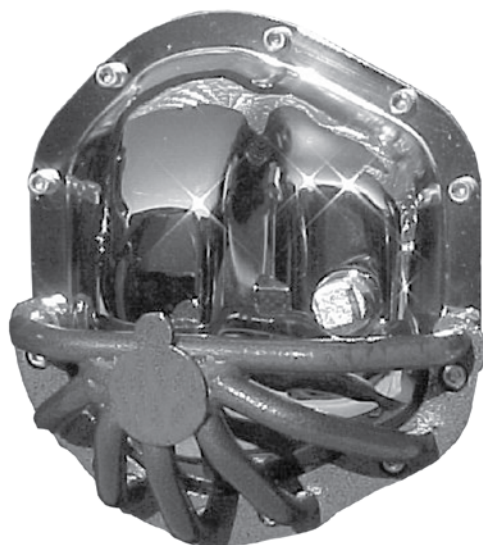

SPIDER
FROM PURPLE CRANIUM PRODUCTS

Protect your front differential with one of these **Spider** rock guards manufactured by Purple Cranium Products. These heavy duty guards feature a CNC Plasma cut normalized flange, jig drilled holes and bores, counterbored mounting holes, fixture mig welded, blanchard ground mating surface and gray powder coat finish. Stainless mounting hardware included.

20832	Dana 44 Spider Rock Guard	\$99
20834	Dana 60 Spider Rock Guard (front)	\$99
20836	Dana 60 Spider Rock Guard (rear)	\$165
20838	9 Inch Spider Rock Guard	\$165

Polyurethane for Monobeam Dana 44



14 PIECE C-BUSHING KIT

Replace your rotted or worn out C-Bushings with these superior polyurethane units. Firmer than rubber bushings to improve control and stability. 14 piece set includes C-bushings, radius arm bushings, and trac-bar bushings. 2° kit for stock applications, 4° kit for lifts up to 2½", and the 7° kit for lifts over 2½". Your choice of black or red.

23000	2° Kit (black)	\$50	23005R	4° (red)	\$50
23000R	2° Kit (red)	\$50	23010	7° (black)	\$50
23005	4° Kit (black)	\$50	23010R	7° (red)	\$50

C-BUSHINGS ONLY

Your choice of black or red.

23015	2° Kit (black)	\$30
23015R	2° Kit (red)	\$30
23020	4° Kit (black)	\$30
23020R	4° Kit (red)	\$30
23025	7° Kit (black)	\$30
23025R	7° Kit (red)	\$30

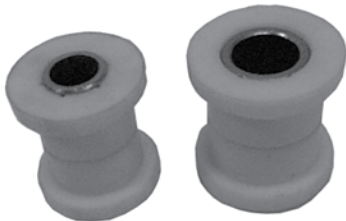

TRAC-BAR BUSHINGS

23030	Trac-Bar Bushings (black)	\$11
23030R	Trac-Bar Bushings (red)	\$11

RADIUS ARM BUSHINGS

23035	Radius Arm Bushings (black)	\$17
23035R	Radius Arm Bushings (red)	\$17



STAGE 8 LOCKING FASTENERS



X-LOCK LOCKING SPINDLE NUTS

The Locking Spindle Nut assembly is easily installed without any specialized tools and spindle nut itself can be locked within 1/2 degree of any position so you will never have to over or under torque and will maintain the required bearing preload value. This extremely tough innovation withstands severe reverse torque, a real plus when you're 25 miles away from civilization.

12223	Dana 30/44 X-Lock Locking Spindle Nuts	\$54
11704X	Dana 60 X-Lock Locking Spindle Nuts	\$54

STAGE 8 HEADER BOLTS

10048	170/200 Stage 8 Header Bolts	\$39
10049	Small Block 3/4" Header Bolts	\$43
10050	Small Block 1" Header Bolts	\$53
10051	Stainless Small Block Header Bolts	\$74
10052	300 Six Cyl Header Bolts	\$47
10053	Big Block 3/4" Header Bolts	\$43
10054	Big Block 1" Header Bolts	\$53
10055	Collector Flange Bolts	\$17

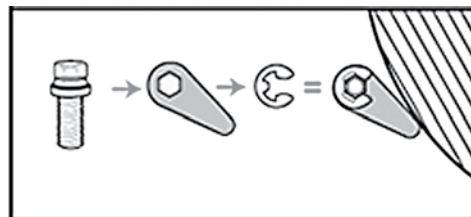

OTHER STAGE 8 KITS

11190	C4 Trans Pan Bolt Kit	\$29
11191	C6 Trans Pan Bolt Kit	\$34
10145	302 Oil Pan Bolt Kit	\$26
10760	Distributor Hold Down Bolt	\$5
10787B	Valve Cover Bolt Kit	\$19

Measuring for custom length driveshafts.

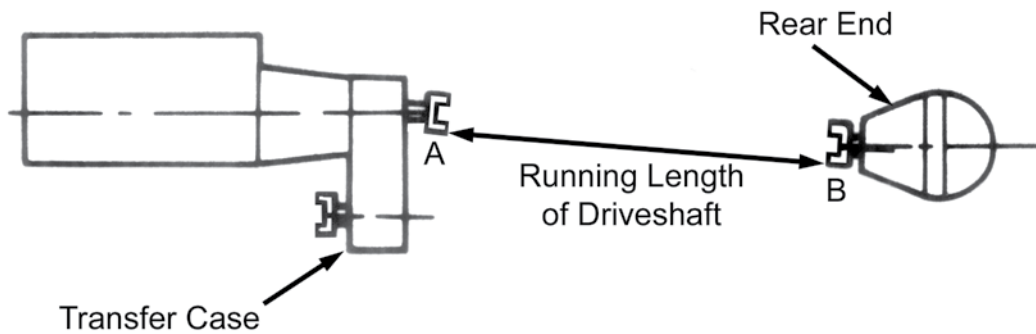

Adding lift kits or modifying drivetrain components often results in the need for custom length driveshafts. An accurate running length measurement is crucial when building these custom shafts. Running length is the distance between the outermost U-Joints of the driveshaft from center to center. The best way to obtain this measurement is as follows:

- 1) Make sure vehicle is on level ground.
- 2) Make sure vehicle weight is resting normally on the suspension (not on jackstands), as if you had just parked the vehicle and got out.
- 3) Referring to the above illustration, take measurement between point A and B. Measuring from the flat surfaces on the yokes (where the driveshaft attaching U-Bolt holes are located) will insure proper center to center measurement of U-Joints.
- 4) The resulting measurement is the proper running length required for the driveshaft.

Anatomy of a driveshaft.

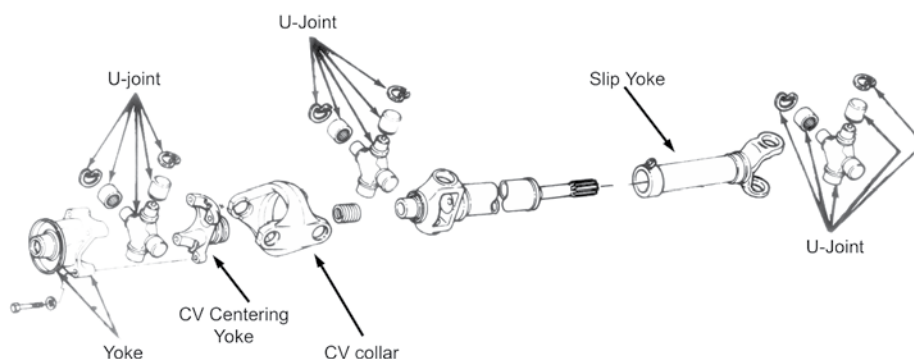

DRIVESHAFTS

FRONT DRIVESHAFT (BRONCO)

Replace your worn out driveshaft with one of these new ready to bolt in units. Made in the USA.



32400	1980-87 Bronco, Compressed Length 32 ³ / ₁₆ "	\$165
32401	1988-90 Bronco, Compressed Length 39 ³ / ₈ " W/C-6 Trans	\$165
32402	1988-96 Bronco, Compressed Length 35 ¹³ / ₁₆ " W/5 Spd Manual Trans	\$189
32403	1988-93 Bronco, Compressed Length 34 ³ / ₄ " W/AOD Auto Trans	\$169
32404	1990-96 Bronco, Compressed Length 41" W/E4OD Auto Trans	\$169

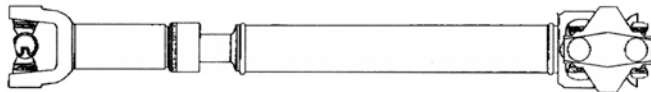

FRONT DRIVESHAFT (F-150)

Same as above except designed to fit your F-150. Ready to bolt in. Made in the USA.

32402	1988-96 F-150, Compressed Length 35 ¹³ / ₁₆ " W/5 Spd Man Trans	\$189
32403	1988-93 F-150, Compressed Length 34 ³ / ₄ " W/AOD Auto Trans	\$169
32404	1990-96 F-150, Compressed Length 41" W/E4OD Auto Trans	\$169
32420	1982-85 F-150, Compressed Length 32 ³ / ₁₆ "	\$169
32421	1985-93 F-150, Compressed Length Of 34 ³ / ₄ " W/AOD Auto Trans	\$169
32422	1986-87 F-150, Manual Trans & Auto Trans, All	\$169
32423	1988-96 F-150, W/Compressed Length 39 ³ / ₈ "	\$169

REAR DRIVESHAFT (80-89 BRONCO)

Our Bronco rear driveshafts offer the same quality American made construction as our front shafts.



32405	1980-82 Bronco, Compressed Length 30 ¹ / ₂ "	\$239
32406	1983-84 Bronco, Compressed Length 30 ¹ / ₁₆ "	\$235
32407	1985-87 Bronco, Compressed Length 29 ³ / ₁₆ "	\$249
32407A	1987 Bronco, Compressed Length 29 ¹³ / ₁₆ " W/AOD Trans	\$249
32407B	1987 Bronco W Manual Trans and Compressed Length Of 29 ¹³ / ₁₆ "	\$249
32408	1988-89 Bronco W/AOD Comp. Length 31 ¹ / ₂ "	\$239
32409	1988-89 Bronco W/5 Speed Manual Comp. Length 27 ¹ / ₄ "	\$239
32410	1988-89 Bronco W/C-6 Auto Comp. Length 29 ¹ / ₂ "	\$239
32412	1988-89 Bronco W/4 Speed Manual Transmission	\$239

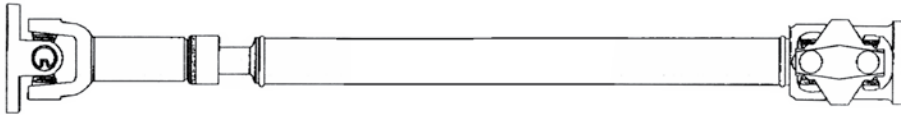

REAR DRIVESHAFT (90-96 BRONCO)

32414	1990-96 Bronco W/3 Spd Auto Or 4 Spd Manual Trans. Comp. Length 32½"	\$239
32415	1990-96 Bronco W/4 Spd Auto (AOD) Comp. Length of 31½"	\$249
32416	1990-96 Bronco W/E4OD and Compressed Length of 26⅞"	\$249
32418	1990-96 Bronco W/5 Spd Manual and Compressed Length of 29⅞"	\$249



DRIVESHAFT REPAIR (1980-89)

Driveshaft repair kit includes: 3 U-Joints and CV head (includes ball, socket and seal).

32489	Driveshaft Repair Kit (80-89)	\$70
32484	CV Head 1330 Series (80-89)	\$30
32484A	CV Ball & Spring Kit (80-89)	\$12
32486A	CV Collar/H-Yoke (80-89)	\$35
32484B	CV Attaching Bolt	\$1

DRIVESHAFT REPAIR (1990-96)

Driveshaft repair kit includes: 3 U-Joints and CV head (includes ball, socket and seal).

32486	Driveshaft Repair Kit (90-96)	\$105
32485	CV Head (90-96)	\$55
32485B	CV Head Dust Shield	\$4
32485A	CV Ball & Spring Kit(90-96)	\$14
32486A	CV Collar/H-Yoke (90-96)	\$35
32487	Driveshaft Boot	\$24
32484B	CV Attaching Bolt	\$1
32492	Companion Flange (90-96) 1330 Series	\$45

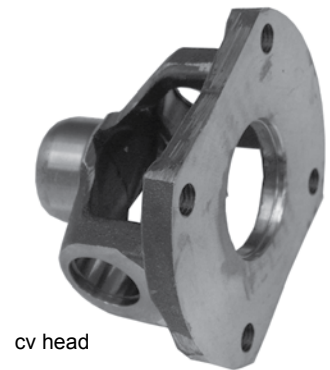

cv head

MISCELLANEOUS PARTS



32480	Slip Yoke, Front Shaft 1980-96 Bronco/F-150	\$40
32481	Slip Yoke, Rear Shaft 1980-96 Bronco/F-150	\$40
32482	U-Joint (Dana Spicer)	\$16.50
32486B	U-Joint Attaching Hardware	\$5.00

**JBG STOCKS ALL BRAKE PARTS FOR YOUR
1980-96 F150, F250 AND F350 INCLUDING:**

Master Cylinders

Rotors

Front Brake Pads

Drums

Brake Shoes

Brake Hoses

Wheel Cylinders

Rear Brake Spring Hardware

Self Adjuster Kits

Performance Rotors

Performance Brake Pads

**PLEASE CALL OR CHECK OUR WEBSITE
FOR YOUR APPLICATION**



BRAKES



VACUUM BOOSTER

32500	Rebuilt Brake Booster, 1980-83*	\$125
32500A	Rebuilt Brake Booster, 1983-87*	\$135
32500B	Rebuilt Brake Booster, 1987-88*	\$135
32500C	Rebuilt Brake Booster, 1989-93*	\$135
32500D	Rebuilt Brake Booster, 1994-96*	\$135

*\$30 refund with return of old booster

MASTER CYLINDER

32504	Master Cyl, New, 80-86	\$35
32504A	Master Cyl, New, 87-03\87	\$65
32504B	04\87-93 & 94-96 W/O Cruise	\$45
32504C	Master Cylinder, 88-96 Bronco	\$45
32504D	94-96 W/Cruise	\$75

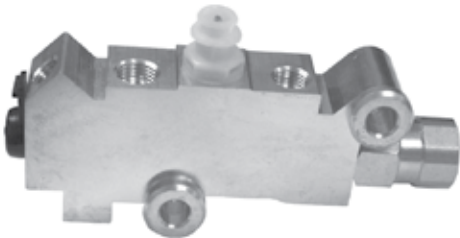
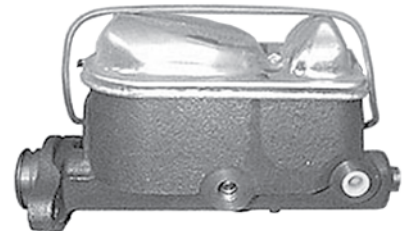

PROPORTIONING VALVE

22519	Aftermarket Pro-Valve	\$59
32519A	Brake Light Warning Switch	\$26

FRONT PADS

Raybestos service grade brake pads. Engineered for safe, quiet operation.

32531	Front Brake Pads, 80-86 Bronco/F150	\$15
32532	Front Brake Pads, 87-93 Bronco/F150	\$15
32533	Front Brake Pads, 94-96 Bronco/F150	\$15



Raybestos
The best in brakes®

REAR BRAKE SHOES

32543	Standard Duty Brake Shoes, 80-96	\$25
-------	----------------------------------	------

REAR DRUMS

32370	Brake Drum, 1980-86 Bronco/PU	\$40
32372	Brake Drum, 1987-96 Bronco/PU	\$40

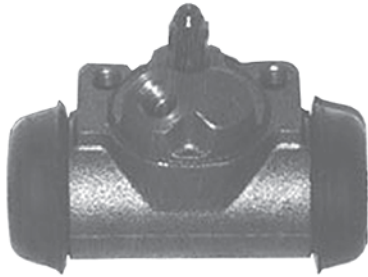
**REAR BRAKE HARDWARE**

32530	Rear Brake Spring Kit, 1980-82	\$10
32530A	Rear Spring Kit, 1983-96	\$10
32540R	Wheel Cylinder, RH, 1980-96	\$10
32540L	Wheel Cylinder, LH, 1980-96	\$10
32538	Self Adjuster Kit, LH, 1980-96	\$12
32539	Self Adjuster Kit, RH, 1980-96	\$12

FRONT BRAKE HOSES*

32560L	Front Outer Hose, LH, 1980-89 Bronco/F-150	\$13
32560R	Front Outer Hose, RH, 1980-92 Bronco/F-150	\$13
32561L	Front Outer Hose, LH, 1990-92 Bronco/F-150	\$13
32561R	Front Outer Hose, RH, 1990-92 Bronco/F-150	\$13
32562L	Front Outer Hose, LH, 1993 Bronco/F-150	\$19
32562R	Front Outer Hose RH, 1993 Bronco/F-150	\$19
32563L	Front Outer Hose LH, 1994-96 Bronco/F-150	\$18
32563R	Front Outer Hose, RH, 1994-96 Bronco/F-150	\$18



* Many applications not listed. Please call.

**REAR BRAKE HOSES**

32550	Rear Brake Hose, 1980-87 Bronco/F-150	\$14
32550A	Rear Brake Hose, 1988-91 Bronco/F-150	\$14
32550B	Rear Brake Hose, 1992-96 Bronco/F-150	\$17
52562C	Rear Brake Hose, 1980-84 F-250 4X4	\$15
62562A	Rear Brake Hose, 1980-84 F-350 4X4	\$15

STANDARD BRAKE LINE KIT

Make a miserable job easier with these brake line sets from JBG. Each set is pre-bent to fit your application and make installation a breeze.

32520	80-86 Bronco	\$150
32522	87 Bronco	\$150
32524	93 Bronco	\$155
32526	94-96 Bronco	\$155
42578	80-86 F-150, 4X4, 8' bed	\$150
42580A	87-90 F-150, 4X4, 8' Bed	\$155
52599C	80-86 F-250, 4X4, 8' Bed	\$150
62597B	80-86 F-350, 4X4, 8' Bed	\$155
62597	87-90 F-350, 4X4, 8' Bed	\$155

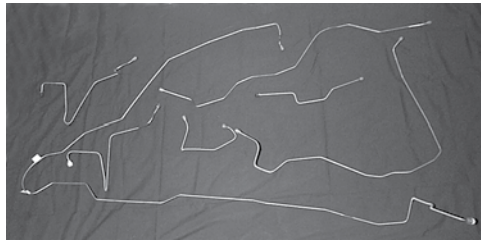
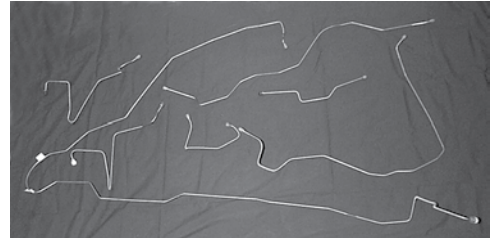

see more brake line kits at

WWW.BRONCOGRAVEYARD.COM

STAINLESS BRAKE LINE KIT

Just like the standard brake line kit above except made from high quality stainless steel tubing. Say goodbye to rust.

32520SS	80-86 Bronco	\$170
32522SS	87 Bronco	\$175
32524SS	93 Bronco	\$175
32526SS	94-96 Bronco	\$175
42581A	87-90 F-150, 4X4, 8' Bed	\$185
52599D	80-86 F-250, 4X4, 8' Bed	\$185
62597D	80-86 F-350, 4X4, 8' Bed	\$185
62597E	87-90 F-350, 4X4, 8' Bed	\$185

CALIPERS

32570	1980-85 Bronco/Pick-up RH Rebuilt Caliper	\$33
32571	1980-85 Bronco/Pick-up LH Rebuilt Caliper	\$33
32572	1986-93 Bronco/Pick-up RH New Caliper	\$35
32573	1986-93 Bronco/Pick-up LH New Caliper	\$35
32573A	1994-96 Bronco/Pick-up RH New Caliper	\$40
32573B	1994-96 Bronco/Pick-up LH New Caliper	\$40

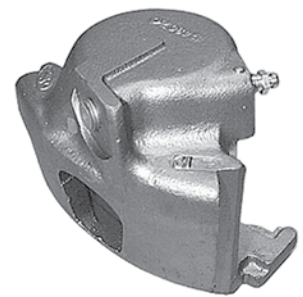

DUST SHIELDS

32116	Brake Dust Shield, 1980-93, RH	\$69
32117	Brake Dust Shield, 1980-93, LH	\$69
32118	Brake Dust Shield, 1994-96, RH	\$99
32119	Brake Dust Shield, 1994-96, LH	\$65



BRONCO/F-150 ROTOR

32110	Disc Rotor 80-86, 88-93 Bronco/Pick-up	\$30
32112	Disc Rotor 94-96 Bronco/Pick-up	\$29
32114	Disc Rotor 1987 Only Bronco/Pick-up	\$30

HUB & ROTOR ASSEMBLY

32574	Hub & Rotor 80-86	\$99
32574A	Hub & Rotor 88-92	\$99
32574B	Hub & Rotor 94-96 W/4Wheel ABS	\$99
32574C	Hub & Rotor 94-96 W/Rear Wheel ABS	\$99



HIGH PERFORMANCE ROTORS

Raybestos® Extreme ventilated brake rotors are for light trucks that brake many times in quick succession, especially at high speeds, and vehicles that carry heavy loads. Examples include ambulances, taxi cabs, fire, police and rescue vehicles, commercial, delivery, construction and postal vehicles; and high performance vehicles. For these and other severe duty applications, Raybestos® Extreme drums and rotors brake better, last longer and are an outstanding value.



Full cast and composite rotors are available for correct original equipment match

Hub-and-rotor models have heat-treated wheel studs and bearing races, for superior durability

4 WHEEL DRIVE

32580L	80-93 Bronco/F-150 LH	\$79
32580R	80-93 Bronco/F-150 RH	\$79
32581L	94-96 Bronco/F-150 LH	\$79
32581R	94-96 Bronco/F-150 RH	\$79

2 WHEEL DRIVE

32585L	80-93 F-150 LH	\$99
32585R	80-93 F-150 LH	\$99
32586L	94-96 F-150 W/ABS	\$99
32586R	94-96 F-150 W/ABS	\$99

Please call for F-250 & F-350 applications.

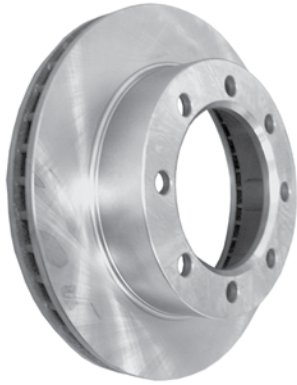

F-250 ROTORS

Raybestos® premium rotors meet original equipment fit, form and function specifications. These rotors provide peace of mind by providing safe, consistent, smooth braking each and every time the brakes are applied.

2 WHEEL DRIVE

52526	80-86, 2WD Rotor	\$75
52526A	80-85, W/Dual Piston Caliper (under 8500 GVW)	\$75
52526B	80-85, W/Dual Piston Caliper (over 8500GVW)	\$76
52526C	86-94, W/Dual Piston Caliper	\$75
52526D	95-96, 2WD Rotor	\$59
52526E	97 2WD Rotor	\$63

4 WHEEL DRIVE

52528	80-94, 4X4 Rotor	\$45
52528B	80-87, Hub & Rotor (1/2" studs, 3800lb. axle)	\$129
52528C	80-87, Hub & Rotor (9/16" studs, 3800lb. axle)	\$129
52528D	80-87, Hub & Rotor (1/2" studs, 4600lb. axle)	\$129
52528E	80-87, Hub & Rotor (9/16" studs, 4600lb. axle)	\$129
52528H	95-97, Rotor (w/4600lb. axle)	\$45
52528J	95-97, Rotor (over 8600lb GVW)	\$45



EXTREME DUTY BRAKE PADS

Raybestos Extreme Performance brake pads are designed for applications requiring only the highest performance. Police, highway patrol, ambulance and other vehicles where stopping better, faster, and quicker is mandatory, should use this unique asbestos-free formulation of friction materials (works best with the performance rotors).

32580	80-86, Bronco Extreme Pads	\$38
32580A	87-93, Bronco Extreme Pads	\$40
32581	94-96, Bronco Extreme Pads	\$55
52514SD	91-94, F-250 4X4 Extreme Pads	\$42
52515SD	95-97, 4X4 F-250 Extreme Pads	\$42
62513SD	91-94, F-350 Extreme Pads	\$42
62514SD	95-97, F-350 Extreme Pads	\$42

Welcome to Hydratech Braking Systems

High Performance Hydraulic Brake Assist Systems

Welcome to the world of truly better braking! These high performance hydraulic brake assist systems are capable of producing substantial gains in overall available braking power. These assist systems provide the following features:

- * Substantially improved clearance from brake booster to engine valve covers.
- * Highly enhanced overall braking capabilities with greater overall power.
- * Not affected by large duration camshafts or forced induction systems.
- * Smooth, linear braking action, regardless of engine speed and vacuum.
- * Ultra rugged and reliable, assist units matching or exceeding OEM quality
- * Featuring the fastest actual brake response time of any power brake system.

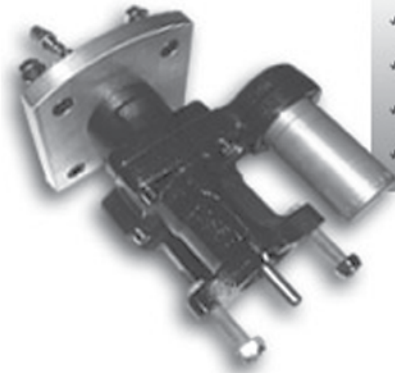

HYDROBOOST BRAKING SYSTEM

Sometimes referred to as "hydro-booster" or "hydra-vac". Hydroboost is a high performance hydraulic brake assist booster, which is a powerful alternative to a vacuum assist type booster. This type of assist unit uses the hydraulic pressure from the power steering system to provide a potent brake pedal assist. System works with all engines which have power steering pump in the stock location and also works with ABS brakes. Compatible with the stock master cylinder.

If you're having trouble with your vacuum assist brakes due to a high duration camshaft or supercharging, then this kit will really put some strong and reliable brakes back into the picture. If you are upgrading from manual brakes, you will be pleased with simple straightforward simple to install design as well as the tremendous improvement in braking power.

32599 Hydroboost Braking System 83-96 Bronco/F-Series

\$760

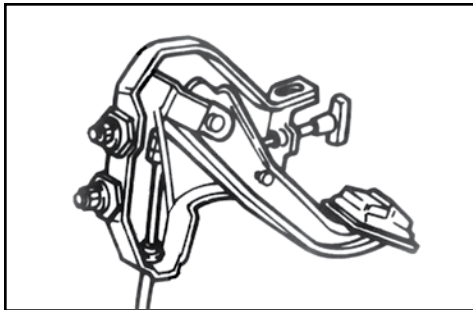

MISCELLANEOUS PARK BRAKE

32690	Brake Pedal Assembly (used)	\$60
32692	Spreader Bar 11" (used)	\$10
32694	Actuating Arm RH (used)	\$10
32696	Actuating Arm LH (used)	\$10
32699	Cable Retaining Clip	\$2

REAR DISC BRAKE CONVERSIONS

Our rear disc brake conversion kit includes all brackets and hardware required for you to convert your inferior drum brake system to this superior performing rear disc brake system. These conversion kits use G.M single piston calipers and part # D-154 Pads, have 7" caliper mounting screw spacing, and 1" wide rotors. If a parking brake is not a priority, the front calipers from a 78-83 Monte Carlo will be needed. Those looking to retain the E-brake setup will need the rear calipers from a 79-85 El Dorado, Riviera, or Tornado (along with the miscellaneous parts for the linkage). The rotors are custom drilled pieces that are readily available for replacement if needed. All kits require our stainless steel hoses to tie into the existing brake system. We save you \$\$\$ by only including the custom parts needed for the conversion, allowing you to locate the common parts locally (parts store/bone yard.) An adjustable proportioning valve may be needed to achieve proper front to rear braking balance.

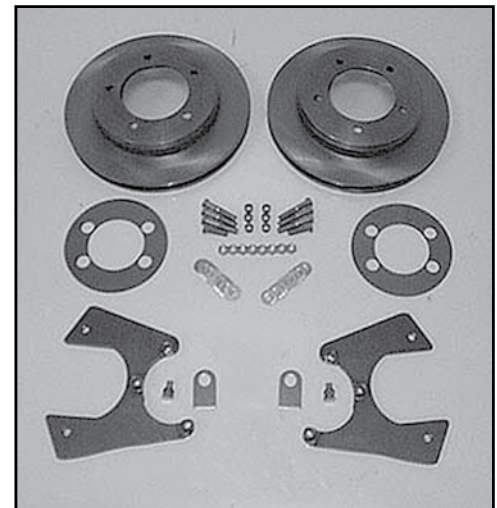

32241	80-86 Rear Disc Brake Conversion, 9" Rear	\$295
32375	83-96 Rear Disc Brake Conversion, 8.8" Rear	\$295
32376	80-96 Stainless Brake Hoses (pair)	\$55



PARKING BRAKE

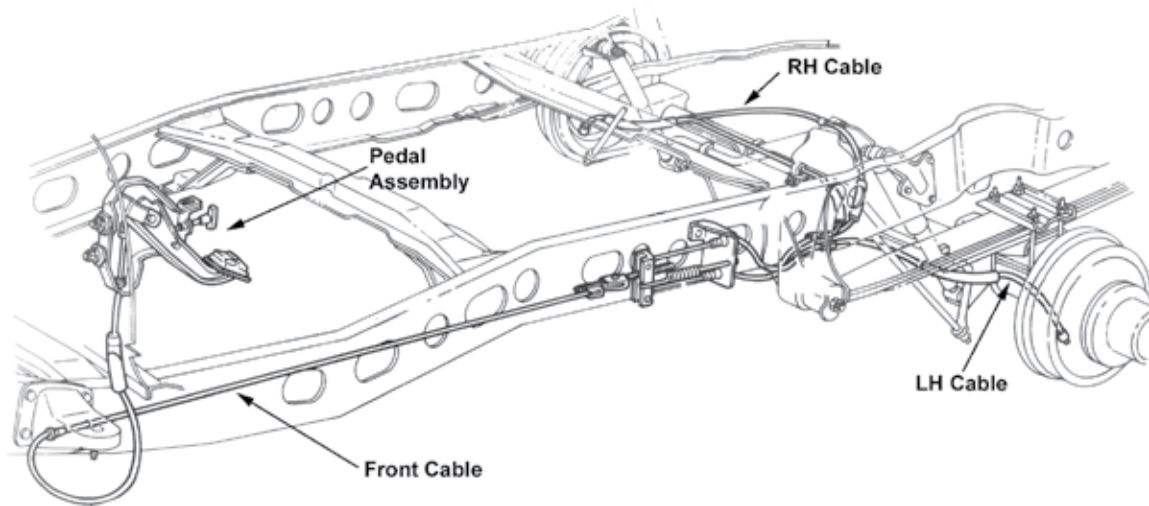

FRONT CABLES

BRONCO

2652	1980-83 Bronco Front Cable	\$20
32653	03\83-91 Bronco Front Cable	\$22
32654	1992-96 Bronco Front Cable	\$21

F-150

42620	1980-83 F-150 W/116"WB	\$22
42623	1984-91 F-150 W/116"WB	\$23

F-150 CONTINUED

42621	1980-83 F-150 W/138"WB	\$28
42622	1980-83 F-150 W/155"WB	\$22
42625	1984-91 F-150 W/138"WB	\$23
42625A	1984-91 F-150 W/155"WB	\$22
42625B	92-96 F-150 W/133" or 136"WB	\$22

RH CABLES

BRONCO

32655	1980-83 RH Cable	\$22
32656	1984-91 RH Cable	\$23
32657	1992-96 RH Cable	\$21

F-150

42626	1980-83 RH Cable	\$23
42627	1984-91 RH Cable	\$30
42628	1992-96 RH Cable	\$22

LH CABLES

BRONCO

32658	1980-86 LH Cable	\$20
32659	1987-91 LH Cable	\$20
32660	1992-96 LH Cable	\$20

F-150

42629	1980-83 F-150 LH Cable	\$23
42630	1984-02\87 F-150 LH Cable	\$23
42631	03\87-91 F-150 LH Cable	\$20
42632	1992-96 F-150 LH Cable	\$22

Please call or visit www.broncograveyard.com for F-250 and F-350 applications.

STEERING

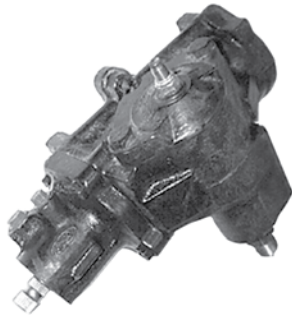

POWER STEERING GEAR

32800	Rebuilt Power Steering Box*	\$190
32805	Power Steering Box Seal Kit	\$29
32806	Power Steering Box Master Repair Kit	\$60
32804	80-96 Pitman Arm, Stock	\$52

**Item # 32802 Core charge (\$100) will be applied until rebuildable core is returned to us.*

POWER STEERING PUMP

32810	Rebuilt Power Steering Pump 1980-86	\$85
32811	Rebuilt Power Steering Pump 1987-91	\$85
32812	Power Steering Pump Reservoir	\$19
32808	Power Steering Pump Dipstick	\$7



POWER STEERING PRESSURE HOSES

Constructed with special high temperature, high pressure Hypalon hose. These aftermarket hoses offer superior performance and easy installation. Designed for use on all Bronco & F-Series trucks.

32820	1980-86 W/4.9L,5.0L,5.8L; 1987-89 W/5.8L	\$25
32821	1987 W/4.9L,5.0L; 1988-89 4.9LW/Auto Trans. & All 5.0L	\$35
32822	1988-89 All W/4.9L & Manual Transmission	\$25
32823	1990-93 All W/4.9L	\$32
32824	1990-91 All 5.0L Up to 3/6/91 Automatic or Manual	\$30
32825	1990-92 All 5.8L	\$32
32826	1991-92 W/5.0L & AOD After 3/6/91	\$38
32827	1991-92 W/5.0L E4OD After 3/6/91; 1993 5.8L	\$27
32828	1993 W/5.0L & AOD or Manual Trans	\$26
32829	1994 5.0L or 5.8L Auto;1995-96 All	\$25

OEM STEERING SHAFT

32850	Lower Steering Shaft, 88-91Bronco/Pick-up	\$269
32842	Rag Joint, 88-91 Bronco/Pick-up	\$35



HEAVY DUTY STEERING SHAFT

Truck steering systems take a lot of abuse and the stock steering shaft usually isn't up to the task. A factory steering shaft joint can wear out in as little as 4000 miles. Now is the time to replace it with one of these heavy duty shafts.

32850	88-91, Lower Shaft, W/Rag & U-Joints	\$299
32852	92-96, Stock Steering Coupler	\$65
32853	92-96, Intermediate Steering Shaft	\$119
32855	80-87, Borgeson Lower Steering Shaft	\$249
32856	80-91, Borgeson Shaft W/Dampener	\$275
32857	92-96 Borgeson Shaft, Double U-Joint	\$299

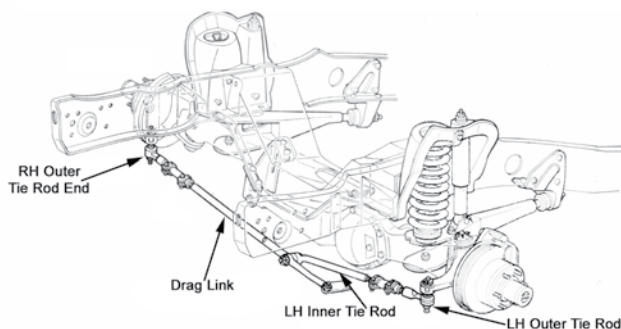
**STEERING RODS**

Worn out steering components not only hinder performance, but are also potentially dangerous. Replace your worn steering rods with these quality components from Jeff's Bronco Graveyard. Replace an individual piece or go with the whole steering rod kit. **Rod kit includes:** (1) RH tie rod, (1) draglink, (1) LH inner tie rod, (1) LH outer tie rod, (2) connecting sleeves.

STEERING ROD KITS

32715	1980-96 Bronco/F-150 4X4	\$139
32717	1980-96 F-100/F-150 2WD	\$139
32905	1980-84 F-250/350 4X4	\$160
32915	1985-97 F-250 4X4	\$229
32929	1986-98 F-350 4X4	\$329

DRAG LINK

32700	1980-96 Bronco/F-150 4X4	\$40
32701	1980-96 F-100/F-150 2WD	\$40
32900	1980-84 F-250/350 4X4	\$49
32910	1985-97 F-250 4X4	\$65

LH INNER TIE ROD END

32702	1980-96 Bronco/F-150 4X4	\$30
32903	1980-84 F-250/350 4X4	\$30
32913	1985-97 F-250 4X4	\$39
32922	1986-98 F-350 4X4	\$49

LH OUTER TIE ROD END

32706	1980-96 Bronco/F-150 4X4	\$20
32904	1980-84 F-250/350 4X4	\$25
32914	1985-97 F-250 4X4	\$25
32924	1986-98 F-350 4X4	\$25

RH OUTER TIE ROD END

32704	1980-96 Bronco/F-150 4X4	\$20
32901	1980-84 F-250/350 4X4	\$25
32911	1985-97 F-250 4X4	\$29
32928	1986-98 F-350 4X4	\$59

CONNECTING SLEEVES

32708	1980-96 Bronco/F-150, RH	\$15
32710	1980-96 Bronco/F-150, LH	\$15
32902	1980-96 F-250/350	\$18



tie rod dust boots

DAYSTAR POLYURETHANE TIE ROD DUST BOOTS

Torn or missing dust boots can lead to premature steering component failure. Keep your ride color coordinated while keeping water, dirt and other contaminants out of your steering rods. Available in black or red. Set of 4.

32730	Tie Rod Dust Boots (black)	\$6
32732	Tie Rod Dust Boots (red)	\$6

SUPERLIFT SUPERRUNNER STEERING

Replace your inferior stock twin traction beam steering components with Superlifts industry award winning Superrunner steering system. Enhance your lifted vehicles driveability by addressing these critical factors: drag link/tie rod angles, camber/caster settings, steering wheel center, and turning radius. All tie rod and drag link ends are greasable to extend service life.



32745	1980-96 Bronco/F-150	\$449
32980	1980-01/85 F-250	\$449
32981	02/85-1997 F-250	\$449



Don't forget to check us out on the web at
www.broncograveyard.com
 with secure on-line ordering, features, specials
 and more!!!

POLYURETHANE

BY ENERGY SUSPENSION®

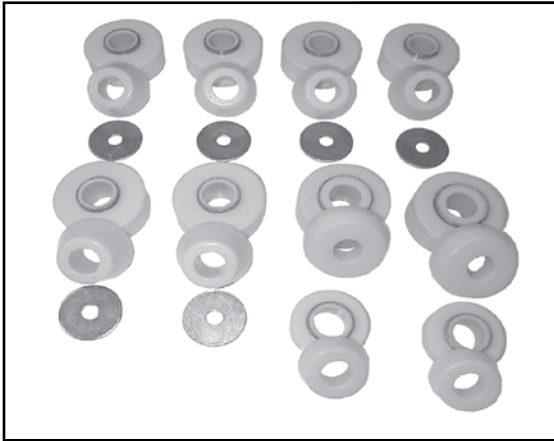

BODY MOUNTS

80-96 PICKUP

33095	Body Mount Bushings (black)	\$59
33097	Body Mount Bushings (red)	\$59

80-96 BRONCO

33090	Body Mount Bushings (black)	\$85
33092	Body Mount Bushings (red)	\$85

BODY MOUNT HARDWARE

OE style body mount hardware for your Bronco or Truck. Purchase the entire kit (includes all sleeves & bolts) or individually by position number (starting at front of vehicle).

33088	OEM Rubber Body Mt. Upper and Lower	\$5
33100	80-96 Body Mount Hardware, Bronco	\$389
33101	80-96 Body Mount Hardware, Pickup	\$279
33102	Core Support, Upper	\$30
33103	Core Support, Lower	\$13
33104	Body Mount Sleeve, Upper Position #2	\$29
33105	Body Mount Sleeve, Lower Position #2 or 3	\$19
33106	Body Mount Sleeve, Upper Position #3	\$30
33107	Body Mount Sleeve, Upper Position #4 or 5	\$22
33108	Body Mount Sleeve, Lower Position #4 or 5	\$20

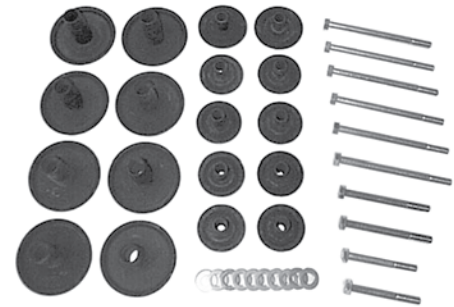

core support "Frame Saver" brackets

FRAME SAVER FRAME REPAIR

Repair rusted body mount locations on your frame with these weld-in hole reinforcement brackets.

33108A	Core Support Frame Saver	\$8
33108B	Position #2 Frame Saver	\$8
33108C	Position #3 Frame Saver	\$8
33108D	Position #4 or #5 Frame Saver	\$7
33108G	Complete Set of Frame Savers, Bronco	\$32
33108T	Complete Set of Frame Savers, Truck	\$20

RADIUS ARM BUSHINGS

33000	Radius Arm Bushings (black) 1980-91 Bronco, PU	\$18
33002	Radius Arm Bushings (red) 1980-91 Bronco, PU	\$18
33010	Radius Arm Bushings (black) 1992-96 Bronco, PU	\$18
33012	Radius Arm Bushings (red) 1992-96 Bronco, PU	\$18
33014	Set of 4, W/Washers & Bushings, 1980-84	\$22
33015	Set of 4, W/Washers & Bushings, 1985-96	\$24

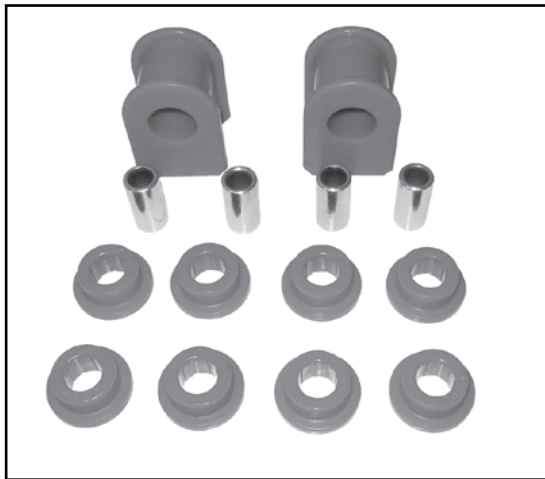

FRONT SWAY BAR BUSHING SETS

7/8" DIA. SWAY BAR

33109	Front Sway Bar Bushing Set (black)	\$20
33113	Front Sway Bar Bushing Set (red)	\$20

1" DIA. SWAY BAR

33110	Front Sway Bar Bushing Set (black)	\$20
33114	Front Sway Bar Bushing Set (red)	\$20

REAR SWAY BAR BUSHING SETS

7/8" DIA. SWAY BAR

33119	Rear Sway Bar Bushing Set (black)	\$20
33123	Rear Sway Bar Bushing Set (red)	\$20

1" DIA. SWAY BAR

33120	Rear Sway Bar Bushing Set (black)	\$20
33124	Rear Sway Bar Bushing Set (red)	\$20



REAR SWAY BAR END LINKS

33046	End Link Bushings (black)	\$5
33048	End Link Bushings (red)	\$5

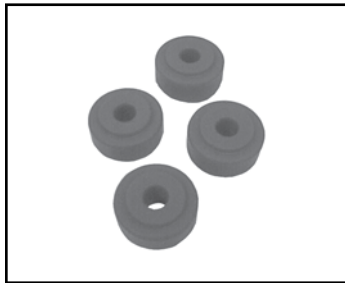

STEERING STABILIZER BUSHINGS

33040	Steering Stabilizer Bushings (black)	\$5
33044	Steering Stabilizer Bushings (red)	\$5

REAR SPRING BUSHING SET (COMMON STYLE)

Feel the difference these polyurethane leaf spring bushings make, while allowing the suspension to function more effectively. Set includes front and rear spring eye bushings and shackle bushings.

33050	1980-96 Bronco/F150 (black)	\$37
33054	1980-96 Bronco/F150 (red)	\$37



IDENTIFYING YOUR SPRING BUSHINGS

Ford used 2 different style spring bushings in their 1980-96 Trucks. The "Common Style" with a metal shell around the bushing and a "Molde-In" style without the metal jacket. Please use the provided illustration to help you determine which style you have.

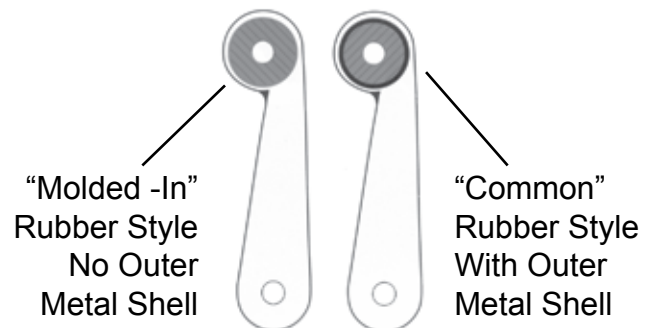

REAR SPRING BUSHING SET (W/MOLDED IN FRAME SHACKLE BUSHING)

Similar to the bushings above but designed to work with the far less common "molded in frame" shackle bushing.

33156	1980-96 Bronco/F150 (black)	\$40
33158	1980-96 Bronco/F150 (red)	\$40

REAR SHACKLE BUSHING (COMMON BUSHING)

Common shackle bushings will have a thin metal outer shell incorporated around the bushing, separate from the shackle itself. These are the most common style bushing.

- | | | |
|-------|-----------------------------------|------|
| 33055 | 1980-96 Bronco/F150, Pair (black) | \$14 |
| 33056 | 1980-96 Bronco/F150, Pair (red) | \$14 |

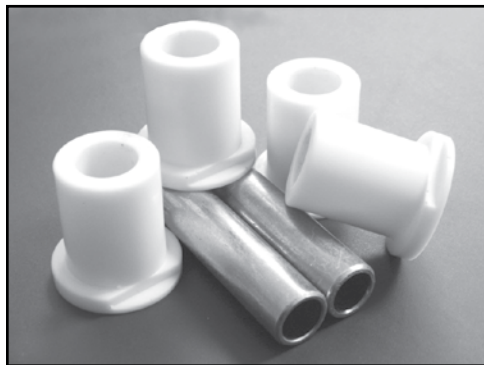

REAR SHACKLE BUSHING (MOLDED IN FRAME STYLE BUSHING)

These shackle bushings are replacements for bushings that were molded into the shackle without a thin metal shell (see above). This is the least common style of shackle bushing.

- | | | |
|-------|-----------------------------------|------|
| 33160 | 1980-96 Bronco/F150, Pair (black) | \$14 |
| 33161 | 1980-96 Bronco/F150, Pair (red) | \$14 |

FRONT SPRING EYE BUSHING

- | | | |
|-------|--------------------------|------|
| 33170 | 1980-96 F250/350 (black) | \$45 |
| 33172 | 1980-96 F250/350 (red) | \$45 |



**AXLE PIVOT BUSHINGS****4 WHEEL DRIVE**

33140	1980-96 Bronco/F150 (black)	\$23
33144	1980-96 Bronco/F150 (red)	\$23

2 WHEEL DRIVE

33150	1980-96 Bronco/F150, W/Cast Axle (black)	\$23
33151	1981-83 Bronco/F150, W/Stamped Axle (black)	\$23
33153	1980-96 Bronco/F150, W/Cast Axle (black)	\$23
33154	1987-96 F150/250, W/Cast Axle (black)	\$23

BULLET STYLE FRONT BUMPSTOPS

The compact bullet design of these bumpstops is perfect for getting clearance around front radius arms. Proven at the track and on the street (sold in pairs).

33060	2" Bullet Style Bumpstops (black)	\$10
33064	2" Bullet Style Bumpstops (red)	\$10

**STUD MOUNTED BUMPSTOPS**

These superior polyurethane bumpstops are manufactured with a reinforced metal plate for strength. Polyurethane lasts longer and operates more efficiently than OEM rubber stops. Stud mount.

23110	Stud Mount Bumpstops 2½" (black)	\$35
23112	Stud Mount Bumpstops 2½" (red)	\$35
23115	Stud Mount Bumpstops 4½" (black)	\$45
23117	Stud Mount Bumpstops 4½" (red)	\$45

BOLT ON BUMPSTOPS

Help cushion a collapsing suspension and prevent expensive damage with these slotted bolt-on polyurethane bumpstops.

13085	3" Bolt-on Bumpstops (black)	\$35
13087	3" Bolt-on Bumpstops (red)	\$35
13090	4½" Bolt-on Bumpstops (black)	\$45
13092	4½" Bolt-on Bumpstops (red)	\$45



TIE ROD DUST BOOTS

33130	Dust Boot Set 4pc. (black)	\$5
33134	Dust Boot Set 4pc. (red)	\$5

FRONT SHOCK BUSHINGS

33020	Front Shock Bushings (black)	\$5
33024	Front Shock Bushings (red)	\$5

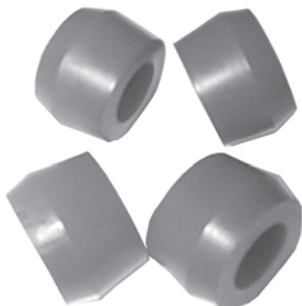
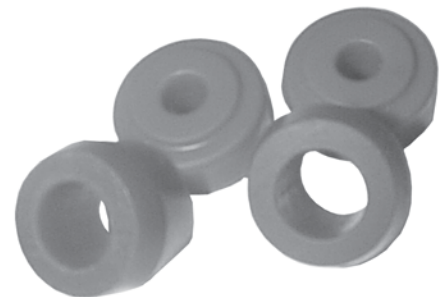

REAR SHOCK BUSHINGS

33030	Rear Shock Bushings (black)	\$5
33034	Rear Shock Bushings (red)	\$5

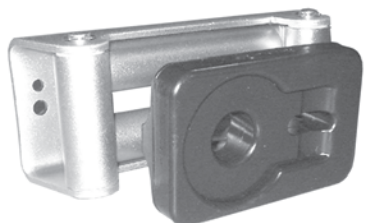
**WINCH FAIRLEAD ISOLATOR.**

The winch fairlead isolator helps isolate your winch hook from the fairlead preventing possible damage.

13190 Winch Fairlead Isolator \$29

HIGH LIFT JACK ISOLATOR

The high lift jack isolator wraps around your high lift jack to keep it from rattling. It also provides a convenient storage space for your jack handle.

19650 High Lift Jack Isolator \$12

**EVS FOAM SHOCK BUMPSTOPS**

Daystar has developed a new line of foam shock bump stops (EVS) designed to install on any aftermarket or OE shock. These foam isolators will enhance shock performance by softening your shocks compression preventing hard impact at bottoming. Available in 2 different foam densities, Black (stiff), and Red (soft) to better match your performance requirements.

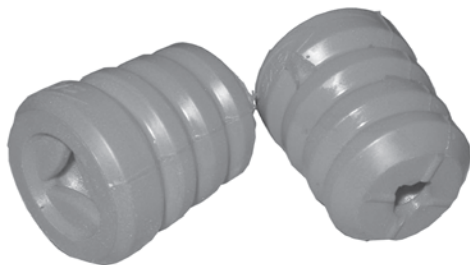

13125	EVS Foam Shock Bumpstop (stiff)	\$18
13127	EVS Foam Shock Bumpstop (soft)	\$18
13129	EVS Foam Shock Bumpstop Install Tool	\$9

SUSPENSION



FRONT COIL SPRINGS

These coil springs are offered in a variety of sizes and offer excellent ride quality, control and longevity. Available for 1980-96 Bronco/Pick-ups and 1980-96 extended cab pick-ups (sold in pairs).

33200	1980-96 Bronco/Pick-up Stock Height	\$80
33201	1980-96 Extended Cab Pick-up Stock Height	\$90
33202	1980-96 Std. Cab Pick-up Heavy Duty	\$90
33500	1980-96 Bronco/Pick-up 1½"-2" Lift	\$135
33501	1980-96 Extended Cab Pick-up 1½"-2" Lift	\$135
33502	1980-96 Bronco/Pick-up 4" Lift	\$129
33504	1980-96 Bronco/Pick-up 6" Lift	\$129

COIL SPRING TOWER*

33205	80-96 Coil Spring Tower, RH W/Single Shock	\$90
33207	80-96 Coil Spring Tower, LH W/Single Shock	\$105
33210	80-96 Coil Spring Tower, RH W/Double Shock	\$100
33212	80-96 Coil Spring Tower, LH W/Double Shock	\$135



hex spacer



upper retainer



spring mounting stud

COIL SPRING HARDWARE

33535	¼" Coil Spring Spacers Hex (pair)	\$12
33537	¼" Coil Spring Spacers Round (pair)	\$12
33224	Upper Coil Spring Retainer	\$10
33225	Lower Spring Mounting Stud	\$18

BRONCO/F-150 LEAF SPRINGS

33545	F150, 2WD, Rear Leaf Springs, 80-96	\$205
33548	Bronco/F150 Rear Leaf Springs Stock (pair)	\$205
33550	Bronco/F150 Rear Leaf 2½" Lift (pair)	\$295
33551	Bronco/F150 Rear Leaf 4½" Lift (pair)	\$295
33554	Bronco/F150 Rear Leaf 6" Lift (pair)	\$420
33259	Hardware Kit 80-96 Bronco/Pickup	\$24



stock leaf spring

F-250/350 FRONT LEAF SPRINGS

33242	80-97 4X4 Std Height (pair)	\$215
33244	80-97 4X4 Std Height (pair)	\$250
33246	80-97 4X4 Std Height (pair)	\$295
33562	80-97 4X4 4" Lift (pair)	\$415
33563	80-97 4X4 4" Lift Powerstroke (pair)	\$439
33564	80-97 4X4 6" Lift (pair)	\$419
33565	80-97 4X4 6" Lift Powerstroke (pair)	\$449

**F-250/350 REAR LEAF SPRINGS**

33252	80-96 F250, 2450lb (pair)	\$225
33254	80-96 F250/350, 2977lb (pair)	\$299
33566	80-96 F250/350, 3" Lift* (pair)	\$389
33568	80-96 F250/350, 5" Lift* (pair)	\$389

*Spring eye bushings sold separately

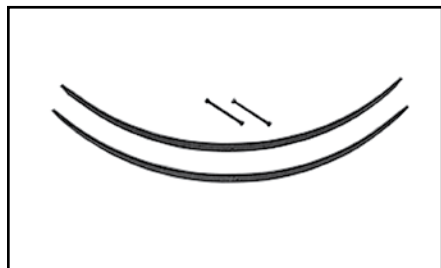
**ADD-A-LEAF KITS**

If your looking to beef up your stock springs or add some lift to your truck, these add-a-leaf kits will do the trick

33578	2"-3" Rear Add-A-Leaf, Long (pair)*	\$75
33579	2"-3" Rear Add A Leaf, Short (pair)*	\$91
33577	3-3½" Front Add-A-Leaf, Long (pair)	\$89

* Amount of lift will vary depending on style and weight of vehicle.

REAR SWAY BAR DROP LINK

33272	80-96 Bronco Rear Sway Bar Drop Link	\$25
33273	80-96 Truck Rear Sway Bar Drop Link	\$32
33660	80-96 Front Sway Bar Drop Brackets	\$49



FRONT SPRING HANGER

33260	Front Spring Hanger, 1980-96 Bronco	\$45
33261	Front Spring Hanger, 1980-96 F150/250 4X4	\$45
33261A	Front Spring Hanger, 1980-96 F350	\$40

REAR SPRING HANGER

33262	80-96 Bronco/Truck W/3" Springs	\$69
332621	80-96 Bronco/Truck W/3" Springs (aftermarket)	\$33
33262A	80-96 2WD Truck W/2½" Springs	\$32
332622	80-96 2WD Truck W/2½" Springs (aftermarket)	\$24

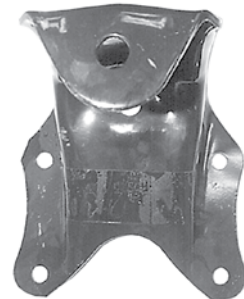

SPRING SHACKLE

33263A	80-96 Bronco/Truck W/3" Springs (aftermarket)	\$18
33264	80-96 Bronco/Truck W/3" Springs (OEM)	\$41
33264A	80-96 Truck W/2½" Springs (OEM)	\$31
33264B	80-96 Truck W/2½" Springs (aftermarket)	\$17
33269	80-97 F250/350, Front Shackle	\$149
33269A	80-97 F250/350, Front Shackle (aftermarket)	\$33

SPRING HARDWARE

33259	Bolt Kit, 80-96 Bronco/Truck W/3" Spring	\$24.95
33580	Leaf Spring Bend Clips For 2½" Spring (set of 4)	\$9
33582	Leaf Spring Bend Clips For 3" Spring (set of 4)	\$9
33585	Leaf Spring Center Bolt, Pair	\$5



80-96 SPRING HANGER REPAIR

33265	Rear Hanger Repair Kit For 3" Spring (OEM)	\$53
33265A	Rear Hanger Repair Kit For 2½" Spring (OEM)	\$50
33261B	Front Spring Hanger Kit, F150/250, 4X4 (Aft)	\$35
33262B	Rear Spring Hanger Kit, W/3" Spring (Aft)	\$29
33263	Rear Spring Shackle Kit (Aft)	\$25

**SHOCK MOUNT**

33285	Rear Upper Shock Mount	\$15
33214	85-93 F-250 Upper Front Shock Bracket	\$23
33215	94-96 F-250 Upper Front Shock Bracket	\$40
13632	Lower Rear Shock Mounts	\$17

U-BOLTS & RELATED PARTS

33282	U-Bolts, Bronco/Truck, 8½"	\$28
33282PU	U-Bolts, Bronco/Truck, 10"	\$28
23282B	U-Bolts, Bronco/Truck, 12"	\$34
23282C	U-Bolts, Bronco/Truck, 14"	\$34
23282D	U-Bolts, Bronco/Truck, 16"	\$39
33267	U-Bolt Retainer Plate For 3" Spring, OEM	\$52
33268	U-Bolt Retainer Plate For 3" Spring, Aftermarket	\$15
33268P	U-Bolt Retainer Plates For 3" Spring, Aftermarket (pair)	\$24
33258	80-96 Leaf Spring Perches	\$20

**REAR SPRING SHIM**

33570	Rear Spring Shims 4° (pair)	\$15
33572	Rear Spring Shims 6° (pair)	\$15

OEM REAR ANGLE BLOCKS

33266	Rear Angle Blocks (each)	\$50
-------	--------------------------	------

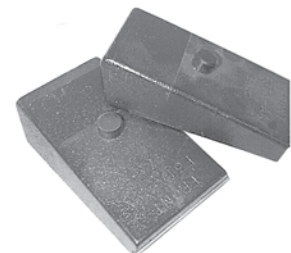



lift block kit

REAR SPRING BLOCK KITS

Manufactured by BDS, these block kits are tapered to address drive-shaft angle, length and adjustment. Each kit contains 2 blocks, 4 U-bolts and locknuts & washers. Note: Please remember block kits should not be used on the front of any vehicle.

BRONCO REAR BLOCK KITS

33300	1½" Rear Block Kit	\$60
33305	2" Rear Block Kit	\$65
33310	3" Rear Block Kit	\$69
33315	4" Rear Block Kit	\$75
33320	5" Rear Block Kit	\$75

F-150 REAR BLOCK KITS

33301	1½" Rear Block Kit	\$60
33306	2" Rear Block Kit	\$65
33311	3" Rear Block Kit	\$69
33316	4" Rear Block Kit	\$75
33321	5" Rear Block Kit	\$75

F-250 REAR BLOCK KITS

23315	1½" Block Kit	\$63
23325	2" Block Kit	\$65
23335	3" Block Kit	\$69
23345	4" Block Kit	\$75
23353	5" Block Kit	\$75

F-350 REAR BLOCK KITS

33304	1½" Block Kit	\$60
33309	2" Block Kit	\$65
33314	3" Block Kit	\$70
33319	4" Block Kit	\$75
33324	5" Block Kit	\$75



adjustable alignment bushing



drop pitman arm

MISCELLANEOUS LIFT COMPONENTS

33518	Drop Pitman Arm 80-96 W/4" or 6" Lift	\$69
33520	4X4 Adjustable Alignment Bushings (pair)	\$55
33522	83-86 2WD Adj. Alignment Bushings (pair)	\$55
33523	87-96 2WD Adj. Alignment Bushings (pair)	\$55

STAINLESS BRAIDED EXTENDED BRAKE LINES

33530	5" Extended Front Axle Lines 80-89 (pair)	\$75
33531	5" Extended Front Axle Lines 90-96 (pair)	\$75
33575	80-91 Extended Rear Line (stainless)	\$35
33576	92-96 Extended Rear Line (stainless)	\$38
52545	5" Extended Front, 80-97 F250/350	\$80



RADIUS ARMS

33231	2WD Radius Arm, RH or LH 89-96	\$85
33232	4WD RH Radius Arm, OEM 80-96 Bronco/PU	\$109
33233	4WD LH Radius Arm, OEM 80-96 Bronco/PU	\$109
33226	RH Radius Arm Bracket, 80-96 Bronco/PU	\$49
33228	LH Radius Arm Bracket, 80-96 Bronco/PU	\$49
33234	Radius Arm Nut	\$4

**BODY LIFTS BY PERFORMANCE ACCESSORIES**

33325	1980-86 Bronco 2"	\$99
33326	1980-86-Bronco 3"	\$109
33327	1980-86 Pick-up 2"	\$99
33328	1980-86 Pick-up 3"	\$125
33329	1987-91 Bronco 2"	\$159
33330	1987-91 Bronco 3"	\$109
33331	1987-91 Pick-up 2"	\$159
33332	1987-91 Pick-up 3"	\$129
33333	1992-96 Bronco 3"	\$139
33334	1992-96 Pick-up 3"	\$145
33337	Front Urethane Gap Guards	\$79
33338	Rear Urethane Gap Guards	\$27

**FABRITECH TRACTION CONTROL**

HD ladder bars connect at front with spherical rod ends and at rear with brackets. Stage II is mounted with polyurethane bushing front and rear. Standard length is 4 ft. but 5 ft. lengths are available for extended cabs, long beds, radical lifts etc . . . Your choice of red, yellow, black, silver, or chrome powder coat colors.



HD ladder bars



Stage II traction bars

HD 4' LADDER BARS

33600	4' HD Ladder Bars (red)	\$315
33601	4' HD Ladder Bars (yellow)	\$315
33602	4' HD Ladder Bars (black)	\$315

HD 5' LADDER BARS

33600A	5' HD Ladder Bars (red)	\$410
33601A	5' HD Ladder Bars (yellow)	\$410
33602A	5' HD Ladder Bars (black)	\$410

STAGE II TRACTION BARS

33605	Stage II Traction Bars (red)	\$330
33606	Stage II Traction Bars (yellow)	\$330
33607	Stage II Traction Bars (black)	\$330

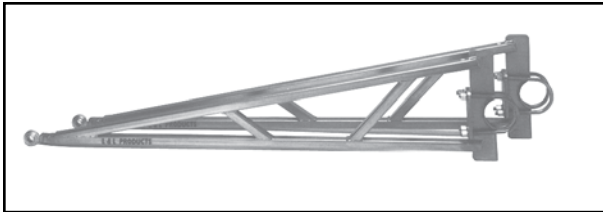

L&L PRODUCTS LADDER BARS.

These L&L ladder traction bars are made in the USA and are manufactured from 1" Dia. square tubing W/.130 wall thickness.

Features Include:

- 48" length bar with 3/4" spherical rod ends.
- Bolt on installation.
- Adjustable pre-load.
- Helps eliminate wheel hop and broken parts.

33650	Ladder Bars 9 Inch	\$299
33652	Ladder Bars Dana 60	\$299
33654	Ladder Bars Dana 70	\$299
33656	Mounting kit 80-96 Bronco	\$79
33658	Mounting Kit 80-96 Pick-up	\$79

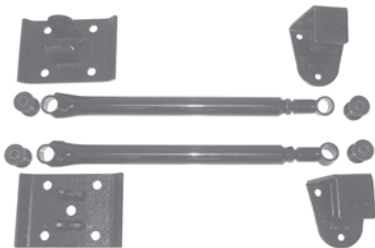

SUPERLIFT TRACTION BAR KIT

Traction bar kit features .250" steel plate brackets, 1.50" OD X .219" wall thickness tubing, and adjustable ends with 3/4 inch diameter threads, and slotted front mounting holes to help you control suspension wrap without sacrificing travel.

33640	Traction Bar Kit	\$239
-------	------------------	-------

JBG FRONT BRACKET KIT

Front axle pivot brackets made from 1/4" plate steel, while radius arm brackets are constructed of nodular iron. Part #33516 also includes the radius arms (below).

33515	80-96 JBG Front Brackets	\$289
33516	80-96 JBG Front Brackets W/Arms	\$529
33514	80-96 Front Axle Pivot Drop Brackets	\$155



bracket kit

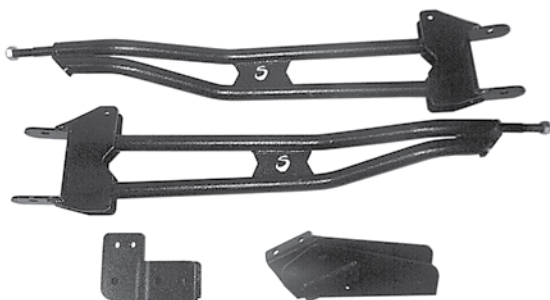

JBG EXTENDED RADIUS ARMS

These radius arms offer caster correction plus other benefits. The arms are longer than stock to increase the amount of usable bind-free extension travel. You'll experience a noticeable difference both on and off road. Kit includes brackets and attaching hardware.

33517	JBG Radius Arms	\$459
-------	-----------------	-------

LIFT KITS

FRONT END LEVELING KIT

Does your Bronco sit too low in the front? Give it the boost it needs with this 1½"-2" leveling kit. Kit includes front leveling coils and 2 adjustable alignment bushings.



33700	1½"-2" Leveling Kit 80-96 Bronco	\$189
33701	1½"-2" Leveling Kit 80-96 Pick-up	\$189
33700A	1½"-2" Leveling Kit 83-86 2WD	\$199
33700B	1½"-2" Leveling Kit 87-96 2WD	\$199

POLYURETHANE COIL SPRING SPACERS

2" polyurethane spacers available in black or red.

33190	80-96 2" Coil Spacer, Black	\$99
33192	80-96 2" Coil Spacer, Red	\$99

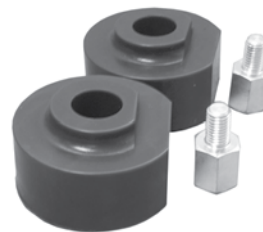

SPEED SENSOR CALIBRATOR

The Superlift TruSpeed calibrator doesn't just correct the speedometer, it corrects the signal so that all speed sensitive systems receive the correct speed data.

38050	TruSpeed Calibrator 92-96 W/Rear ABS	\$189
38051	TruSpeed Calibrator 94-96 W/4 Wheel ABS	\$189





JBG LIFT KITS

BY BDS SUSPENSION

Standard 4" kit includes: Front coils, front bracket kit, drop pitman arm, rear blocks and U-bolts.



STANDARD 4" LIFT KIT

33705	80-89 Bronco/F-150	\$495	33715	90-96 Bronco/F-150	\$495
33705A	80-89 F-150 2WD	\$475	33740	80-96 F-150 Super Cab	\$499

STANDARD 4" KIT RADIUS ARMS

33708	80-89 Bronco/F-150	\$779
33718	90-96 Bronco/F-150	\$779
33745	80-96 F-150 Super Cab	\$779



JBG LIFT KITS

BY BDS SUSPENSION

Deluxe 4" kit includes: New front coils, front bracket kit, rear add-a-leaf, rear block kit, Drop pitman arm, front & rear axle brake hoses.

DELUXE 4" LIFT KIT

33706	80-86 Bronco/F-150	\$689	33741	80-86 F-150 Super Cab	\$639
33706B	87-89 Bronco/F-150	\$689	33741A	87-89 F-150 Super Cab	\$639
33716	90-96 Bronco/F-150	\$689	33741B	90-96 F-150 Super Cab	\$639

DELUXE 4" KIT RADIUS ARMS

33709	80-86 Bronco/F-150	\$945	33746	80-86 F-150 Super Cab	\$945
33709A	87-89 Bronco/F-150	\$945	33746A	87-89 F-150 Super Cab	\$945
33719	90-96 Bronco/F-150	\$945	33746B	90-96 F-150 Super Cab	\$945



JBG LIFT KITS

BY BDS SUSPENSION

Ultra Deluxe 4" kit includes: New front coil springs, front bracket kit, drop pitman arm, front & rear hoses, rear leaves and U-bolts.



ULTRA DELUXE 4" KIT

33707	80-86 Bronco/F-150	\$879	33742	80-86 F-150 Super Cab	\$879
33707B	87-89 Bronco/F-150	\$879	33742A	87-89 F-150 Super Cab	\$879
33717	90-96 Bronco/F-150	\$879	33742B	90-96 F-150 Super Cab	\$879

ULTRA DELUXE 4" KIT RADIUS ARMS

33710	80-86 Bronco/F-150	\$1095	33747	80-86 F-150 Super Cab	\$1095
33710A	87-89 Bronco/F-150	\$1095	33747A	87-89 F-150 Super Cab	\$1095
33720	90-96 Bronco/F-150	\$1095	33747B	90-96 F-150 Super Cab	\$1095



JBG LIFT KITS

BY BDS SUSPENSION

Standard 6" kit includes: New front coils, front bracket kit, drop pitman arm, rear blocks and U-bolts.

STANDARD 6" KIT

33805	80-89 Bronco/F-150	\$515	33840	80-96 F-150 Super Cab	\$515
33815	90-96 Bronco/F-150	\$515			

STANDARD 6" KIT RADIUS ARMS

33808	80-89 Bronco/F-150	\$875	33845	80-96 F-150 Super Cab	\$879
33818	90-96 Bronco/F-150	\$875			



JBG LIFT KITS

BY BDS SUSPENSION

Deluxe 6" kit includes: New front coils, front bracket kit, rear add-a-leaf, rear blocks, drop pitman arm and front & rear axle brake hoses.



DELUXE 6" KIT

33806	80-86 Bronco/F-150	\$739	33841	80-86 F-150 Super Cab	\$739
33806A	87-89 Bronco/F-150	\$739	33841A	87-89 F-150 Super Cab	\$739
33816	90-96 Bronco/F-150	\$739	33841B	90-96 F-150 Super Cab	\$739

DELUXE 6" KIT RADIUS ARMS

33809	80-86 Bronco/F-150	\$985	33846	80-86 F-150 Super Cab	\$985
33809A	87-89 Bronco/F-150	\$985	33846A	87-89 F-150 Super Cab	\$985
33819	90-96 Bronco/F-150	\$985	33846B	90-96 F-150 Super Cab	\$985



JBG LIFT KITS

BY BDS SUSPENSION

Ultra Deluxe 6" kit includes: New front coils, front bracket kit drop pitman arm, front & rear brake hoses, rear leaf springs and U-Bolts.

ULTRA DELUXE 6" KIT

33807	80-86 Bronco/F-150	\$935	33842	80-86 F-150 Super Cab	\$935
33807A	87-89 Bronco/F-150	\$935	33842A	87-89 F-150 Super Cab	\$935
33817	90-96 Bronco/F-150	\$935	33842B	90-96 F-150 Super Cab	\$935

ULTRA DELUXE 6" KIT RADIUS ARMS

33810	80-86 Bronco/F-150	\$1145	33847	80-86 F-150 Super Cab	\$1145
33810A	87-89 Bronco/F-150	\$1145	33847A	87-89 F-150 Super Cab	\$1145
33820	90-96 Bronco/F-150	\$1145	33847B	90-96 F-150 Super Cab	\$1145

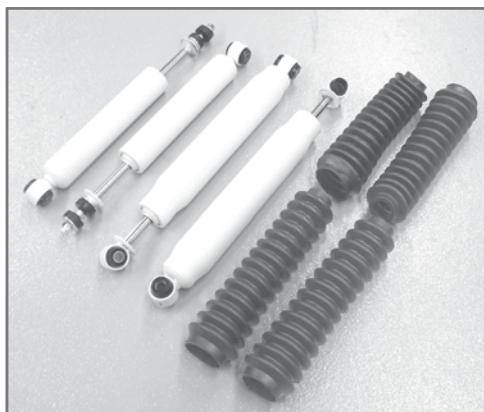

LIFT KIT SHOCK OPTIONS

Purchasing a JBG lift kit? We make it convenient to add shocks to your set-up. **4 shock option includes:** 2 front shocks, 2 rear shocks and 4 boots. **6 shock option includes:** 4 front shocks, 2 rear shocks and 6 boots.

33748	4" Lift 4 Shock Option	\$123
33749	4" Lift 6 Shock Option	\$183
33848	6" Lift 4 Shock Option	\$123
33849	6" Lift 6 Shock option	\$183

F-250/350 Lift Kits



Standard kit includes: Front springs, drop pitman arm, rear add-a-leaf/rear block kit, spring eye bushings, U-Bolts, pivot brackets and 4 shocks W/boots.

Ultra kit: Same as above but substitutes rear springs for add-a-leaf/block kit.



4" F-250 KITS

33770	Std. Kit 80-86 (gas)	\$959
33774	Std. Kit 87-97 (diesel)	\$969
33776	Ultra Kit 80-86 (gas)	\$1355
33778	Ultra Kit 87-97 (gas)	\$1355
33780	Ultra Kit 87-97 (diesel)	\$1365

4" F-350 KITS

33784	Std. Kit 80-85 W/IFS (gas)	\$959
33786	Std. Kit 86-97 Monobeam (gas)	\$849
33788	Std. Kit 86-97 Monobeam (diesel)	\$849
33790	Ultra 80-85 W/IFS (gas)	\$1355
33792	Ultra 86-97 Monobeam (gas)	\$1259
33794	Ultra 86-97 Monobeam (diesel)	\$1299

6" F-250 KITS (INCLUDES SUPERRUNNER STEERING KIT).

33850	Std. Kit 80-85 F250 (gas)	\$1635	33860	Ultra 80-85 F250 (gas)	\$2055
33852	Std. Kit 2/85-86 F250 (gas)	\$1635	33862	Ultra 2/85-86 F250 (gas)	\$2055
33854	Std. Kit 87-97 F250 (diesel)	\$1635	33864	Ultra 87-97 F250 (gas)	\$2055
33855	Std. Kit 85-97 F250 (diesel)	\$1675	33866	Ultra 87-97 F250 (diesel)	\$2095

ARTICULATING SUSPENSION

SUPERFLEX FRONT COIL SPRINGS

Premium 5½" lift SuperFlex front coil springs. These variable rate coil springs offer you the ultimate in ride quality and flexibility.

33510 5½" SuperFlex Front Coil Springs \$160



SUPERFLEX REAR LEAF SPRINGS

Deavers 10 leaf pack units feature full military-wrapped spring eyes, anti-friction pads, rebound clips and urethane compression travel stops. A thinner leaf material allows for the use of more leafs. More leafs yields a more flexible leaf stack. The even, compression rate curve is the key to excellent ride quality.

33555 4" SuperFlex Rear Leaf Springs \$549



5½" STANDARDFLEX LIFT KIT

Step up to the StandardFlex suspension kit for your Bronco or Pickup. StandardFlex kit includes: JBG exclusive SuperFlex (pre-runner) front coils, Superlift rear blocks, Superlift drop bracket kit, Superlift drop pitman arm, Superlift adjustable alignment bushings and extended front and rear brake hoses.

33880 80-89 Bronco/F150 5½" Kit \$735
 33881 87-89 Bronco/F150 5½" Kit \$735
 33882 90-96 Bronco/F150 5½" Kit \$735





5½" STANDARDFLEX LIFT KIT W/RADIUS ARMS

Includes everything from our great 5½" StandardFlex kit and adds a set of Superlift extended radius arms for an even higher level of performance.

33880A	80-86 Bronco/F150 5½" Kit W/Arms	\$1029
33881A	87-89 Bronco/F150 5½" Kit W/Arms	\$1029
33882A	90-96 Bronco/F150 5½" Kit W/Arms	\$1029

5½" SUPERFLEX LIFT KIT

The JBG 5½" Superflex kit is the next level of Articulating flex suspensions. This awesome kit includes: JBG exclusive SuperFlex (prerunner) front coils, JBG exclusive SuperFlex (prerunner) rear leaf springs, Superlift drop bracket kit, Superlift drop pitman arm, Superlift adjustable alignment bushings and extended front and rear brake hoses.

33884	80-86 Bronco/F150 5½" Kit	\$1149
33885	87-89 Bronco/F150 5½" Kit	\$1149
33886	90-96 Bronco/F150 5½" Kit	\$1149



5½" SUPERFLEX LIFT KIT W/RADIUS ARMS

The ultimate in articulating flex suspensions! This JBG lift kit includes everything from our regular ½" Superflex lift kit, but also includes a set of Superlift extended radius arms.

33884A	80-86 Bronco/F150 5½" Kit W/Arms	\$1549
33885A	87-89 Bronco/F150 5½" Kit W/Arms	\$1549
33886A	90-96 Bronco/F150 5½" Kit W/Arms	\$1549



The following chart is designed to give you an **idea** of what size tires you can fit on your truck after installing one of our lift kits. It also shows what other modifications, if any, may be necessary. **Note: This chart is only an approximation and was prepared with standard width tires in mind.**

MODEL	YEAR	MODIFICATION	Tire Diameter									
			31	32	33	34	35	36	38	40	42	
BRONCO	66-77	NONE	3½	5½								
		CUT-OUT FLARE			3½		5½					
		3" BODY LIFT					3½	5½				
	78-79	NONE			1½	4		6½				
		FENDER TRIM				1½	4		6½			
		3" BODY LIFT					1½	4		6½		
	80-96	NONE		2	4		6					
		FENDER TRIM			2	4		6				
		3" BODY LIFT				2	4		6			
F-100/150	66-79	NONE			1½	4		6½	9			
		FENDER TRIM				1½	4		6½	9		
		3" BODY LIFT					1½	4		6½	9	
	80-96	NONE		2	4		6					
		FENDER TRIM			2	4		6				
		3" BODY LIFT				2	4		6			
	97-98	NONE			2	4	5					
		3" BODY LIFT				2	4	5				
	F-250	77½-79	NONE					4				
FENDER TRIM								4				
3" BODY LIFT									4			
80-97		NONE					4	6				
		FENDER TRIM						4	6			
		3" BODY LIFT							4	6		
99		NONE					2	4	6			
		FENDER TRIM							4	6		
F-350	80-97	NONE					4					
		FENDER TRIM						4				
		3" BODY LIFT							4			
	99	NONE					2	4	6			
		FENDER TRIM							4	6		

STRAIGHT AXLE CONVERSION



FABRITECH
Ford Straight Axle
Conversion

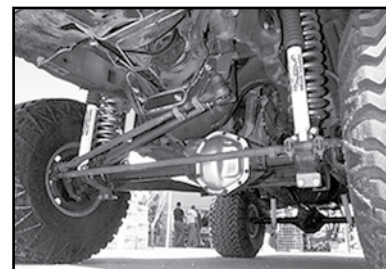

Finally!!! A remedy for the tire eating, impossible to align Twin Traction Beam front suspension setup used on all Ford trucks from 1980-96. This kit completely replaces the Twin Traction Beam setup with a coil spring 73-79 straight front axle using new brackets and components. This axle conversion provides greater ground clearance, improved ride handling and drivability, and overall better suspension performance. The kit uses any pre-1980 full size Dana 44 or you can convert a Dana 60 by installing C- bushing tabs which are available from us. This is a complete bolt on application, with no welding required. The bracketry uses existing factory holes to simplify installation and provide a template for drilling the 11 new holes that are required. Available for 1980-96 F-Series, & Broncos with 6"-10" of lift. The conversion uses the IFS type coil spring with a center mounting stud that yields 2" of additional lift. **For example:** If you already have a 6" lift and you purchase the 8" conversion you will not need to purchase new coil springs. The Stage II kit is offered with a 6" leaf spring used in combination with a block kit to achieve the needed amount of lift. All components must be purchased in one of the available packages.

STAGE I KITS

This is the basic suspension bracket kit. **The kit includes:** Extended custom radius arms (relieved for larger tires), coil support mounting blocks, drop radius arm mounting brackets, reinforced adjustable trac-bar, drop trac-bar bracket and template, cross member, drop pitman arm, adjustable drag link, custom tie rod set, bushings and mounting hardware.

33905	6" Conversion Kit	\$1899	33920	10" Conversion Kit	\$1899
33910	8" Conversion Kit	\$1899			

STAGE II KITS.

The stage II kit includes everything in the Stage I kit plus all of the additional suspension components from a traditional suspension kit. **Kit includes:** Front coils, rear leaf springs, block kit, brake hoses Etc... Pricing for this kit varies according to which options are chosen.

Approximately \$3000. Please call to discuss specific pricing and options available for your application.

STAGE III KITS.

The Stage III package includes everything in the Stage II kit plus a complete Dana 44 front end rebuilt to your specifications. Obviously, pricing for this kit is based on which options you choose for your front end.

Approximately \$4500+. Please call to discuss specific pricing and options available for your application.

SHOCKS



DOETSCH TECH SHOCKS

Pre-runner™ 8000 series shocks from Doetsch-Tech. Designed from many years of off-road racing, the Pre-runner incorporates many hours of testing at actual off-road racing events, such as the Baja 1000. The Pre-runner™ is extremely effective on and off road. Features include massive 1-5/8" piston assembly, large 11/16" chrome shaft, and high velocity speed sensitive valving. Double welded construction. Limited lifetime warranty. When ordering, please specify year, amount of lift, single or double shocks, front or rear, running length etc.

33400 Doetsch Tech Pre-Runner Shock \$44

JBG SHOCKS by BDS

JBG shocks with Correct Application Valving Technology which results in increased load stability, longer front end and tire life, less nose dive when braking, less squat on acceleration and a smoother ride. JBG shocks feature double wall construction, 1-3/8" Dia. Piston with glass filled Teflon seal and ten stage velocity sensitive valving. When ordering, please specify year, amount of lift, single or double shocks, front or rear etc. . .



23440 JBG Shock \$32

SHOCK BOOTS

Protect your investment with our shock boots. These shock boots will help seal out harmful debris and provide protection from shaft pitting to help extend seal life. Specify your choice of black, blue, red, or yellow.



33499 Shock Boot (Black)	\$3	33499R Shock Boot (Red)	\$3
33499B Shock Boot (Blue)	\$3	23499Y Shock Boot (Yellow)	\$3

STEERING STABILIZER

Adding a steering stabilizer to your truck can help dampen front steering components in rough terrain or in the event of a road hazard. It's also a proven safety device in the case of a tire blow-out. Shock & boot only. Stabilizer bracket kits sold separately (below).

33610	Steering Stabilizer Shock W/Black Boot	\$45
33611	Steering Stabilizer Shock W/Blue Boot	\$45
33612	Steering Stabilizer Shock W/Red Boot	\$45
33613	Steering Stabilizer Shock W/Yellow Boot	\$45

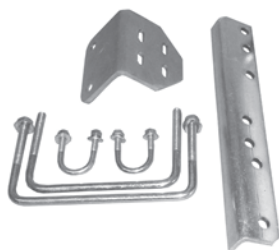
**STEERING STABILIZER BRACKET KIT**

Steering stabilizer bracket kits for use with our steering stabilizer shocks (above).

Note: Part # 33616 & 33618 for use on vehicles with Quad front shock set-up.

**80-96 BRONCO/F-150
W/QUAD SHOCK SET-UP**

33616	Single Stab. Bracket Kit	\$35
33618	Dual Stab. Bracket Kit	\$39

**80-96 BRONCO/F-150
W/O QUAD SHOCK SET-UP**

33615	Single Stab. Bracket Kit	\$35
33617	Dual Stab. Bracket Kit	\$49

DUAL STEERING STABILIZER KIT

Dual steering stabilizer kit includes bracket kit, shocks and boots.

Note: If your vehicle has the front Quad shock set-up, order part #33622 otherwise, go with part #33620.

33620	Dual Steering Stabilizer Kit*	\$138
33622	Dual Steering Stabilizer Kit**	\$130

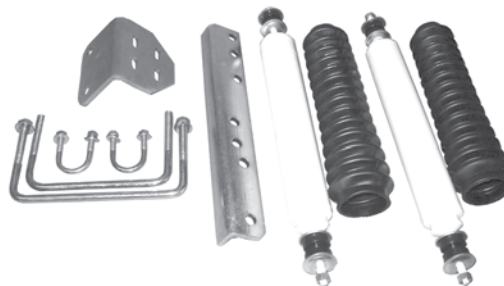

*For use on vehicles with standard front shock set-up.

** For use on vehicles with Quad shock front shock set-up.

BODY SHEET METAL *

AFTERMARKET FENDERS

34004	Fender, RH, 1980-86 Bronco/Pick-up	\$115
34005	Fender, LH, 1980-86 Bronco/Pick-up	\$115
34104	Fender, RH, 1987-91 Bronco/Pick-up	\$100
34105	Fender, LH, 1987-91 Bronco/Pick-up	\$100
34204	Fender, RH, 1992-96 Bronco/Pick-up	\$90
34205	Fender, LH, 1992-96 Bronco/Pick-up	\$90



aftermarket fender 1980-86

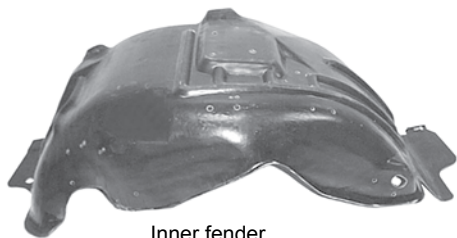

Inner fender

INNER FENDERS

34112	Inner Fender, RH, 1987-97 Bronco/Pick-up	\$40
34113	Inner Fender, LH, 1987-97 Bronco/Pick-up	\$40

AFTERMARKET DOORS

As with all of our body sheet metal, these aftermarket doors come prepped with a black electrostatic coating. Ready for scuffing and painting.

34150A	Door Shell, RH, 1980-86 Bronco/Pick-up	\$150
34150B	Door Shell, LH, 1980-86 Bronco/Pick-up	\$150
34152A	Door Shell, RH, 1987-91 Bronco/Pick-up	\$175
34152B	Door Shell, LH, 1987-91 Bronco/Pick-up	\$175
34154A	Door Shell, RH, 1992-96 Bronco/Pick-up	\$150
34154AM	Door Shell, RH, 1992-96 W/Low Mount Mirror	\$150
34154B	Door Shell, LH, 1992-96 Bronco/Pick-up	\$150
34154BM	Door Shell, LH, 1992-96 W/Low Mount Mirror	\$150



*Shipping note: Almost all of our body panels are too large and/or heavy to be shipped via regular ground carriers (FedEx, UPS, or U.S. mail) and must be truck shipped. Please call for truck shipping price quotes and crate fees.



OEM DOORS

34155A	OEM Door, RH, 1992-96 Bronco/Pick-up	\$825
34155B	OEM Door, LH, 1992-96 Bronco/Pick-up	\$825

AFTERMARKET HOODS

Prepped with a black electrostatic coating.

34001	Hood, 1980-86 Bronco/Pick-up	\$170
34101	Hood, 1987-91 Bronco/Pick-up	\$180
34201	Hood, 1992-96 Bronco/Pick-up	\$150

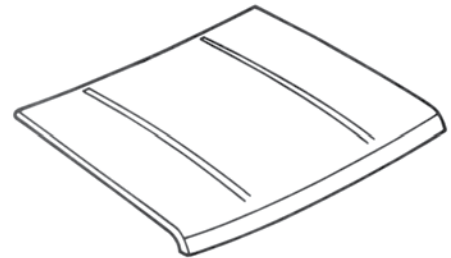

FIBERGLASS HOOD

Direct replacement for stock hood, no more rust, helps ease excess weight of winch and winch bumpers, ridged for extra support, lowered on the front edge to help visibility.

35403	Fiberglass Hood, 80-86 Bronco/Pick-up	\$305
35433	Fiberglass Hood, 87-91 Bronco/Pick-up	\$315
35440	Fiberglass Hood, 92-96 Bronco/Pick-up	\$375
35435	Fiberglass Scooped Hood, 87-91	\$335

QUARTER PANELS

These stamped steel full quarter repair panels are a must for any repair or restoration project. Weld on design. Must be shipped via truck freight. Please call for shipping quotes and crate fees.

34070	Quarter Panel, RH, 1980-86 Bronco	\$205
34071	Quarter Panel, LH, 1980-86 Bronco	\$205
34170	Quarter Panel, RH, 1987-96 Bronco	\$225
34171	Quarter Panel, LH, 1987-96 Bronco	\$225



REAR WHEEL HOUSING

If you are replacing your rear quarter panels chances are you will need to replace these rear wheel housings too. Features stamped steel construction. Fits pick-up or Bronco.

34090	Rear Wheel Housing, RH, 80-86	\$65
34091	Rear Wheel Housing, LH, 80-86	\$65
34192	Rear Wheel Housing, RH, 87-96	\$65
34193	Rear Wheel Housing, LH, 87-96	\$65

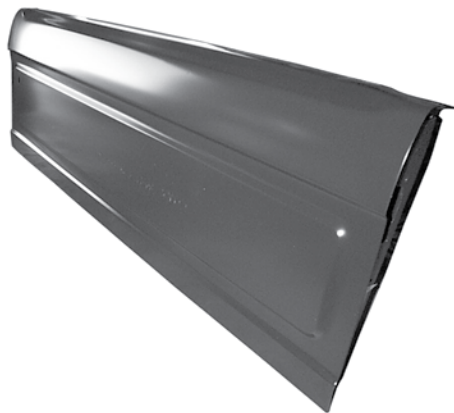
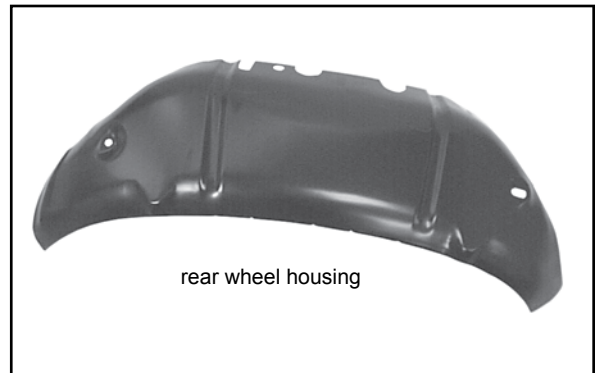

TAILGATE

BRONCO

34500	Tailgate Shell, 1980-82 Bronco	\$300
34501	Tailgate Shell, 1983-96 Bronco	\$275

PICK-UP

34590	Tailgate Shell, 1980-86 Pick-up	\$105
34592	Tailgate Shell, 1987-97 Pick-up	\$105
34594	Tailgate, Loaded, 87-97 Pick-up	\$209

REAR PATCH PANELS



QUARTER REPAIR PANEL

34082	Patch Panel, RH, 1980-86 (16"x39")	\$35
34083	Patch Panel, LH, 1980-86 (16"x39")	\$35
34181	Patch Panel, LH, 1987-96 (13"x39")	\$35
34182	Patch Panel, RH, 1987-96 (13"x39")	\$35

**1980-86 BRONCO**

34088	Bronco, Lower ¼ Corner, RH	\$34
34089	Bronco, Lower ¼ Corner, LH	\$34

1987-96 BRONCO

34183	Front Lower ¼, LH	\$45
34184	Front Lower ¼, RH	\$45
34185	Rear Lower ¼, LH	\$45
34186	Rear Lower ¼, RH	\$45

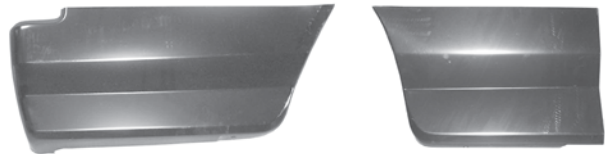
**1980-86 TRUCK**

34084	Front Lower Bedside, LH	\$42
34085	Front Lower Bedside, RH	\$42
34086	Rear Lower Bedside, RH	\$42
34087	Rear Lower Bedside, LH	\$42

1987-96 TRUCK

34174	Front Lower Bedside, LH	\$40
34175	Front Lower Bedside, RH	\$40
34176	Rear Lower Bedside, RH	\$42
34177	Rear Lower Bedside, LH	\$42



CORE SUPPORT

34002	Core Support, 1980-86 Bronco/Pick-up	\$170
34102	Core Support, 1987-91 Bronco/Pick-up	\$180
34202	Core Support, 1992-96 Bronco/Pick-up	\$189
34202A	Core Support, Diesel 92-97	\$269
34203	Header Panel, OEM 92-96	\$205
34203A	Header Panel, Aftermarket 92-96	\$119



FRONT APRON PANEL

34000	Front Apron, 1980-86 Bronco/Pick-up	\$30
34100	Front Apron, 1987-91 Bronco/Pick-up	\$50
34200	Front Apron, 1992-96 Bronco/Pick-up	\$50
34095	Rear Cross Sill (above valance)	\$190



FLOOR PANS

34040	Floor Pan, RH, 80-96 Bronco/ Pick-up	\$35
34041	Floor Pan, LH, 80-96 Bronco/ Pick-up	\$35

FLOOR REPAIR

34037	Cab Floor, Outer, RH, 80-96 Bronco/Pick-up	\$49
34038	Cab Floor, Outer, LH, 80-96 Bronco/ Pick-up	\$49

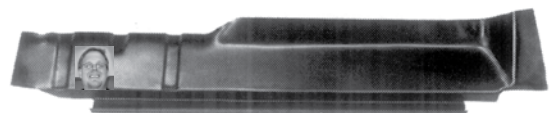



rocker panel, oem style



rocker w/door post*

ROCKER PANELS

34030	Rocker Panel, RH, 1980-86 Bronco	\$38
34031	Rocker Panel, LH, 1980-86 Bronco	\$38
34130	Rocker Panel, RH, 1987-96 Bronco	\$55
34131	Rocker Panel, LH, 1987-96 Bronco	\$55
34032	Rocker Panel, RH, Extended Cab	\$65
34033	Rocker Panel, LH, Extended Cab	\$65
34034	RH Rocker W/Door Post*	\$38
34035	LH Rocker W/Door Post*	\$38

* Fits over OEM rocker panel

CAB CORNERS

Bring your cab corners back from the dead with these stamped steel repair panels. Sold individually. Specify RH or LH.

34021	Cab Corner, 1980-86, RH	\$25
34022	Cab Corner, 1980-86, LH	\$25
34121	Cab Corner, 1987-96, RH	\$25
34122	Cab Corner, 1987-96, LH	\$25
34023	Cab Corner, 80-86, RH, Super Cab	\$40
34023L	Cab Corner, 80-86, LH, Super Cab	\$40
34123	Cab Corner, 87-96, RH Super Cab	\$40
34124	Cab Corner, 87-96, LH, Super Cab	\$40

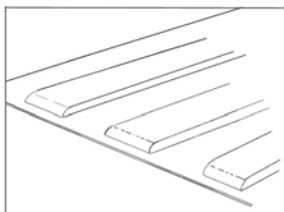
**REAR BED FLOOR**

34094	Rear Bed Floor Patch Panel (48" X 16")	\$35
-------	--	------

DOOR POST REPAIR

34024	Lower Front Door Post, 80-96 Bronco/Pick-up, RH	\$25
34025	Lower Front Door Post, 80-96 Bronco/Pick-up, LH	\$25
34060	Lower Rear Door Post, 80-96 Bronco/Pick-up, RH	\$18
34061	Lower Rear Door Post, 80-96 Bronco/Pick-up, LH	\$18

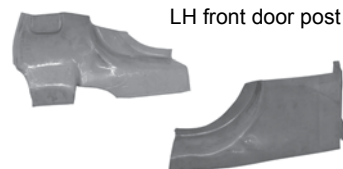

LH front door post

RH rear door post

DOOR PARTS

DOOR GLASS WEATHER-STRIP

Replace the old worn out weather-strip on your truck with these high quality replacement parts from JBG. Complete kit includes inner & outer door glass weather-strip and door frame glass run weather-strip (6 pc.kit does both doors). Door glass weather-strip kit includes inner & outer weather-strip only (4pc.set).

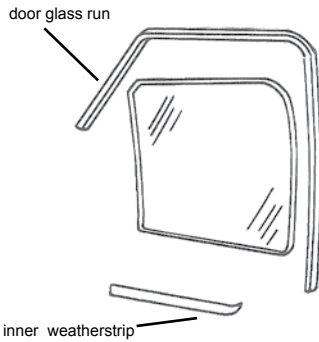

34395	Complete Glass Weather-strip Kit (6pc.) 1980-86	\$75
34396	Complete Glass Weather-strip Kit (6pc.) 1987-96	\$69
34386A	Door Glass Weather-strip Kit (4pc. kit) 1980-86	\$45
34388A	Door Glass Weather-strip Kit (4pc. kit) 1987-96	\$42
34394	Door Weather-strip Run 80-96	\$12

VENT WINDOW RUBBER

36007A	Vent Window Rubber, AFT, 80-86 (pair)	\$37
36009A	Vent Window Rubber, AFT, 87-91 (pair)	\$39
36009	Vent Window Rubber, 87-91, RH (OEM)	\$92
36010	Vent Window Rubber, 87-91, LH (OEM)	\$92
36011	Vent Window Rubber, 92-96, RH (OEM)	\$210
36012	Vent Window Rubber, 92-96, LH (OEM)	\$210
36013	Vent Window Rubber, 92-97 Pair (aft)	\$39

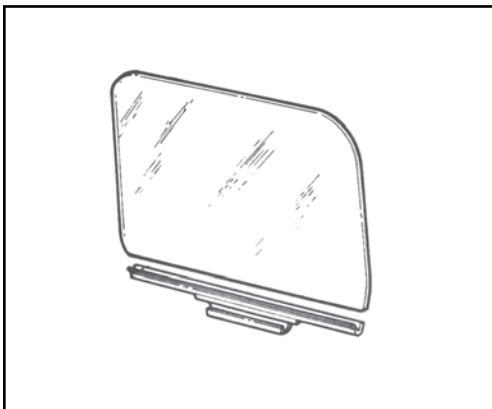

DOOR GLASS

34330	Door Glass, 80-86 RH, Clear (new)	\$50
34330T	Door Glass, 80-86 RH, Tinted (new)	\$50
34331	Door Glass, 80-86 LH, Clear (new)	\$50
34331T	Door Glass, 80-86 LH, Tinted (new)	\$50
34333L	Door Glass, 87-93 LH, Tinted (new)	\$49
34333R	Door Glass, 87-93 RH, Tinted (new)	\$49
34332	Door Glass Channel, 80-91	\$30
34334	Door Glass Setting Channel Tape	\$4

VENT WINDOW GLASS

34300LC	Vent Window Glass, LH Clear, 80-91 (new)	\$22
34300LT	Vent Window Glass, LH Tinted, 80-91 (new)	\$22
34300RC	Vent Window Glass, RH Clear, 80-91 (new)	\$22
34300RT	Vent Window Glass, RH Tinted, 80-91 (new)	\$22
34301L	Vent Window Frame LH 92-97	\$200
34301R	Vent Window Frame RH 92-97	\$200
34303R	Vent Frame & Glass 92-96 RH	\$80
34303RGO	Vent Glass Only 92-96 RH	\$20
34303L	Vent Frame & Glass 92-96 LH	\$80
34303LGO	Vent Glass Only 92-96 LH	\$20
34302L	Vent Window Assembly 92-96 LH	\$290
34302R	Vent Window Assembly 92-96 RH	\$290
34304L	Vent Window Handle 80-91 LH	\$11
34304R	Vent Window Handle 80-91 RH	\$11

**WINDOW REGULATOR**

34335	Manual Regulator, RH, 80-91	\$35
34336	Manual Regulator, RH, 92-96	\$35
34337	Manual Regulator, LH, 80-91	\$49
34338	Manual Regulator, LH, 92-96	\$35
34339	Power Regulator, RH, 80-96	\$35
34340	Power Regulator, RH, 80-96	\$35
34344	Window Regulator Roller	\$6
34345	Window Crank Handle, 80-86	\$6
34346	Window Crank Handle, 87-96	\$5

**POWER WINDOW MOTOR**

34347	80-04/92, LH, Door Glass Motor	\$50
34347A	05/92-96, LH, Door Glass Motor	\$50
34348	80-04/92, RH, Door Glass Motor	\$50
34348A	05/92-96, RH, Door Glass Motor	\$50
34349	80-04/92, Window Motor Gear	\$18
34349A	05/92-96, Window Motor Gear	\$12

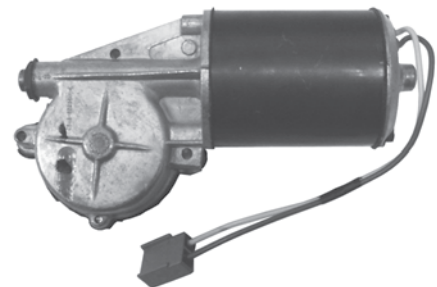

DOOR LATCH

34350	Door Latch, RH, 80-91	\$55
34352	Door Latch, LH, 80-91	\$35
34353	Door Latch, LH, 92-96	\$135
34351	Door Latch, RH, 92-96	\$135
34354	Latch Rod Clip	\$1

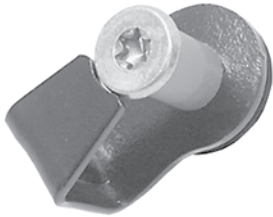

DOOR STRIKER

34385	Door Striker, 80-86, Each	\$10
34385A	Door Striker, 87-96, Each	\$10

DOOR LATCH CABLE

34380	Door Latch Cable, 92-97	\$16
-------	-------------------------	------



INTERIOR DOOR HANDLE

34368	Interior Handle, 80-86, RH, Chrome	\$8
34369	Interior Handle, 87-96, RH, Black	\$6
34370	Interior Handle, 80-86, LH, Chrome	\$8
34371	Interior Handle, 87-96, LH, Black	\$6

EXTERIOR DOOR HANDLE

34372	Outside Handle, RH, 80-96	\$29
34373	Outside Handle, LH, 80-96	\$29
34366LH	Door Handle Pads, LH	\$8
34366RH	Door Handle Pads, RH	\$8
34372B	Outside Handle, RH 80-97, Black	\$30
37373B	Outside Handle, LH 80-97, Black	\$30



POWER LOCK ACTUATOR

34399	Power Lock Actuator, 80-93	\$55
34399A	Power Lock Actuator, 94-96	\$45



power lock actuator

**DOOR MIRROR 1980-86 (WITH MOUNTING HARDWARE)**

34463	Mirror, Stainless, 80-86, RH	\$29
34464	Mirror, Stainless, 80-86, LH	\$29

POWER DOOR MIRROR 1992-96 (WITH HARDWARE)

34474	Power Mirror, Black, 92-96, RH	\$69
34475	Power Mirror, Black, 92-96, LH	\$69
34476	Power Mirror, Chrome/Black, 92-96, RH	\$69
34477	Power Mirror, Chrome/Black, 92-96, LH	\$69

MANUAL DOOR MIRRORS 1992-96 (WITH HARDWARE)

34470	Mirror, Black, 92-96, RH	\$36
34471	Mirror, Black, 92-96, LH	\$36
34472	Mirror, Chrome, 92-96, RH	\$40
34473	Mirror, Chrome, 92-96, LH	\$40

**VENT WINDOW LOCKS**

Help make your truck more secure with these heavy duty steel vent window locks. Installs easily and stores in the glove box when not in use.

34310	Vent Window Locks, Pair	\$11
-------	-------------------------	------



DOOR LOCK CYLINDERS

34374	Door Lock Set, 80-86	\$25
34374A	Door Lock Set, 87-91	\$29
34375	Door Lock Set, 92-96	\$38

DOOR HINGES (OEM)

34376	Upper Hinge, RH, 80-96	\$120
34377	Upper Hinge, LH, 80-96	\$120
34378	Lower Hinge, RH or LH, 80-96	\$120
34383	Upper Hinge Spring Repair	\$6.95
34384	Door Hinge Repair Kit (1 hinge)	\$6
34398	Door Hinge Roller, 80-96	\$5

DOOR HINGES (AFTERMARKET)

34376A	Upper Hinge, RH, 80-96	\$50
34377A	Upper Hinge, LH, 80-96	\$50
34378A	Lower Hinge, RH or LH, 80-96	\$40



window switch



lock switch

POWER ACCESSORY SWITCHES

34409	Power Lock Switch, 81-86 Bronco/Pick-Up	\$20
34410	Power Window Switch, 81-86, LH	\$34
34411	Power Window Switch, 81-86, RH	\$16
34412	Power Window Switch, 87-91, LH or RH	\$13
34416	Power Lock Button, 92-96, RH	\$32
34417	Power Lock Button, 92-96, LH	\$32
34418	Power Window Switch, 92-96, RH or LH	\$12
34419	Power Mirror Switch, 92-96	\$68
34415	4 Way Power Window Switch, 89-97	\$35

DOOR PANELS



1980-86 W/MANUAL LOCKS & WINDOWS

Replacement door panels are designed to closely resemble the original factory panel. Attaching hardware and armrests included. OEM chrome trim not included but may be transferred from original panel.

34420LBL	Door Panels (lt blue)	\$159	34420	Door Panels (gray)	\$159
34420LBR	Door Trim Panels (lt brown)	\$159	34420BK	Door Panels (black)	\$159
34420MR	Door Trim Panels (maroon)	\$159	34420DBL	Door Panels (dk blue)	\$159
34420RD	Door Trim Panels (red)	\$159	34420DBR	Door Panels (dk brown)	\$159
			34420GRN	Door Panels (dk green)	\$159

1980-86 NO POWER

Made from Ford factory tooling. These are designed to match the original factory door panel and includes weather stripping. Fasteners are included with panels. OEM chrome trim not provided but may be transferred from original panel. Can be painted to match interior color scheme. Also recommend part #34460 Pre-Cut Insulation Pads (Pair). 34480 Door Armrests

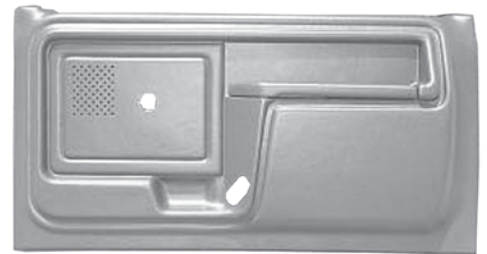

34419B 1980-86 Door Panels, No Power, Black \$150



1980-86 ARMREST

Armrest are designed to closely resemble the factory original armrest. Sold in pairs. Attaching hardware included.

34429BK 1980-86 Arm Rest, Pair, Black \$49

1980-86 SLIDE LOCK DOOR PANELS



34428	Door Panels (gray)	\$159
34428BK	Door Trim Panels (black)	\$159
34228DBL	Door Trim Panels (dark blue)	\$159
34428DBR	Door Panels (dk brown)	\$159
34428GRN	Door Panels (dk green)	\$159
34428LBL	Door Panels (lt blue)	\$159
34428LBR	Door Panels (lt brown)	\$159
34428MR	Door Panels (maroon)	\$159
34228RD	Door Trim Panels (red)	\$159

1980-86 W/POWER LOCKS & WINDOWS

34422	Door Panels (gray)	\$159
34422BK	Door Panels (black)	\$159
34422DBL	Door Panels (dk blue)	\$159
34422DBR	Door Panels (dk brown)	\$159
34422GRN	Door Panels (dk green)	\$159
34422LBL	Door Panels (lt blue)	\$159
34422LBR	Door Panels (lt brown)	\$159
34422MR	Door Panels (maroon)	\$159
34422RD	Door Panels (red)	\$159



1980-86 W/POWER WINDOWS ONLY

34424	Door Panels (gray)	\$159
34424BK	Door Panels (black)	\$159
34424DBL	Door Panels (dark blue)	\$159
34424DBR	Door Panels (dark brown)	\$159
34424GRN	Door Panels (dark green)	\$159
34424LBL	Door Panels (lt blue)	\$159
34424LBR	Door Panels (lt brown)	\$159
34424MR	Door Panels (maroon)	\$159
34424RD	Door Panels (red)	\$159

1980-86 W/POWER LOCKS ONLY

34426	Door Panels (gray)	\$159
34426BK	Door Panels (black)	\$159
34426DBL	Door Panels (dk blue)	\$159
34426DBR	Door Panels (dk brown)	\$159
34426GRN	Door Panels (dk green)	\$159
34426LBL	Door Panels (lt blue)	\$159
34426LBR	Door Panels (lt brown)	\$159
34426MR	Door Panels (maroon)	\$159
34426RD	Door Panels (red)	\$159



1987-91 W/MANUAL LOCKS & WINDOWS

These door panels are designed to closely resemble the original factory door panel and includes weather stripping and a cloth insert. Panels attach with included plastic fasteners inserted from the outside through pre-drilled holes. Includes padded arm rests. Sold in pairs only.

34432	Door Panels (gray)	\$199	34432GRN	Door Panels (green)	\$199
34432BK	Door Panels (black)	\$199	34432LBL	Door Panels (lt blue)	\$199
34432DBL	Door Panels (dk blue)	\$199	34432LBR	Door Panels (lt brown)	\$199
34432DBR	Door Panels (dk brown)	\$199	34432MR	Door Panels (maroon)	\$199
			34432RD	Door Panels (red)	\$199

1987-91 W/POWER WINDOWS & LOCKS

These door panels incorporate all of the same great features as the panels listed above, but are designed for use on vehicles equipped with power windows and door locks.



34449	Door Panels (gray)	\$199	34454	Door Panels (lt blue)	\$199
34450	Door Panels (dk blue)	\$199	34455	Door Panels (lt brown)	\$199
34451	Door Panels (dk brown)	\$199	34456	Door Panels (maroon)	\$199
34452	Door Panels (black)	\$199	34457	Door Panels (red)	\$199
34453	Door Panels (dk green)	\$199			



ARMREST

OEM Armrest. Sold individually, not sold in pairs.

- | | | |
|-------|--------------------------------|------|
| 34446 | Armrest, 87-91, Smoke Gray, LH | \$36 |
| 34447 | Armrest, 87-91, Smoke Gray, RH | \$36 |

DOOR PANEL INSULATION

Pre-cut insulation pads for use behind the door panels help diminish road noise and drafts.

- | | | |
|--------|--------------------------------------|------|
| 34460 | Pre-Cut Insulation Pads, Pair, 80-86 | \$25 |
| 34460A | Pre-Cut Insulation Pads, Pair, 87-91 | \$25 |
| 34460B | Pre-Cut Insulation Pads, Pair, 92-96 | \$25 |

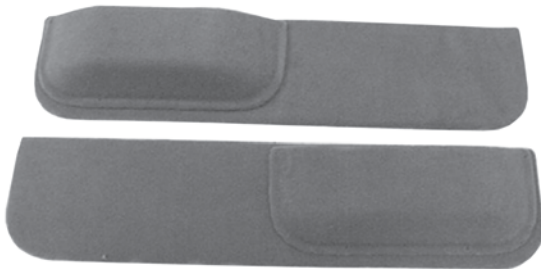
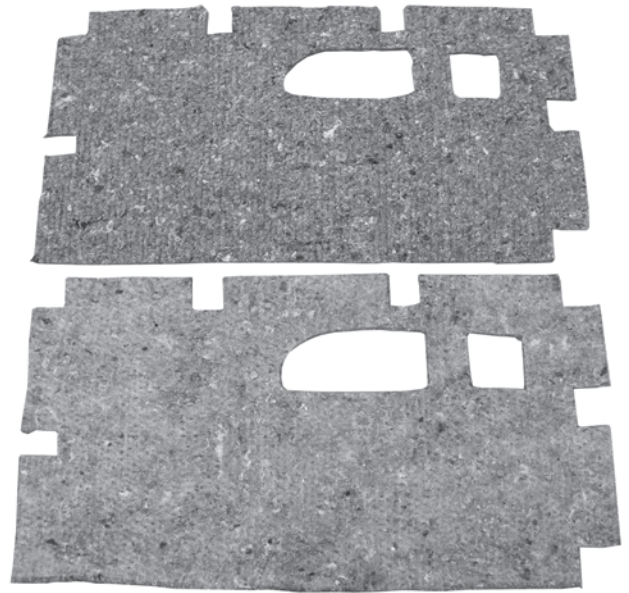

LOWER KICK PANELS (WITH MAP POCKETS)

These aftermarket lower door panels closely resemble the factory panels. Features a fully carpeted panel with map pockets built in. Sold in pairs. Attaching hardware included.

- | | | |
|----------|-------------------------|------|
| 34440 | Lower Panels (black) | \$47 |
| 34440DBL | Lower Panels (dk blue) | \$47 |
| 34440DBR | Lower Panels (dk brown) | \$47 |
| 34440GR | Lower Panels (gray) | \$47 |
| 34440GRN | Lower Panels (green) | \$47 |
| 34440LBL | Lower Panels (lt blue) | \$47 |
| 34440LBR | Lower Panels (lt brown) | \$47 |
| 34440MR | Lower Panels (maroon) | \$47 |
| 34440RD | Lower Panels (red) | \$47 |

BRONCO TAILGATE PARTS

BRONCO TAILGATE SHELL

Choose from an original OEM tailgate shell or high quality aftermarket duplicate. Both are shipped ready to accept your internal parts.

34500	Tailgate Shell, Aftermarket, 80-82 Bronco	\$300
34501	Tailgate Shell, Aftermarket, 83-96 Bronco	\$275
34507	Diamond Plate Access Cover	\$85

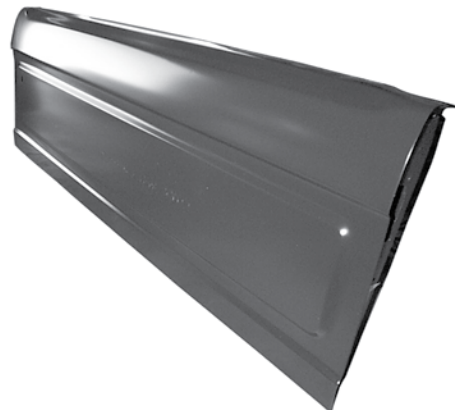

tailgate latch

tailgate striker



check cable

TAILGATE LATCH AND CHECK CABLE

34510	Tailgate Latch, RH, 83-96 Bronco	\$84
34512	Tailgate Latch, LH, 83-96 Bronco	\$84
34562	Check Cable, 80-96 Bronco	\$12
34515	Tailgate Striker, 83-96	\$15
34514	Tailgate Striker Bushings, 83-96	\$6

REAR WINDOW ACTUATING SWITCH

34576	80-86 Rear Window Dash Switch	\$38
34577	87-91 Rear Window Dash Switch	\$56
34578	92-96 Rear Window Dash Switch	\$54

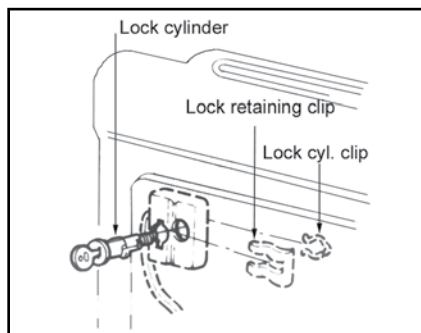

LOCK AND RELATED

34525	Tailgate Lock Cylinder 80-96 Bronco	\$84
34526	Lock Cylinder Clip 80-96 Bronco	\$9
34528	Lock Retaining Clip	\$3

TAILGATE HANDLE & LATCH

34516	Latch Rod, RH or LH, 80-82 Bronco	\$12
34517	Latch Rod, RH or LH, 83-96 Bronco	\$12
34517A	Latch Control Rod	\$9
34521	Tailgate Handle	\$39
34534	Latch Rod Clip, 80-96 Bronco	\$1
34518	Latchrod Isolator Clip	\$.60
34523	Grommet, Tailgate Handle Rod	\$3

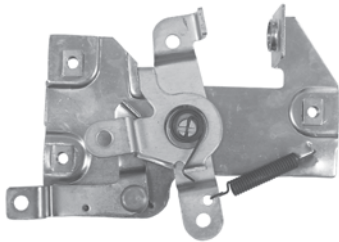
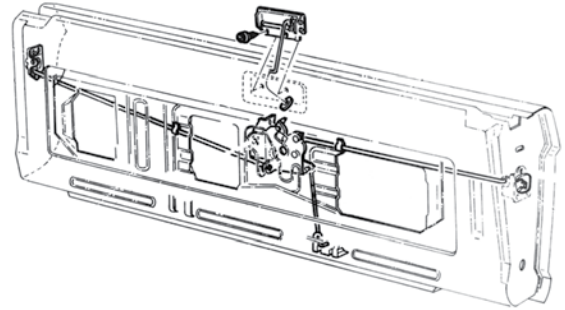

LATCH RELEASE MECHANISM

34520	Release Mechanism, 80-96 Bronco, Aft	\$35
-------	--------------------------------------	------

WINDOW REGULATOR PARTS

34555	Regulator Bracket	\$49
34556	Regulator Bracket Bushing	\$6
34557	Regulator Roller	\$6
34560	Bottom Glass Bumper	\$5

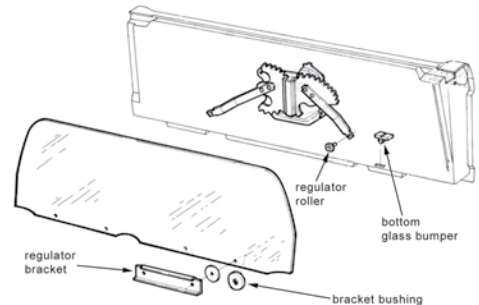

WINDOW MOTOR

Rear window quit working? You may need a new lift motor. Motor spins but the glass doesn't move? Try one of our replacement gears.

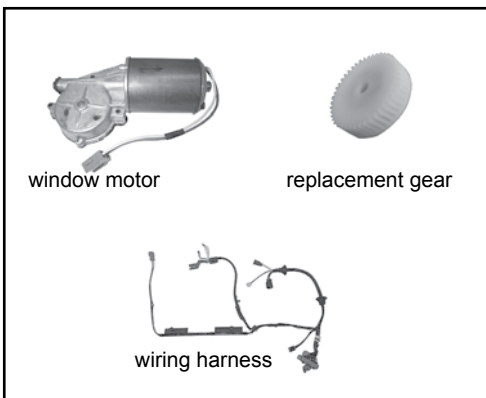

34522A	Window Lift Motor, 80-95	\$50
34553A	Window Lift Motor, 1996	\$50
34554	Replacement Gear For Motor, 80-95	\$18
34554A	Replacement Gear For Motor, 1996	\$12
34580	Tailgate Wiring Harness, 80-82 Bronco	\$250
34582	Tailgate Wiring Harness, 83-86 Bronco	\$250
34584	Tailgate Wiring Harness, 87-93 Bronco	\$soon
34586	Tailgate Wiring Harness 94-96 Bronco	\$soon

WINDOW TRACK AND WEATHERSTRIP

34558	Window Track, OEM, 80-96 Bronco	\$75
34558A	Window Track, Aftermarket, 80-96 Bronco	\$39
34599	Window Track, Replacement Rubber (pair)	\$14
34543	Inner & Outer Weatherstrip Belt Kit	\$55
34544	Weatherstrip End, OEM (RH)	\$61
34544A	Weatherstrip End, AFT (RH)	\$16
34545	Weatherstrip End OEM (LH)	\$61
34545A	Weatherstrip End, Aft (LH)	\$16

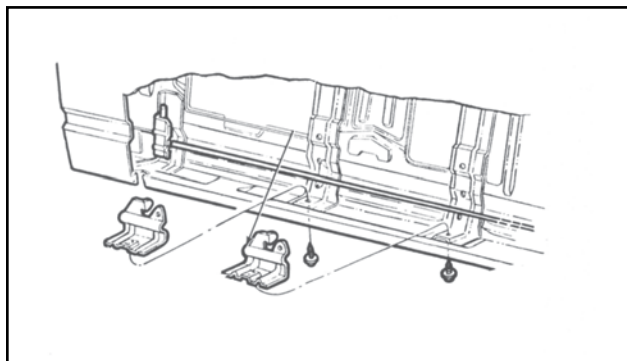
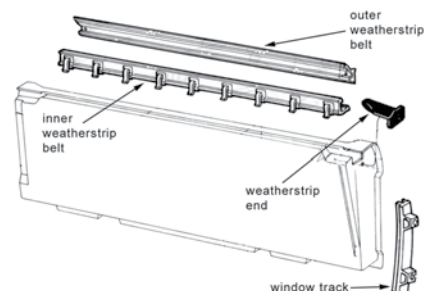
**TORSION BAR AND RELATED**

The 80-96 Bronco tailgates are equipped with a torsion bar to aid in lifting the tailgate when closing it. This bar is attached to the tailgate with brackets that are prone to rust and deterioration. Replace yours with these new aftermarket pieces.

34570	Torsion Bar	\$79
34574	Internal Torsion Bar Bracket	\$18

TAILGATE HINGE REPAIR

New and exclusively from the Bronco Graveyard. Tailgate hinge pin repair kit includes: Stainless Steel hinge pins, bolts and new Bronze bushings to repair 2 hinges. Restore your old worn out set of hinges to better than new condition. Requires drilling a 17/32" hole.

34567	Tailgate Hinge Repair Kit, 80-96	\$15
-------	----------------------------------	------

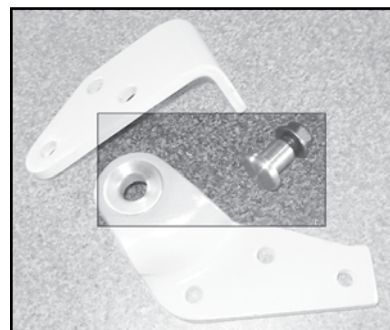

Kit includes bushing & pin only.

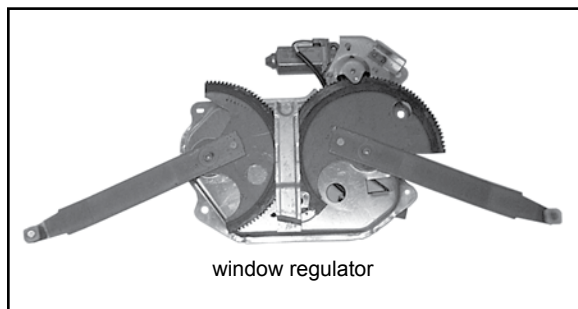
**WINDOW REGULATOR**

Rear tailgate window regulator includes new electric lift motor and window roller bushings.

34551	Window Regulator, No motor, 80-96	\$90
-------	-----------------------------------	------

TRUCK TAILGATE PARTS

TAILGATE

High quality replacement or OEM tailgates. Tailgate shell is bare tailgate, ready to accept your internal parts. Loaded tailgate is ready to bolt on with latches, rods, handle and access cover.

TAILGATE SHELL

34590	Truck Tailgate, 80-86 (aft)	\$105
34591	Truck Tailgate, 80-86 (oem)	\$350
34592	Truck Tailgate, 87-97 (aft)	\$105
34593	Truck Tailgate, 87-91 (oem)	\$399
34595	Truck Tailgate, 92-97 (oem)	\$399

LOADED TAILGATE

34594	Truck Tailgate, 87-97, Loaded	\$209
-------	-------------------------------	-------



80-86 truck tailgate



87-91 truck tailgate



TAILGATE HANDLE

Chrome tailgate handle is a direct replacement for the original handle.

34596	Tailgate Handle, 1980-86 PU	\$25
34597	Tailgate Handle, 1987-96 PU	\$15

MISCELLANEOUS HARDWARE

34563	Tailgate Check Cable, 80-96 Truck	\$15
34598	Tailgate Striker, 89-96 Truck	\$15
345971	Tailgate Latch Rods, 87-97, Pair	\$18
34599	Tailgate Bushing Kit, 87-96	\$12
34599A	Upper Tailgate Bumpers, 80-97	\$9
34599L	Tailgate Hinge, LH, 87-97	\$11
34599R	Tailgate Hinge, RH, 87-97	\$11

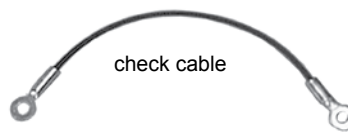

check cable



tailgate latch striker

GRILL

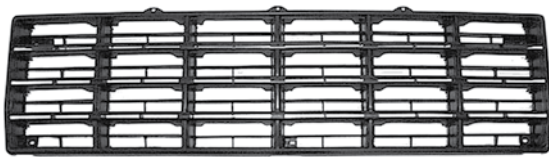

1980-86 GRILL

34700	Grill, 80-81 (argent)	\$50
34704	Grill, 80-81 (chrome)	\$65
34706	Grill, 82-86 (argent)	\$50
34708	Grill, 82-86 (black)	\$50
34710	Grill, 82-86 (chrome)	\$65

1987-96 GRILL

34740	Grill, 87-88 (black)	\$50
34742	Grill, 87-88 (chrome/argent)	\$50
34744	Grill, 89-91 (chrome/argent)	\$50
34746	Grill, 89-91 (black/argent)	\$65
34755	Grill, 92-96 (argent)	\$60
34756	Grill, 92-96 (black)	\$55
34757	Grill, 92-96 (chrome)	\$70

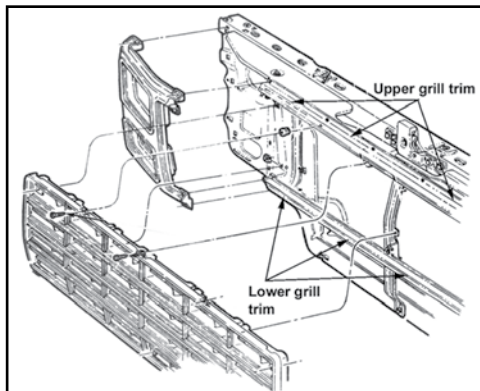

GRILL TRIM

34724	Upper Grill Molding, 1980-86	\$19
34726	Lower Grill Molding, 1980-86	\$19

HEADLIGHT DOORS & BUCKETS

34816	HL Door RH, 80-86 (chrome/argent)	\$25
34817	HL Door LH, 80-86 (chrome/argent)	\$25
34818	HL Door RH, 80-86 (chrome/black)	\$25
34819	HL Door LH, 80-86 (chrome/black)	\$25
34840	HL Door RH, 92-96 (chrome)	\$20
34841	HL Door LH, 92-96 (chrome)	\$20
34842	HL Door RH, 92-96 (black)	\$15
34843	HL Door LH, 92-96 (black)	\$15
34844	HL Door RH, 92-96 (argent)	\$15
34845	HL Door LH, 92-96 (argent)	\$15

**GRILL EMBLEMS**

35172	"FORD" Oval Grill Emblem, 83-86	\$33
35174	"FORD" Oval Grill Emblem, 87-88	\$34
35175	"FORD" Oval Grill Emblem, 92-96	\$25

HEADLIGHT HARDWARE

34800	Headlight Retainer	\$13
34808	HL Bucket, 80-86, RH, Argent	\$35
34809	HL Bucket, 80-8,6 LH, Argent	\$35
34813	Headlight Adjuster	\$3
34815	Headlight Bucket Spring	\$4



LIGHTING



TAIL LIGHTS

34900	Tail Light Lens, RH, 1980-86 Bronco/Pick-up	\$20
34902	Tail Light Lens, LH, 1980-86 Bronco/Pick-up	\$20
34904	Tail Light Lens, RH, 1987-88 Bronco/Pick-up	\$23
34905	Tail Light Lens, LH, 1987-88 Bronco/Pick-up	\$23
34907	Tail Light Lens, RH, 1989-96 Bronco/Pick-up	\$22
34908	Tail Light Lens, LH, 1989-96 Bronco/Pick-up	\$22

PARK LIGHT & SIDE MARKER

34910	Park Light Lens, Clear, 1980-86	\$10
34911	Park Light Lens, Amber, 1980-86	\$10
34912	Park Light Lens, RH, Plain, 1987-91	\$45
34914	Park Light Lens, LH, Plain, 1987-91	\$45
34916	Park Light Chrome, RH, 1987-91	\$48
34918	Park Light Chrome, LH, 1987-91	\$48
34920	Park Light Lens, RH, 1992-96	\$22
34922	Park Light Lens, LH, 1992-96	\$22
34930	Side Marker Lens Amber, RH, 1980-86	\$10
34932	Side Marker Lens Amber, LH, 1980-86	\$10
34936	Side Marker Lens Clear, RH, 1992-96	\$12
34938	Side Marker Lens Clear, LH, 1992-96	\$12

1989-91 LH park light



1992-96 RH park light



1980-86 side marker light



ALFAS MAXIMUM INTENSITY LIGHTING

Alfas Maximum Intensity replacement bulbs are the best approximation to a full HID Xenon lighting system. Alfas can be installed on any vehicle without modifications, complications, or the excessive costs of an HID system.

34806	Alfas 9004 Bulbs, 87-91, Pair	\$35
34807	Alfas 9007 Bulbs, 92-96, Pair	\$35

HEADLIGHT ASSEMBLIES

34805	H4 Headlight Conversion, 80-86	\$79
34830	Plain RH, 1987-91	\$125
34831	Plain LH, 1987-91	\$125
34836	Chrome RH, 1987-91	\$147
34837	Chrome LH, 1987-91	\$147
34940	Headlamp Lens, RH, 1992-96	\$40
34941	Headlamp Lens, LH, 1992-96	\$40

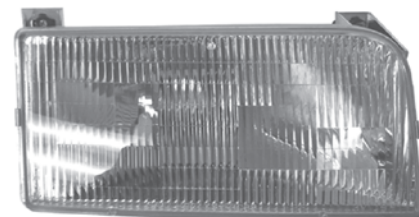

1992-96 RH headlight assembly

BUMPERS



DIAMONSTEP BUMPER

Traditional utility bumper with embossed steel step plate, famous for function and reliability. Available in semi-gloss black, silver or chrome.

35060	Rear Diamondstep Bumper (black)	\$169
35061	Rear Diamondstep Bumper (silver)	\$169
35062	Rear Diamondstep Bumper (chrome)	\$269

SURESTEP BUMPER

Classic step bumper with molded polymer step pad for sure footing.

35063	Rear Surestep Bumper (silver)	\$205
35064	Rear Surestep Bumper (chrome)	\$259



SURESTEP DELUXE XLT

Fey's Surestep Deluxe XLT™ bumper is designed to closely resemble Ford's product while providing increased towing capacity. Features wrapped step pad for added protection and great looks.

35066	Rear Surestep Deluxe XLT (silver)	\$185
35067	Rear Surestep Deluxe XLT (chrome)	\$259



REAR STEP BUMPER BRACKETS

Bumper brackets designed for use with Fey rear step bumpers.

35058	Fey Bracket Kit 1980-96 Pick-up	\$38
35059	Fey Bracket Kit 1980-96 Bronco	\$38

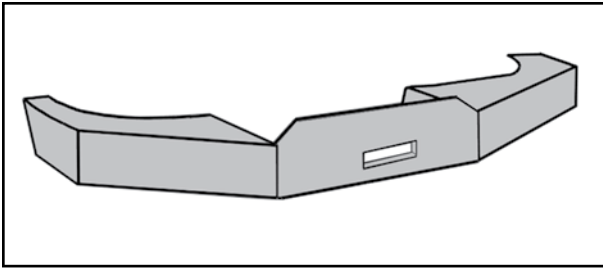
**STAGE I PLATE STEEL WINCH BUMPER**

35017	Winch Bumper 80-86	\$700
35017A	Winch Bumper 87-91	\$700
35017B	Winch Bumper 92-96	\$700

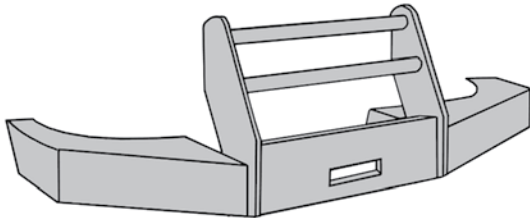
**STAGE II WINCH BUMPER**

35018	W/Push Bar 80-86	\$800
35018A	W/Push Bar 87-91	\$800
35018B	W/Push Bar 92-96	\$800

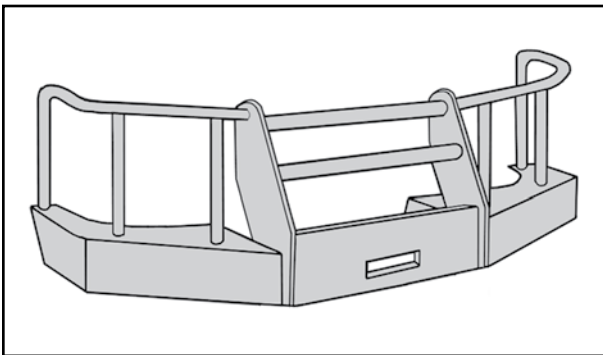
**STAGE III WINCH BUMPER**

35019	W/Push Bar & Guards 80-86	\$900
35019A	W/Push Bar & Guards 87-91	\$900
35019B	W/Push Bar & Guards 92-96	\$900

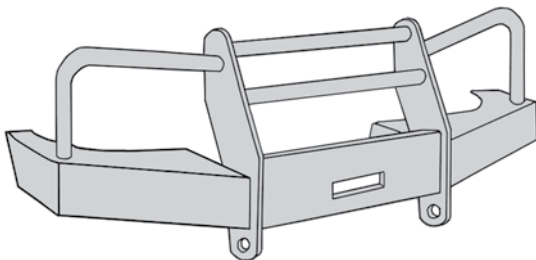
**STAGE V WINCH BUMPER**

35020	W/Push Bar & Light Guards 80-86	\$850
35020A	W/Push Bar & Light Guards 87-91	\$850
35020B	W/Push Bar & Light Guards 92-96	\$850

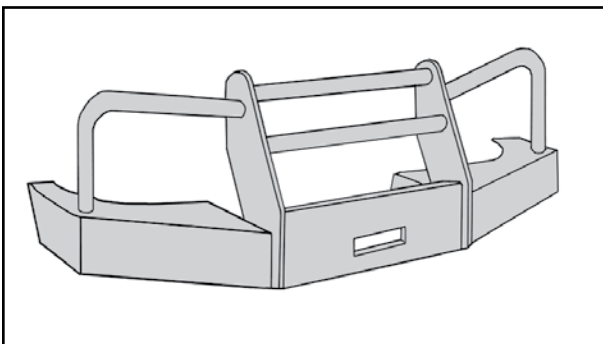
**STAGE VI WINCH BUMPER**

35021	W/Push Bar & Mesh Guards 80-86	\$1000
35021A	W/Push Bar & Mesh Guards 87-91	\$1000
35021B	W/ Push Bar & Mesh Guards 92-96	\$1000

Note: All plate steel bumpers are truck shipped. FOB Monroe, LA.



1980-86 FRONT BUMPER

35000	Chrome Front Bumper	\$120
35005	Painted Front Bumper	\$110

1987-91 FRONT BUMPER

35002	Chrome Front Bumper	\$209
35003	Chrome Front Bumper, W/Trim Holes	\$199
35006	Painted Front Bumper	\$149
35004	OEM Plastic Front Bumper Strip	\$58



1992-96 FRONT BUMPER

35007	Chrome Front Bumper, Plain	\$189
35008	Chrome Front Bumper, W/Trim Holes	\$189
35009	Painted Front Bumper, Plain	\$135
35015	OEM Plastic Trim (without vent holes)	\$58



ATTACHING HARDWARE

35014	Bumper Bolt	\$2
35013L	Front Bumper Bracket, 87-91, LH	\$20
35013R	Front Bumper Bracket, 87-91, RH	\$20
35015L	Front Bumper Bracket, 92-96, LH	\$20
35015R	Front Bumper Bracket, 92-96, RH	\$20





ROCK SOLID FRONT WINCH BUMPER

These bumpers are truly designed with the full size owner in mind. The bumper's .250 metal is strong enough to handle a 15,000 lb. capacity winch and has Hi-Lift jack mounting holes.

35030	92-96 Rock Solid Front Bumper	\$814
35032	87-91 Rock Solid Front Bumper	\$814
35034	80-86 Rock Solid Front Bumper	\$814



ROCK SOLID REAR BUMPER

Designed to match the Rock Solid front bumper, this rear bumper incorporates similar design and construction as the front bumper (above). Bumper in pictures is shown with optional tire rack & gas can mount.

35036	80-96 Rear, W/Tire Rack	\$665
35038	80-96 Rear, W/Rack & Can Mt.	\$1025
35040	80-96 Rear, No Rack or Can	\$445



MILEMARKER WINCHES

HYDRAULIC WINCH

Used in all types of vehicles every day in all types of conditions, from -50° to 135° the power steering pump must perform for years without service or adjustment. It has to withstand every type of abuse without failure. Mile marker chose to design a winch around this reliable power source. After rigorous testing they found the pump would operate continuously while pulling heavy loads and actually ran cooler when winching than off-road driving.

19001	HI9000lb Hydraulic Winch	\$1199
19003	HI10500lb Hydraulic Winch	\$1219
19005	HI12000lb Hydraulic Winch	\$1399
19010	Hydraulic Winch Adapter Kit	\$79

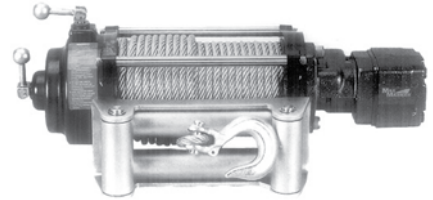

SI12000 winch

ELECTRIC WINCH

For those of you who prefer an electric winch, Mile Marker has you covered with a complete line of high quality, high powered electric winches. Count on the same consistent quality and performance you've come to expect from Mile Marker.

19112	SEC8000 Electric Winch	\$399
19124	SI 9500 Electric Winch	\$699
19132	SI12000 Electric Winch	\$749

WINCH ACCESSORIES

19150	Winch Accessory Kit	\$169
19155	HD Snatch Block	\$55
19160	Universal HD Roller Fairlead	\$65
19180	5/16" Winch Cable 100'	\$59
19185	3/8" Winch Cable 100'	\$7



WIPERS

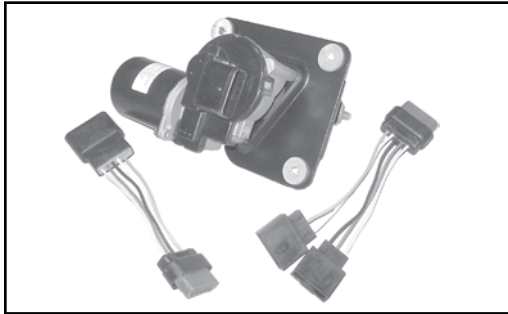

MECHANICAL PARTS

35200	Rebuilt Wiper Motor, 80-86	\$90
35202	New Wiper Motor, 87-96 W/2Plugs	\$55
35208	Windshield Wiper Mechanism, RH (used)	\$25
35209	Windshield Wiper Mechanism, LH (used)	\$25
35209B	Windshield Wiper Mech. Bushings, 80-86	\$6

WIPER BLADES ETC. . .

35205	Wiper Blade W/Refill, 80-96	\$7
35207	Wiper Arm, 80-90 (aftermarket)	\$18
35206	Wiper Arm, 91-97 (aftermarket)	\$17
35204	Sure Wipe Wiper Springs	\$10
35208	Trailblade Wiper Blade	\$9

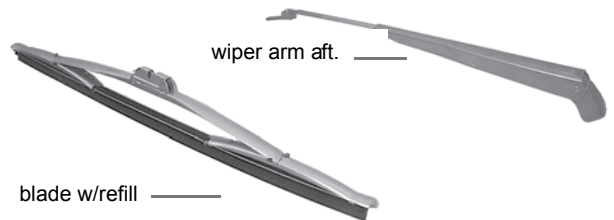

delay box



wiper switch



black knob

WIPER SWITCHES & KNOBS

35210	Switch W/O Delay Wipers	\$32
35212	Switch W/Delay Wipers	\$49
35217	Wiper Switch Knob (black)	\$12
35214	Delay Wiper Control Box	\$110

WASHER FLUID

35221	Solvent Bottle W/Coolant Tank	\$35
35222	Solvent Pump	\$15
35242	Solvent Squirt Nozzle, 80-86	\$12
35244	Solvent Squirt Nozzle, 87-91	\$15
35246	Solvent Squirt Nozzle, 92-96	\$15

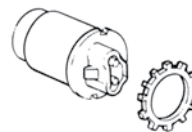

black sunvisor



arm & bracket

SUN VISOR ETC. . .

35230	Sun Visor, 80-86 (black) ea.	\$65
35232	Sun Visor, 80-86 (blue) ea.	\$65
35234	Sun Visor, 80-86 (red) ea.	\$65
35236	Sun Visor, 80-86 (tan) ea.	\$65
35240	Sun Visor Arm & Bracket	\$17

EMBLEMS

1980-86 EMBLEMS . . .

35100	"Bronco" Emblem, 80-86	\$30
35102	"Ranger" Emblem, 80-81	\$30
35103	"Custom" Emblem, 80-81	\$30
35104	"Lariat" Emblem, 80-86	\$45
35105	"Trailer Special" Emblem, 80-86	\$45
35106	"Camper Special" Emblem, 80-86	\$30
35109	"XL" Emblem, 82-86	Soon
35110	"XLT" Emblem, 82-86	\$15



BRONCO

MORE 1982-86 EMBLEMS . . .

35112	"F-150" Emblem, 80-81	\$35
35113	"F-350" Emblem, 80-81	\$35
35114	"F-350" Emblem, 80-81	\$35
35115	"F-100" Emblem, 82-84	\$35
35116	"F-150" Emblem, 82-84	\$35
35117	"F-250" Emblem, 82-84	\$35
35118	"F-350" Emblem, 82-86	\$35
35119	"4X4" Emblem, 80-86	Soon
35172	"FORD" Grill Emblem, 83-86	\$33
35171	Oval Tailgate Emblem	\$33

1987-91 EMBLEMS . . .

35120	"Bronco" Emblem, 87-91	\$39
35121	"Custom" Emblem, 87-91	\$23
35122	"XL" Emblem, 87-91	\$20
35123	"XLT" Emblem, 87-91	\$55

BRONCO

MORE 1987-91 EMBLEMS . . .

35125	"4X4" Emblem, 87-91	\$32
35126	"Camper Special", 87-91	\$20
35127	"Trailer Special" Emblem, 87-91	\$20
35128	"F-150" Fender Emblem, 87-91	\$20
35129	"F-250" Fender Emblem, 87-91	\$39
35130	"F-350" Fender Emblem, 87-91	\$39
35174	"FORD" Oval Grill Emblem, 87-96	\$34
37170	"BRONCO" Dash Emblem, 87-91	\$7.50
37171	"BRONCO XLT" Dash Emblem, 87-91	\$7.50

**92-96 EMBLEMS . . .**

35140	"XL" Nameplate, 95-96	\$35
35141	"XLT" Emblem, 92-96	\$45
35142	Eddie Bauer Emblem, 92-96	\$30
35143	"F-150 Custom" Emblem, 92-96	\$42
35144	"F-150 XL" Emblem, 92-96	\$42
35145	"F-150 XLT" Emblem, 92-96	\$42
35146	"F-250 Custom" Emblem, 92-96	\$42

**MORE 92-96 EMBLEMS . . .**

35147	"F-250 XL" Emblem, 92-96	\$42
35148	"F-250XLT" Emblem, 92-96	\$42
35149	"F-350 Custom" Emblem, 92-98	\$42
35150	"F-350XL" Emblem, 92-98	\$42
35151	"F-350 XLT" Emblem, 92-98	\$42
35152	"Flare Side" Emblem, 92-96	\$42
35175	"FORD" Oval Grill Emblem	\$33



STEERING COLUMN



STEERING COLUMN ELECTRICAL

37022	W/O Tilt Wheel, 1980-83	\$78
37023	W/Tilt Wheel, 1980-83	\$79
37024	W/O Tilt Wheel, 1984-91	\$60
37025	W/Tilt Wheel, 1984-91	\$69
37035	Turn Signal Lever, 1992-96	\$59
37018	Overdrive Shift Button, 1992-96	\$10

STEERING COLUMN MECHANICAL

37006	Auto Trans. Column Sleeve, W/O Tilt Wheel, 1981-91	\$30
37007	Auto Trans. Column Sleeve, W/Tilt Wheel, 1981-89	\$30
37009	Manual Trans. Column Sleeve, 1980-91	\$90
37012	Column Sleeve Bushing, 1980-91	\$5
37050	Shift Tube, 1992-96	\$30
37088	Ignition Actuator, 1989-91	\$12

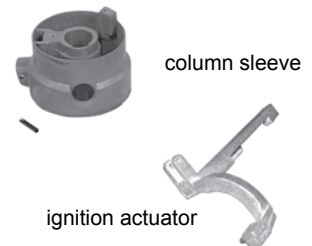

COLUMN BEARINGS

37060	Upper Bearing, 80-91 Bronco/PU	\$14
37061	Lower Bearing, 80-91 Bronco/PU	\$14
37062	Upper Bearing Bushing, 80-89 Bronco/80-91 PU	\$6
37063	Lower Bearing Bushing, 80-89 Bronco/80-91 PU	\$5
37070	Shift Rod Bushing, 80-91 Bronco/PU	\$4

FENDER FLARES



Quality aftermarket fender flares manufactured by Bushwacker®.

EXTEND-A-FENDER® FLARES

Bushwacker Extend-A-Fender flares. Extend the tire coverage of your truck approximately 1¾" with these good looking flares. Paint to match or accentuate your vehicle. Easy to install. Includes mounting hardware.

35730	Extend-A-Fender Flares, 87-91 Bronco/PU (front)	\$145
35731	Extend-A-Fender Flares, 87-91 Bronco/PU (rear)	\$145
35732	Complete Kit, 87-91 Bronco/PU (front & rear)	\$289
35734	Extend-A-Fender Flares, 92-96 Bronco/PU (front)	\$165
35735	Extend-A-Fender Flares, 92-96 Bronco/PU (rear)	\$165
35736	Complete Kit, 92-96 Bronco/PU (front & rear)	\$319



1992-96 cut out flare shown above

CUT-OUT® FENDER FLARES

Bushwacker Cut-Out flares are for use with extra large tires. Extends the amount of tire coverage to approximately 3"-3½". Black finish can be painted to match your existing color. Includes all mounting hardware. Sold in pairs.

35700	Cut-Out Flares, 80-86 Bronco/PU (front)	\$207
35702	Cut-Out Flares, 80-86 Bronco/PU (rear)	\$203
35710	Cut-Out Flares, 87-91 Bronco/PU (front)	\$219
35711	Cut-Out Flares, 87-91 Bronco/PU (rear)	\$219
35714	Cut-Out Flares, 92-96 Bronco/PU (front)	\$210
35715	Cut-Out Flares, 92-96 Bronco/PU (rear)	\$210

SOFT TOPS

FULL TOPS 80-91 BRONCO



Soft top above shown on 1979 Bronco. 80-91 Bronco top is similar in design and appearance.

New 80-91 soft top features diamond textured 20oz. marine grade vinyl. This new material is thicker and better quality than the previous vinyl material. In addition these tops have zip out side panels, and rear curtains which can be zipped out or rolled up. Installation requires much less drilling than older style tops. No drilling on the tailgate at all.

35600	Full Top, Black W/Tinted Windows	\$569
35605	Full Top, Denim Spice W/Tinted Windows	\$589

FASTBACK TOPS 80-91 BRONCO

For those of you who prefer the tonneau look Specialty Top Company's fastback top is for you. Includes a rear partition section separating the cargo area from the passenger compartment.

35612	Fastback Top Black W/ Tinted Windows	\$oon
-------	--------------------------------------	-------



Note: While these tops will fit 1992-96 Broncos, this application is not recommended. Installation on these model years will render rear seat belts and rear third brake light in-operable.

Check out our killer website at
www.Broncograveyard.com with
 over 300 pages of online content.
 Buy or sell your dream truck on the
 internets largest Bronco site.

HALF CAB CONVERSIONS

Coming soon!!!

Turn your Bronco into a Pick-up!!!



Convert your Bronco into a Pick-up with our half cab conversion kit!

Create a "custom" look for your Bronco with this unique conversion kit from JBG.

We are currently developing a tough, durable, easy to install (in an afternoon) half cab kit for 80-96 Broncos. These kits will be manufactured from high quality fiberglass and will feature an upper cab section with window opening (accepts rear window from 73-96 Pick-up), bulkhead, trim pieces and all materials required to transform your Bronco into an awesome short bed Pick-up (optional fiberglass cargo cover also available).



1/2 CAB CONVERSION KITS

35480	Half Cab Conversion W/Tonneau Cover	\$oon
35482	Half Cab Conversion W/Bulkhead	\$oon
35484	Tonneau Cover Only	\$oon
35486	Fiberglass Bulkhead	\$oon

RUBBER WEATHERSTRIP

SUPER WEATHERSTRIP KITS

Looking for superior quality weatherstripping at an awesome price. Check out these new *SuperWeatherstrip* kits from JBG! We make it easy by offering all of the commonly replaced weatherstrip in these *SuperWeatherstrip* kits. Step up to the highest quality lowest priced weatherstrip kits in the USA.



Bronco kit includes: Cab door seals, upper door seals, inner/outer door glass seals, door glass run, rear glass run, tailgate to bed seal, Inner & outer tailgate belts.

Pick-up kit includes: Rear window seal, cab door seals, upper door seals, inner/outer door glass seals, door glass run and vent seal kit.

SUPER WEATHERSTRIP KIT FOR TRUCKS

(W/BLACK REAR WINDOW SEAL)

SUPER WEATHERSTRIP KIT FOR BRONCOS

36022	Bronco Kit, 1980-86	\$280	36024	Pick-up Kit, 1980-86	\$180
36023	Bronco Kit, 1987-91	\$309	36025	Pick-up Kit, 1987-91	\$209
36023A	Bronco Kit, 1992-96	\$319	36026	Pick-up Kit, 1992-96	\$209

SUPER WEATHERSTRIP KIT FOR PICK-UPS

(W/PLASTIC CHROME REAR WINDOW SEAL)

36028	Pick-up Kit, 1980-86	\$180
36029	Pick-up Kit, 1987-91	\$209
36029A	Pick-up Kit, 1992-97	\$209

VENT WINDOW RUBBER

36007A	Vent Window Rubber (pair) Aft, 1980-86	\$50
36009	Vent Window Rubber, RH, OEM, 1987-91	\$92
36010	Vent Window Rubber, LH, OEM, 1987-91	\$92
36009A	Vent Window Rubber (pair) Aft, 1987-91	\$39
36011	Vent Window Rubber, RH, OEM, 1992-96	\$210
36012	Vent Window Rubber, LH, OEM, 1992-96	\$210
36013	Vent Window Rubber, (pair) Aft, 1992-97	\$39

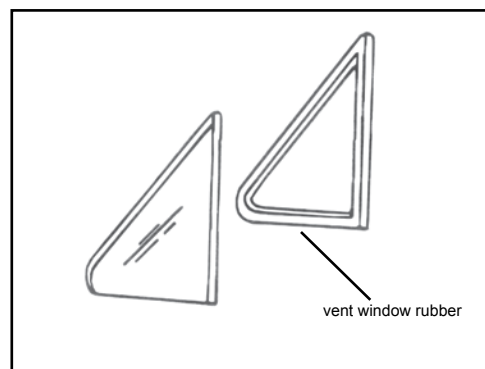

DOOR GLASS WEATHERSTRIP

Replace the old worn out weatherstrip on your truck with these high quality replacement parts from JBG. Complete kit includes inner & outer door glass weatherstrip and door frame glass run weatherstrip (6 pc.kit does both doors). Door glass weatherstrip kit includes inner & outer weatherstrip only (4pc.set). You can also purchase each piece individually if you like.

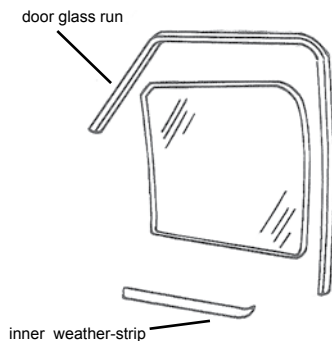

34395	Glass Weatherstrip Kit, Complete (6pc.) 1980-86	\$75
34396	Glass Weatherstrip Kit, Complete (6pc.) 1987-96	\$75
34394	Door Frame Glass Run, 1980-96	\$12
34386A	Door Glass Weatherstrip Kit (4pc.) 1980-86	\$45
34388A	Door Glass Weatherstrip Kit (4pc.) 1987-96	\$42

DOOR SEALS

Getting a little too much of the outside on the inside of your ride? Could be time to replace the door seals with these new units. One piece design.

36000	Door Seal, 80-96 Bronco/Pick-up Aft. (each)	\$20
36001	Door Seals, 80-96 Bronco/1980-96 OEM (pair)	\$100
36005	Top Door Rubber, 80-96 Bronco/Pick-up OEM (pair)	\$45
36006	Top Door Rubber, 80-96 Bronco,Pick-up Aft. (pair)	\$25

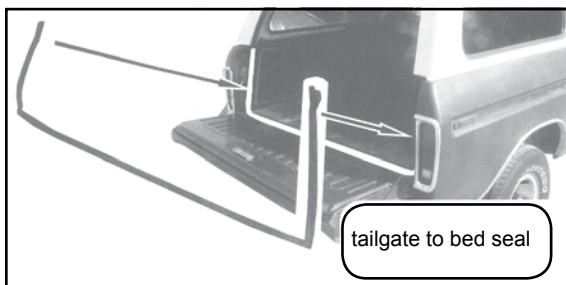
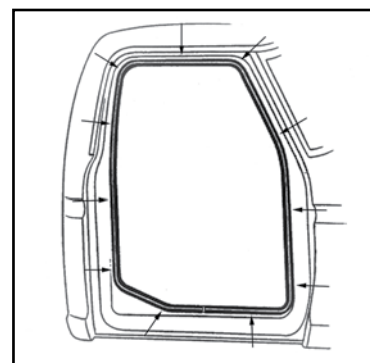
**TAILGATE TO BED SEAL**

36021	Tailgate To Bed Seal	\$45
-------	----------------------	------

REAR WINDOW SEALS

36033	Rear Window, Seal Plain, 1980-96 (aft.)	\$35
36034	Rear Window, Seal Plain, 1980-96 OEM	\$50
36035	Rear Window Seal, W/Groove, 1980-96 PU (aft.)	\$40

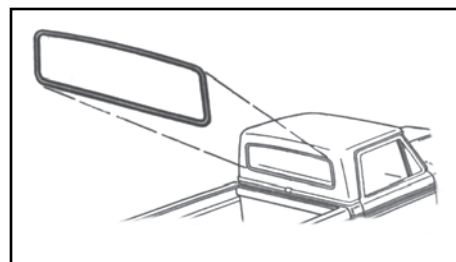

BRONCO TOP SEALS

Has your Bronco top been taken off and re-installed too many times. Help make it weather tight again with these new seals available at JBG.

36016	Front Top Weatherstrip	\$20
36018	Rigid Top Weatherstrip	\$25
36030	¼ Panel To Top Seal (RH)	\$29
36032	¼ Panel To Top Seal (LH)	\$29
36020	Rear Glass Run	\$39

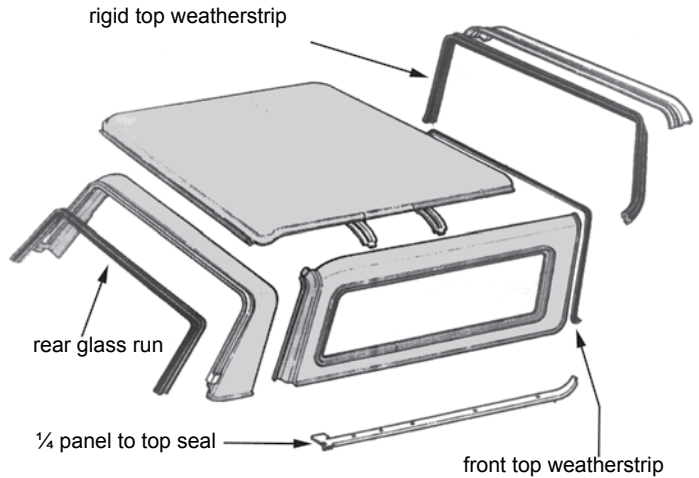

BRONCO TOP WINDOW GASKETS

36037	Top Window Seals, 80-96 (pair)	\$115
36038	Top Window Seal, 80-96, LH	\$60
36039	Top Window Seal, 80-96, RH	\$60

TAILGATE WEATHERSTRIP

34543	Inner & Outer Weatherstrip Belt Kit	\$55
34544	Weatherstrip End, RH, OEM	\$61
34544A	Wetherstrip End, RH, Aft	\$16
34545	Weatherstrip End, LH, OEM	\$61
34545A	Weatherstrip End, LH, Aft	\$16

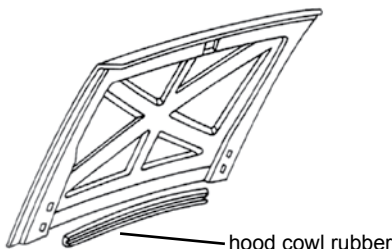
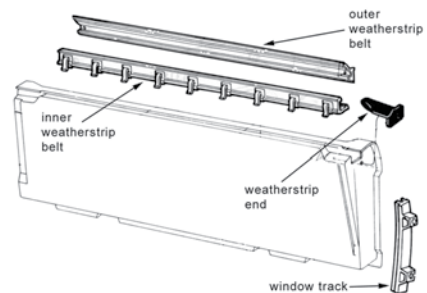

HOOD COWL RUBBER

36002A	Hood Cowl Rubber, 80-86, Aftermarket	\$35
36004A	Hood Cowl Rubber, 87-96, Aftermarket	\$35

PEDAL COVERS

Small pedal cover measures approximately 2¼" x 3¼" and was used on clutch pedal on 80-89 Bronco/PU. Large pedal cover measures 2¼" x 4¾" and was used on all 80-96 Bronco/Pick-up power brake pedals.

36050	Power Brake Pedal Cover, 80-96	\$5
36052	Clutch Pedal Cover, 80-89	\$5
36054	Park Brake Pedal Cover, 80-91	\$5
36055	Park Brake Pedal Cover, 92-97	\$4

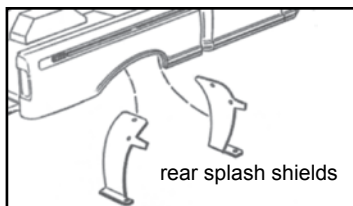
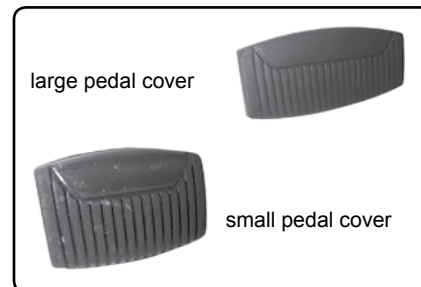
**SPLASH SHIELDS**

36060	Rear Wheel Splash Shields, 80-96 (ea.)	\$10
36062	Rear Wheel Splash Shields, 80-96 (set of 4)	\$39

OEM SHIFTER BOOTS

36070	Transfer Case Boot, 1980-86	\$145
36071	Transfer Case Boot, 1987	\$95
36072	Transfer Case Boot, 1988-91	\$65
36074	4 Spd. Shifter Boot, 1980-86	\$40

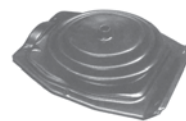
**AXLE BUMPERS**

36090	Front Axle Bumper, OEM, 1980-96	\$7
36093	Rear Axle Bumper, 1980-96	\$17
36094	Rear Axle Bumper, W/Auxiliary Springs, 1980-96	\$12

MISCELLANEOUS

36040	Clutch Rod Boot, 80-83 Bronco/PU	\$16
36042	Clutch Fork Boot, 80-83, 351M/400	\$15
36044	Clutch Fork Boot, 80-83, 300,302,351W	\$17
36045	Clutch Fork Boot, 84-92, 300,302,351W	\$24
36056	Park Brake To Floor Seal	\$8



DASHBOARD

1980-86 DASH COVER

Rejuvenate the life of your vehicle by installing one of these great looking dash covers. Coverlay dash covers are vacuum-molded from the original dash to give an original look and a perfect fit. Made from thick, durable ABS plastic. Will not crack under extreme hot or cold temperatures. Fits over your original dash for easy installation.



37101	Dash Cover, 80-86 (black)	\$105	37105	Dash Cover, 80-86 (dk. brown)	\$105
37102	Dash Cover, 80-86 (lt. blue)	\$105	37106	Dash Cover, 80-86 (red)	\$105
37103	Dash Cover, 80-86 (dk. blue)	\$105	37107	Dash Cover, 80-86 (gray)	\$105
37104	Dash Cover, 80-86 (lt. brown)	\$105	37108	Dash Cover, 80-86 (maroon)	\$105
			37109	Dash Cover, 80-86 (dk. green)	\$105



1987-96 DASH COVER

Same quality dash cover as above except designed to fit your 1987-91 Bronco/Pick-Up.

87-91 DASH COVER

37115	Cover, 87-91 (black)	\$95
37115LBL	Cover, 87-91 (lt. blue)	\$95
37115DBL	Cover, 87-91 (dk. blue)	\$95
37115LBR	Cover, 87-91 (lt. brown)	\$95
37115DBR	Cover, 87-91 (dk. brown)	\$95
37115RD	Cover, 87-91 (red)	\$95
37115DGR	Cover, 87-91 (gray)	\$95
37115MR	Cover, 87-91 (maroon)	\$95
37115GRN	Cover, 87-91 (dk. green)	\$95

92-96 DASH COVER

37117	Cover, 92-96 (black)	\$105
37117DBL	Cover, 92-96 (dk. blue)	\$105
37117DBR	Cover, 92-96 (dk. brown)	\$105
37117DGR	Cover, 92-96 (dk. gray)	\$105
37117GRN	Cover, 92-96 (green)	\$105
37117LBL	Cover, 92-96 (lt. blue)	\$105

1980-86 OEM DASH PAD

Complete OEM dash pad. Made with original Ford tooling.

37100	OEM Dash Pad, 80-86, Black	\$325
-------	----------------------------	-------



DASHBOARD BRACET REPAIR

Fix that rattling noise that is coming from the right side of the dash. Replace your original plastic dash bracket with this new metal bracket. Come complete with bracket, mounting hardware and instructions.



371190 Dash Bracket Repair Kit, RH, 92-96 \$25

HEADLIGHT SWITCH

37134	Headlight Switch, 1980 Bronco/Pick-Up	\$12
37135	Headlight Switch, 81-86 Bronco/Pick-Up	\$12
37137	Headlight Switch, 87-96 Bronco/Pick-Up	\$12
37137A	Headlight Switch, 90-97	\$12
37136	Headlight Switch Knob, 1980-96	\$13

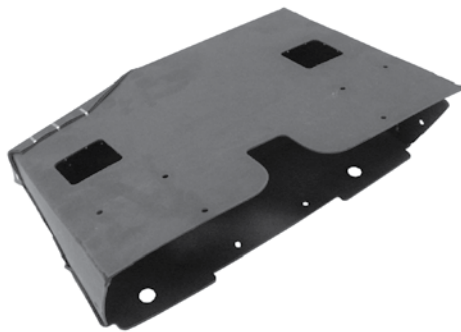
**GLOVE BOX**

37144	Glove Box, 1980-86 No/AC	\$15
37145	Glove Box, 1980-86 W/AC	\$33
37150	Glove Box Cylinder & Key, 1980-86	\$40

LIGHTER & ASHTRAY

37151	Cigarette Lighter Knob W/Element	\$10
37152	Cigarette Lighter Socket	\$15
37155	Ashtray (used)	\$10

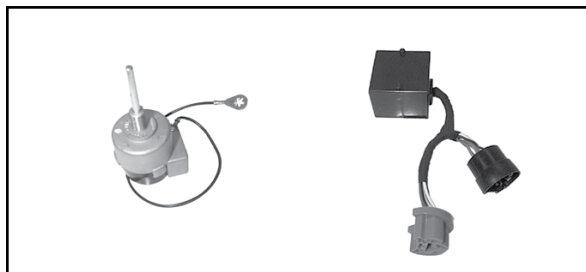
**WIPER SWITCH**

37130	Wiper Switch, 1980-91	\$32
37132	Wiper Switch W/Delay, 1980-91	\$49
37133	Wiper Switch Knob, 1980-96	\$12
35214	Wiper Delay Box	\$110

IGNITION

37156	Ignition Switch, 80-91	\$10
37157	Ignition Switch, 92-96	\$18
37082	Ign. Cylinder & Keys, 80-91	\$10
37084	Ign. Cylinder & Keys, 80-91 (w/pigtail)	\$10
37086	Ign. Cylinder & Keys, 92-96	\$18

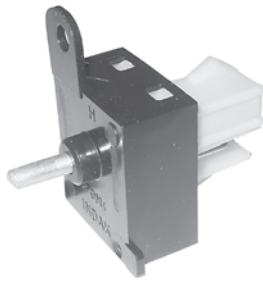
**BLOWER MOTOR SWITCH**

37278	Heat Blower Switch, 80-91	\$19
37279	Heat Blower Switch, 92-96	\$19
37218	Blower Motor Resistor, 80-96	\$18
37219	Blower Motor Pigtail, 86-94	\$10

BRAKE LIGHT SWITCH

37165	Brake Light Switch, 80-85	\$5
37166	Brake Light Switch, 86-88	\$5
37167	Brake Light Switch, 89-93	\$5
37168	Brake Light Switch, 94-96	\$5

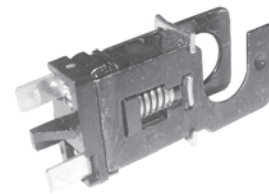
**MISCELLANEOUS DASH PARTS**

37163	Fog Light Switch, 88-97	\$28
27118	Constant Voltage Regulator, 80-86	\$39

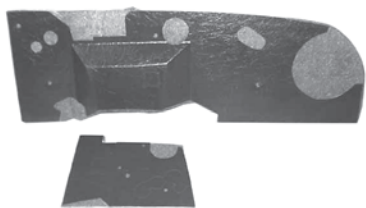
**FIREWALL INSULATION**

Firewall insulator is molded like factory original. Featuring a PVC plastic front and comes complete with under-dash piece and firewall piece. Includes attaching hardware.

37197 Firewall Insulation, No AC, 1980-96 \$149

INSTRUMENT CLUSTER LENS

37122	Instrument Cluster Lens, 80-86	\$26
37123	Instrument Cluster Lens, 87-91	\$26
37124	Instrument Cluster Lens, 92-96	\$32

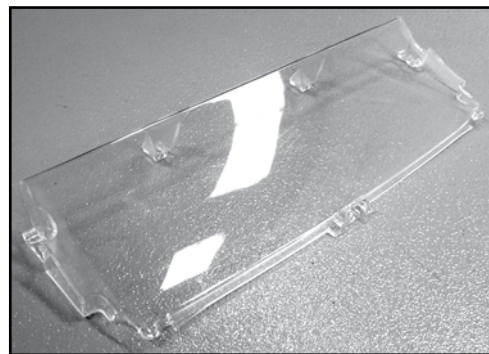
**DASHBOARD RADIO PANEL**

These trim panels are replacements for the radio/clock area trim panels.

371800	80-81, Black W/Radio, No Clock	\$oon
371801	82-83, Black, No Radio, No Clock	\$oon
371802	82-83, Black, W/Radio, No Clock	\$oon
371803	85-86, Metallic Finish, W/Radio, No Clock	\$oon
371810	82-84, Woodgrain, No Radio, No Clock, No Nameplate	\$oon
371811	82-84, Woodgrain, W/Clock, W/Radio, No Nameplate	\$oon
371812	82-84, Woodgrain, No Radio, No Clock, W/Nameplate	\$oon
371813	82-84, Woodgrain, W/Radio, W/Clock, W/Nameplate	\$oon
371814	85-86, Woodgrain, W/Radio, W/Clock, W/Nameplate	\$oon
371815	85-86, Woodgrain, No Radio, No Clock, W/Nameplate	\$oon
371816	85-86, Woodgrain, No Clock, No Radio, No Nameplate	\$oon
371817	85-86, Woodgrain, W/Radio, No Clock, W/Nameplate	\$oon

BRONCO CARPET AND MAT

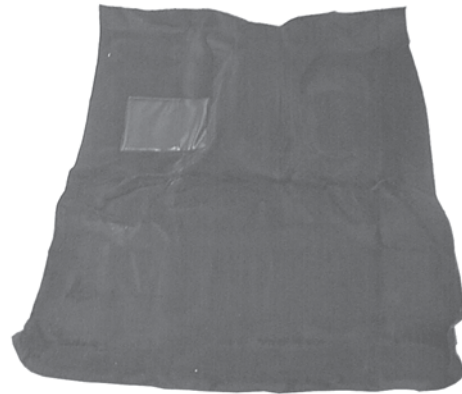

1980-96 BRONCO CARPET KITS

Our carpet kits are manufactured by Auto Custom Carpets. The worlds leading manufacturer of automotive floor coverings. Popular stock colors for specific model years are listed below however, all carpet kits are designed to fit 80-96 Broncos. Carpet is available as a complete kit (covers front section, rear section and wheel tubs) front section only or rear section only. Matching 4 piece floor mat kits also available.

Note: All shifter, seat track, and seat belt holes must be cut by installer.

376XX	Complete Carpet Kit	\$279
376XX	Front Section Carpet	\$162
376XX	Rear Section Carpet	\$185
376XX	4 Piece Floor Mat Kit	\$86

	<i>Year</i>	<i>Complete</i>	<i>Front</i>	<i>Rear</i>	<i>Floor Mat Kit</i>
Black	1980-96	Part #37600	Part #37610	Part #37620	Part #37670
Dk. Gray	1983-95	Part #37601	Part #37611	Part #37621	Part #37671
Oxblood	1980-96	Part #37602	Part #37612	Part #37623	Part #37673
Maple/Canyon	1980-96	Part #37603	Part #37613	Part #37622	Part #37672
Crystal Blue	1980-95	Part #37604	Part #37614	Part #37624	Part #37674
Desert Tan	1982-90	Par #37605	Part #37615	Part #37625	Part #37675
Taupe	1980-96	Part #37605A	Part #37615A	Part #37625A	Part #37675A
Mocha	1992-96	Part #37605M	Part #37615M	Part #37625M	Part #37675M
Regatta Blue	1980-96	Part #37606	Part #37616	Part #37626	Part #37676
Graphite	1980-96	Part #37607	Part #37617	Part #37627	Part #37677

TRUCK CARPET

Auto custom carpets puts the same high quality and features from the Bronco carpet into their truck carpet as well. The kits listed below are for Black carpet kits only. Other colors are available. Please call for pricing and availability.

37800	80-96 4wd Reg. Cab	\$135	37854	87-96 4wd Reg Cab Elec. T-Case	\$135
37800A	80-96 2wd Reg. Cab	\$135	37856	87-96 4wd Ext. Cab	\$159
37815	80-86 4wd Ext. Cab	\$135	37858	87-96 4wd Ext. Cab, 4spd	\$159
37815A	80-86 2wd Ext. Cab	\$135	37860	87-96 4wd Ext Cab Elec. T-Case	\$159
37835	80-86 4wd Crew Cab	\$135	37862	87-96 4wd Crew Cab	\$175
37835A	80-86 2wd Crew Cab	\$135	37864	87-96 4wd Crew Cab, 4spd	\$175
37850	87-96 4wd Reg. Cab	\$135	37866	87-96 4wd Crew Cab, Diesel	\$175
37851	87-96 2wd Reg. Cab	\$135	37868	87-96 4wd Crew Cab, Diesel, 4spd	\$175
37852	87-96 4wd Reg Cab W/4spd	\$135	37870	87-96 4wd Crew Cab, Elec. T-Case	\$175
37853	87-96 2wd Reg Cab W/4spd	\$135			

TRUCK VINYL FLOOR COVERS

These vinyl floor covers combine good looking durability with easy clean-up. Pre-molded and made from long lasting heavy duty materials. The kits listed below are for Black vinyl floor covers only. Other colors available. Please call for pricing and availability.

37810	80-86 4wd Reg. Cab	\$165	37876	87-96 4wd Reg Cab	\$165
37810A	80-86 2wd Reg Cab	\$165	37877	87-96 2wd Reg Cab, 4spd	\$165
37825	80-86 4wd Ext. Cab	\$185	37878	87-96 4wd Reg Cab, Elec. T-Case	\$165
37845	80-86 4wd Crew Cab	\$205	37880	87-96 4wd Ext Cab	\$185
37845A	80-86 2wd Crew Cab	\$205	37883	87-96 2wd Ext Cab	\$185
37874	87-96 4wd Reg Cab	\$165	37888	87-96 4wd Crew Cab	\$205
37875	87-96 2wd Reg Cab	\$165	37887	87-96 2wd Crew Cab	\$205

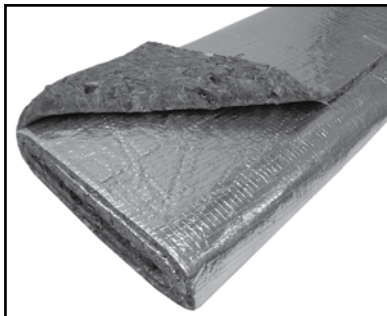
**INSULATION PAD**

Protect against heat, sound, vibration and air flow with this thermal-acoustic insulation pad. Gives you a durable, long lasting, radiant heat barrier that provides up to 50% better R-values than other reflective insulation materials. Fire retardant. Meets motor vehicle safety standards (FMVSS 302) Includes one foil sided 4' x 6' insulation pad.

37685	Insulation Pad	\$29
-------	----------------	------

HUSH MAT

HUSH MAT ULTRA

Hush Mat Ultra sheets are formulated with a thin but dense, visco-elastic polymer sound deadener to reduce distorting vibration and noise over a wide temperature and sound frequency range. HushMat Ultra, through its proprietary chemistry provides outstanding damping performance for firewall, floor, doors, roof, hood, wheel wells, trunk floor and quarter panel application.

977100	License Plate Kit, (1) 4" X 12" Pad	\$14
977120	Speaker Kit, Silver, 2 Sq Ft.	\$24
977122	Speaker Kit, Black, 2 Sq Ft.	\$24
977200	Starter Kit, Silver, 4 Sq Ft.	\$35
977202	Starter Kit, Black, 4 Sq Ft.	\$35
977210	Door Kit, Silver, 10 Sq Ft.	\$75
977212	Door Kit, Black, 10 Sq Ft.	\$75
977220	Trunk Kit, Silver, 19 Sq Ft.	\$135
977222	Trunk Kit, Black, 19 Sq Ft.	\$135

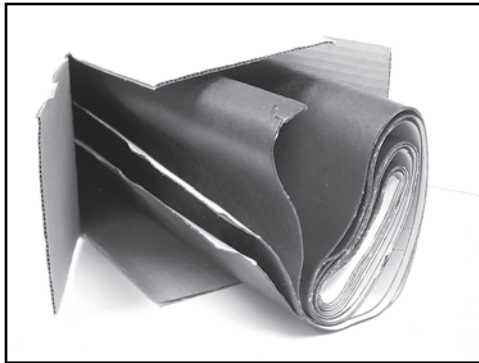
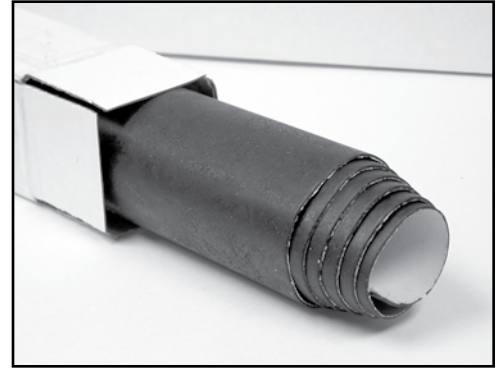

MORE HUSH MAT ULTRA

977230	Cargo Kit, Silver, 31 Sq Ft.	\$220
977232	Cargo Kit, Black, 31 Sq Ft.	\$220
977240	Front Floor Kit, Silver, 39 Sq Ft.	\$240
977242	Front Floor Kit, Black, 39 Sq Ft.	\$240
977250	Bulk Kit, Silver, 58 Sq Ft.	\$345
977252	Bulk Kit, Black, 58 Sq Ft.	\$345
977260	Hoodliner Kit, Silver, 12 Sq Ft.	\$86

MORE HUSH MAT PRODUCTS

977300	Silencer Foam, 3mm Thick, (2) 23" X 36" Sheets	\$125
977310	Silencer Foam, 8mm Thick, (2) 23" X 36" Sheets	\$179
977320	Silencer Foam, 13mm Thick, (4) 12" X 23" Sheets	\$165
977500	Hush Mat Quiet Tape, (5) 2" X 6" Strips	\$19
977502	Hush Mat Quiet Tape, 1" X 30' Roll	\$30
977550	Hush Mat Ultra H ₂ O Seam Seal	\$30





1980-96 BRONCO VINYL FLOOR COVERS

These vinyl floor covers combine good looking durability with easy clean-up. Manufactured by Auto Custom Carpets, vinyl floor covers are pre-molded and made from long lasting heavy duty materials. Available as a complete kit (front section, rear section and wheel tubs) front section only or rear section only. Colors and prices are listed in the chart below.

	<u>YEAR</u>	<u>COMPLETE KIT</u>	<u>FRONT SECTION</u>	<u>REAR SECTION</u>
<u>BLACK</u>	1980-96	Part #37640 - \$295	Part #37645 - \$179	Part #37650 - \$189
<u>GRAY</u>	1980-96	Part #37641 - \$309	Part #37646 - \$179	Part #37651 - \$209
<u>BEIGE</u>	1980-96	Part #37642 - \$309	Part #37647 - \$179	Part #37652 - \$209

THRESHOLD MOLDINGS



37690	Threshold 80-96 Bronco/Pick-up RH (black)	\$30
37691	Threshold 80-96 Bronc/Pickup LH (black)	\$30
3769	Tailgate Threshold Molding (Bronco)	\$45

DIESEL PARTS

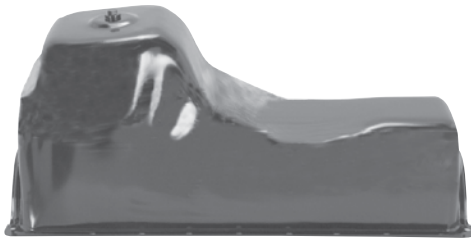

ENGINE PARTS

30075	Exhaust Manifold, LH, 7.3L Diesel	\$125
30076	Exhaust Manifold RH, 7.3L Diesel	\$125
30194	Oil Pan, 83-94, 6.9L/7.3L Diesel	\$120
30195	Oil Pan, 94-97, 7.3L Diesel	\$120



PULLEYS

30449	PS Pump Pulley, 94-97 Diesel	\$20
30482	AC Bypass Pulley, 93-97 Diesel	\$25

RADIATORS

30635	88-94 Diesel, W/O AC, W/O AOD	\$369
30636	88-94 Diesel, W/AC	\$369
30637	95-97 Diesel, All	\$279

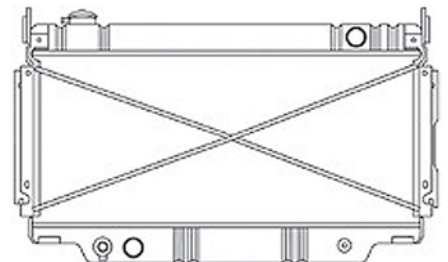

MISCELLANEOUS

30797	Throttle Position Sensor, 96-97 7.3L Diesel	\$39
702810	Injector O-Ring Kit, 94-03 7.3L	\$9
702820	Injector O-Ring Kit, 94-03 7.3L (OE# F4TZ-9F538-A)	\$9

WE ALSO CARRY A LARGE SELECTION OF 1998-2008 SUPERDUTY PARTS.
PLEASE CALL FOR YOUR SPECIFIC APPLICATION.

CORBEAU SEATS

CORBEAU BAJA SS

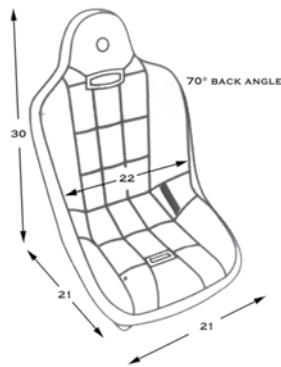

The heavily padded Baja SS suspension seat provides off-road drivers with the ultimate in support. **Standard features include:** Powder coated steel frames, reinforced nylon inner laced with military grade suspension chords, full body support and 5 point harness capable. Designed to fit up to a 34"-36" waist. (Baja SS Ultra is 4" taller and 1" wider to accommodate a 36"-38" waist. Wide version accommodates waist sizes 40"-42")

18704	Baja SS (black vinyl center)	\$179
18704G	Baja SS (gray vinyl center)	\$179
18704T	Baja SS (tan vinyl center)	\$199
18705	Baja SS (black tweed center)	\$179
18705G	Baja SS (gray tweed center)	\$179
18705T	Baja SS (tan tweed center)	\$199
18706Y	Baja SS (yellow cloth center)	\$199
18706B	Baja SS (blue cloth center)	\$199
18706R	Baja SS (red cloth center)	\$199
18720	Baja SS Ultra Black (black tweed center)	\$229
18722	Baja SS Ultra Black Wide (black tweed center)	\$259
18720G	Baja SS Ultra Gray (gray tweed center)	\$229
18722G	Baja SS Ultra Wide (gray tweed center)	\$259
37510	Baja SS Seat Adapter Bracket	\$25

CORBEAU FORZA.

The ever popular Forza provides racers with a full suspension seat at an unbeatable price. **Standard features include:** Tubular steel frame, injection molded foam, integrated full body support, 5 point harness capability and leatherette high wear patches. The Forza II incorporates all of the Forza's features into the largest racing seat available today. (Forza II will accommodate up to a 44" waist).

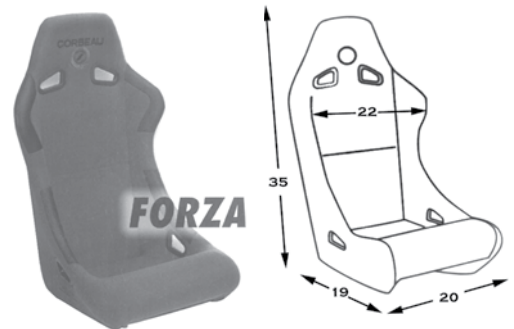

18760V	Corbeau Forza (black vinyl)	\$229	18770	Corbeau Forza II (black cloth)	\$259
18760	Corbeau Forza (black cloth)	\$229	18772	Corbeau Forza II (blue cloth)	\$259
18766	Corbeau Forza (yellow cloth)	\$229	18774	Corbeau Forza II (red cloth)	\$259
18762	Corbeau Forza (blue cloth)	\$229			
18764	Corbeau Forza (red cloth)	\$229			



GTS II

The extremely comfortable GTS II is the perfect seat for the everyday driver. This heavily padded seat features deep side and lateral bolsters. Features include: high density injection molded foam, orthopedic design, adjustable headrest, and a fully adjustable seat back with a flip forward fingertip controlled lever for rear access. Fits up to a 38" waist.

18860	GTS II (black cloth)	\$349
18862	GTS II (grey cloth)	\$349
18864	GTS II (black leather)	\$575

TRS

The heavily padded TRS provides extreme comfort and support for drivers of all kinds. Standard features include: high-density injection molded foam, ergonomical design, harness belt capability, integrated shoulder, kidney and thigh support, and a fully adjustable seat back with a flip forward fingertip controlled lever for rear access. Will fit up to 42" waist.

18830	Corbeau TRS (black cloth)	\$349
18832	Corbeau TRS (gray cloth)	\$349
18830W	Corbeau TRS Wide (black cloth)	\$399

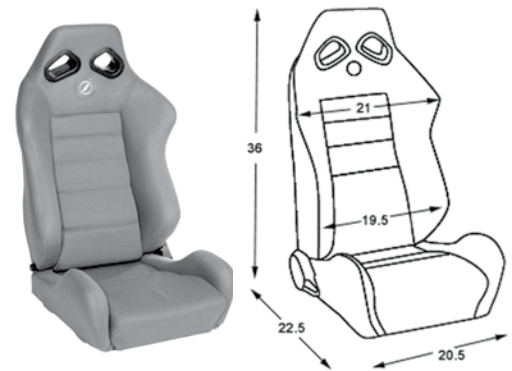

CORBEAU CR1

The CR1 provides drivers of all kinds with the latest in looks, comfort, durability and style. **Standard features include:** High density injection molded foam, ergonomical design, harness capability, integrated shoulder, kidney and thigh support, leatherette high wear patches, and a fully adjustable flip forward seat back for rear access. Designed for 34"-36" waist.

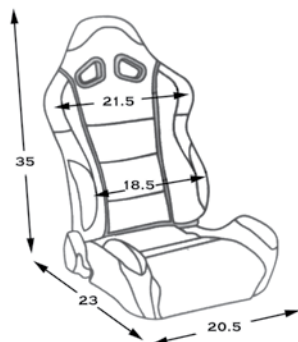

18820	CR1 Seat (black cloth)	\$399
18822	CR1 Seat (blue cloth)	\$399
18824	CR1 Seat (gray cloth)	\$399
18826	CR1 Seat (red cloth)	\$399
18828	CR1 Seat (yellow cloth)	\$399
18820W	CR1 Wide (black cloth)	\$449
18822W	CR1 Wide (blue cloth)	\$449
18824W	CR1 Wide (gray cloth)	\$449
18826W	CR1 Wide (red cloth)	\$449
18828W	CR1 Wide (yellow cloth)	\$449

CORBEAU SPORT

The Sport Seat is designed for the everyday driver. Its extra firm memory foam conforms to your body giving you extreme comfort along with the look of luxury. Standard features include: high density injection molded foam, orthopedic design, adjustable head-rest, and a fully adjustable seat back with a flip forward fingertip controlled lever for rear access. The Sport Seat will fit up to a 38" waist.

18870	Sport Seat (black vinyl)	\$320
18880	Sport Seat (gray vinyl)	\$320
18872	Sport Seat (black cloth)	\$320
18882	Sport Seat (gray cloth)	\$320
18874	Sport Seat (black vinyl/cloth)	\$320
18886	Sport Seat (gray vinyl/cloth)	\$320

**CORBEAU SEAT TRACKS FOR BRONCOS**

37511	Corbeau Seat Track LH 1980-88 Bronco	\$78
37512	Corbeau Seat Track RH 1980-88 Bronco	\$78
37513	Corbeau Seat Track LH 1989-95 Bronco	\$78
37515	Corbeau Seat Track RH 1989-95 Bronco (no flip)	\$78

**CORBEAU SEAT TRACKS FOR TRUCKS WITH BENCH SEAT**

These Corbeau seat tracks are designed to fit vehicles originally equipped with a bench seat.



37516	1980-82 Bench Bracket (for 2 seats)	\$150
37517	1983-95 LH Sliding Track	\$78
37518	1983-95 RH Sliding Track	\$78
37519	1983-95 Bench Bracket (for 2 seats)	\$150
37526	1993-95 Crew Cab Bench Bracket (for 2 seats)	\$155



CORBEAU SEAT TRACKS FOR TRUCKS WITH BUCKET SEATS

These Corbeau seat tracks are designed to fit vehicles originally equipped with bucket seats.

37520	83-95 F100-350 LH	\$78	37527	93-95 Crew Cab LH	\$78
37521	83-95 F100-350 RH	\$78	37528	93-95 Crew Cab RH	\$78
37522	83-91 Crew Cab LH	\$78	37529	93-95 Regular Cab LH	\$78
37523	83-91 Crew Cab RH	\$78	37530	93-95 Regular Cab RH	\$78
37524	92-96 Ext. Cab LH	\$78			
37525	92-96 Ext. Cab RH	\$78			

5 POINT COMPETITION HARNESS



Corbeau Competition Belts have been tested to meet and exceed all SFI 16.1 standards. Corbeau 5-Point Harness Systems feature state of the art Cam-Lock quick-release technology, military grade nylon webbing, extra strength computerized stitching, lightweight length adjusters, bolt-in & wrap around mounting hardware, optional 3-inch harness pads and the latest in style and design.

18990	5 Point Competition Harness (black)	\$149
18992	5 Point Competition Harness (purple)	\$149
18994	5 Point Competition Harness (red)	\$149

4 POINT HARNESS

4 point bolt-in style is designed to be anchored in four separate locations. Standard features include military grade nylon webbing with custom Corbeau Racing embroidery, pressure-reducing waist pads, and a push-button release system for easy disengagement. Your choice of black, blue, red or yellow.

18981	4 Point Bolt-In Harness (black)	\$79
18981B	4 Point Bolt-In Harness (blue)	\$79
18981R	4 Point Bolt-In Harness (red)	\$79
18981Y	4 Point Bolt-In Harness (yellow)	\$79





3 POINT HARNESS

3 point bolt-in style has same standard features as 4 point style above and provides you with the latest technology, design, and safety. Available in black, blue, red, or yellow.

18980	3 Point Harness (black)	\$79
18980B	3 Point Harness (blue)	\$79
18980R	3 Point Harness (red)	\$79
18980Y	3 Point Harness (yellow)	\$79

3 POINT DOUBLE RELEASE HARNESS

This 3 point double release harness is comprised of our 3 point harness above with an extra release buckle behind the seat. This feature provides easy access to the rear seat by allowing you to disconnect the rear strap. Available in black, blue, red or yellow.

18982	3 Point Double Release Harness (black)	\$89
18982B	3 Point Double Release Harness (blue)	\$89
18982R	3 Point Double Release Harness (red)	\$89
18982Y	3 Point Double Release Harness (yellow)	\$89



3 POINT RETRACTABLE HARNESS

The all-new Corbeau Retractable Harness Belt provides drivers the full movement capability of an everyday driving OEM belt. With the simple turn of knob, these retractable belts instantly restrict movement and provide the support and safety of race application.



18983	Retractable 3 Point Harness (black)	\$105
18983B	Retractable 3 Point Harness (blue)	\$105
18983R	Retractable 3 Point Harness (red)	\$105
18983Y	Retractable 3 Point Harness (yellow)	\$105

HARNESS PADS

Looking for a little more comfort from your harness? These harness pads look great and put some extra padding between you and the belt. Available in black, blue, red or yellow.

18996	Corbeau Harness Pads (black)	\$15
18996B	Corbeau Harness Pads (blue)	\$15
18996R	Corbeau Harness Pads (red)	\$15
18996Y	Corbeau Harness Pads (yellow)	\$15



CONSOLES & SECURE STORAGE



Looking for someplace safe & secure to stow your valuables while your away from the vehicle? These Tuffy Security Products are made to withstand a lifetime of abuse. Every part is carefully hand crafted with heavy duty 16 gauge steel using state of the art computerized machines with tolerances no more than five thousandths of an inch. Each piece then gets finished with an electronically fusion-bonded epoxy powder coat.

SERIES II CENTER CONSOLE

Manufactured by Tuffy Security Products. The best consoles on the market. Complete with built in drink holders, padded armrest, and removable inner tray. Dimensions: 24"L X 12-1/2"W X 18-1/2"H.

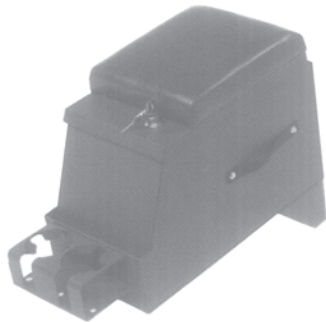

39780	Series II Center Security Console (black)	\$219
39781	Series II Center Security Console (light gray)	\$229
39782	Series II Center Security Console (charcoal)	\$229
39783	Series II Center Security Console (spice)	\$229
39784	Series II Center Security Console (light tan)	\$229

DELUXE STEREO CENTER CONSOLE

Deluxe stereo center console has all of the features of the Series II console but also includes a mount for your stereo unit. Helps keep your stereo safe and secure.

39790	Deluxe Center Security Console (black)	\$235
39791	Deluxe Center Security Console (light gray)	\$245
39792	Deluxe Center Security Console (charcoal)	\$245
39793	Deluxe Center Security Console (spice)	\$245
39794	Deluxe Center Security Console (tan)	\$245

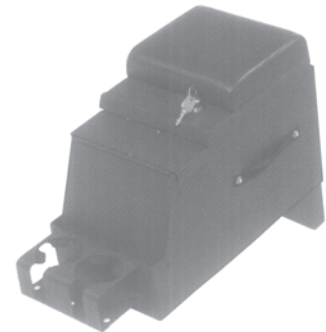

REAR CARGO TRUNK

Mounted behind the rear seat. The storage trunk is perfect for those wanting both options of carrying rear passengers and having lockable storage for your gear. (9-5/8" L X 33-7/8" W X 11-3/8" H)

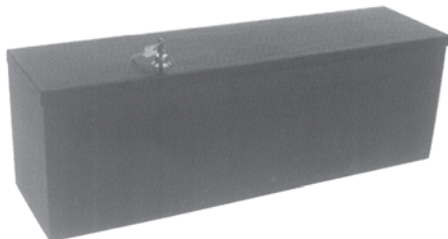

39772	Super Security Storage Trunk (black)	\$292
39773	Super Security Storage Trunk (charcoal)	\$295
39774	Super Security Storage Trunk (light gray)	\$295
39775	Super Security Storage Trunk (tan)	\$295

HOOD PARTS



HOOD RELEASE

34640	Hood Release Handle & Cable, 80-86	\$72
34641	Hood Release Handle & Cable, 87-91	\$75
34642	Hood Release Handle & Cable, 92-96	\$79

HOOD LATCH

34645	Hood Latch (used)	\$15
34646	80-81 Hood Latch	\$160
34647	82-86 Hood Latch	\$60
34648	87-96 Hood Latch	\$30

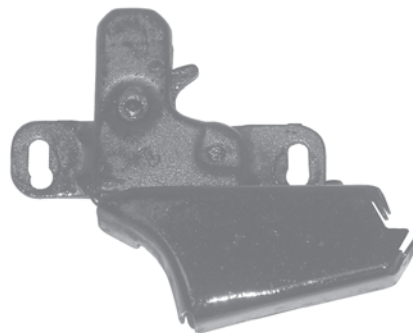

80-96 hood hinge

HOOD HINGE

34656	80-96 RH	\$20
34658	80-96 LH	\$20

HOOD SUPPORT

34674	80-96 RH	\$40
34676	80-96 LH	\$40



80-96 hood support

ROLL BARS & ACCESSORIES

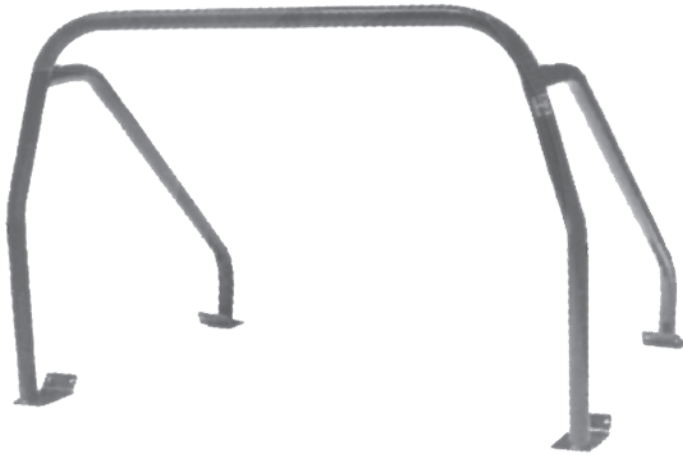

SPORT BAR ROLL CAGES

Constructed of 2" X .120" wall tubing, these cages are the best roll bar protection we offer. Available in 4pt.(pictured) or 6 pt. (includes front cage kit) configurations.

37700	4 pt. Roll Cage*, 80-96	\$300
37701	4 pt. Roll Cage*, 80-96 Welded	\$349
37720	6 pt. Roll Cage*, 80-96	\$493
37721	6 pt, Roll Cage*, 80-96 Welded	\$605

FAMILY BAR ROLL CAGES

Family bar cages extend their protection rearward to include the rear passengers. Constructed of 2" X .120 wall tubing, these cages provide superior protection. Available in 4 pt.(pictured) or 6 pt.(includes front cage kit) configurations. Shipped unassembled and unpainted.

37705	4 pt. Family Cage*, 80-96	\$435
37706	4 pt. Family Cage*, 80-96 Welded	\$515
37725	6 pt. Family Cage*, 80-96	\$715
37726	6 pt. Family Cage*, 80-96 Welded	\$959



STAINLESS STEEL ROCKER PANELS

Complete lower body trim set. Stainless steel trim set features polished mirror finish. 3M adhesive attached to back of panels allows for easy installation.

35500	Trim Set, 80-86 Bronco	\$109
35505	Trim Set, 87-91 Bronco	\$109
35508	Trim Set, 92-96 Bronco	\$109
33510	Trim Set, 80-86 PU 6' Box	\$129
33512	Trim Set, 87-91 PU 6' Box	\$129
33515	Trim Set, 80-86 PU 8' Box	\$135
33517	Trim Set, 87-91 PU 8' Box	\$135

*These items are either too heavy or too large to be shipped through our regular ground carrier (FedEx, UPS etc. . .) and must be shipped via truck freight. Please call for specific shipping prices.

ELECTRICAL

BATTERY TRAY



38020	Battery Tray, 80-86, RH	\$45
38020B	Battery Tray Support Bracket, 80-86	\$35
38021	Battery Tray, 87-96 RH	\$76
38022	Battery Tray, 87-96 LH	\$70
38015	Battery Hold Down Kit, 80-91	\$20.50
38017	Battery Hold Down Kit, 92-96	\$7

STARTER SOLENOID

38042	Starter Solenoid, 80-85	\$8
38044	Starter Solenoid, 86-96	\$8

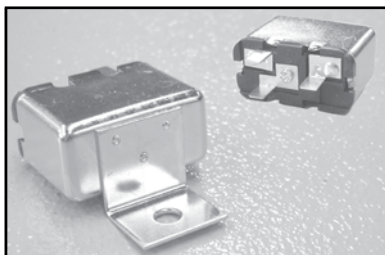

80-86 horn relay

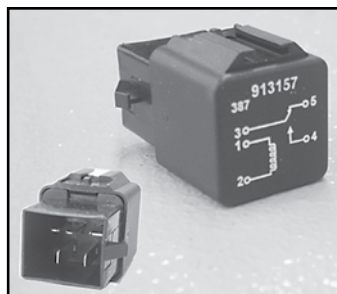

86-91 fuel pump relay

RELAYS

18045	Horn Relay, 80-86	\$12
38060	Horn Relay, 89-94	\$10
38061	Fuel Pump Relay, 86-91	\$10
38062	Fuel Pump Relay, 92-96	\$10
38063	Fog Light Relay, 93-94	\$10
38065	ABS Control Relay, 93-96	\$10

SOCKETS & PIGTAILS



1980-96 SOCKETS & PIGTAILS

38100	80-86 Front Park Light Socket	\$8	38180	80-90 Voltage Reg. Pigtail	\$7
38101	87-91 Front Park Light Socket	\$8	38182	82-94 Internal Volt Reg.	\$10
38102	92-96 Front Park Light Socket	\$8	38190	81-89 Washer Fluid Sensor	\$7
38105	80-86 Rear Brake Light Socket	\$7	38192	Wiper Switch Pigtail	\$16
38106	87-96 Rear Brake Light Socket	\$8	38128	80-91 Dimmer Switch	\$4
38107	80-96 Back-Up Light Socket	\$7	38130	83-94 EEC-IV Test Plug	\$15
38109	80-96 Side Marker Light Socket	\$3	38132	83-96 6 Way Elec. Module	\$15
38120	83-96 A/C Cycling Switch Pigtail	\$16	38134	80-95 Coolant Temp	\$10
38122	83-96 Air Charge Temp Sensor	\$10	38136	90-94 E40D Trans Shift	\$30
38124	93-95 Crank Position Sensor	\$63	38138	80-95 Bosch Fuel Injector	\$15
38162	80-91 Ign. Switch Pigtail	\$6	38140	83-97 Center Slot Injector	\$11
38164	92-96 Ign. Switch Pigtail	\$12	38142	83-97 W/O Center Slot Injector	\$7
38166	90-96 Trans Lever Switch Pigtail	\$15	38144	85-90 Fuel Pump Harness	\$7
38168	84-96 MAP Sensor Pigtail	\$11	38146	87-96 Headlight Switch Pigtail	\$10
38170	90-96 Neutral Safety Switch	\$31	38147	80-86 Headlight Pigtail	\$4
38171	86-90 3 Wire O2 Sensor Pigtail	\$13	38148	87-96 Headlight Pigtail	\$12
38172	89-95 4 Wire O2 Sensor (black)	\$13	38150	86-94 Blower Motor Pigtail	\$10
38173	89-94 4 Wire O2 Sensor (gray)	\$13	38152	94-96 Blower Motor Pigtail	\$12
38174	88-92 Throttle Pos. Sensor	\$11	38154	80-85 Ign. Coil Pigtail	\$5
38175	96 Throttle Pos. Sensor	\$11	38156	86-96 Ign. Coil Pigtail	\$10
38176	86-94 5 Lead Turn Signal	\$9	38158	80-89 4 Way Ign. Cont. Module	\$15
38178	86-94 8 Lead Turn Signal	\$16	38160	80-89 3 Way Ign. Cont. Module	\$15

TEE SHIRTS & DECALS



Standard shirt, front



Standard shirt, back



Logo shirt, front



Logo shirt, back

JBG APPAREL

Be comfortable and look great in these Jeff's Bronco Graveyard T-Shirts. No project is truly "finished" without one of these

19950	Standard JBG T-Shirt (large)	\$13
19952	Standard JBG T-Shirt (Med)	\$13
19955	Standard JBG T-Shirt (X-large)	\$13
19958	Standard JBG T-Shirt (XX-large)	\$14
19960	JBG Logo T-Shirt (Small)	\$10
19962	JBG Logo T-Shirt (Med)	\$10
19964	JBG Logo T-Shirt (Large)	\$10
19966	JBG Logo T-Shirt (X-Large)	\$10
19968	JBG Logo T-Shirt (XX-Large)	\$12

JBG HAT

JBG logo hat features: fabric strap with 2 piece velcro (one size fits most) and constructed with 6oz. weight fabric.

19940	JBG Hat, Black	\$12
19941	JBG Hat, Stone/Black	\$10



"BRONCOGRAVEYARD.COM" WINDSHIELD DECAL

39590W	Broncograveyard.com (white)	\$12
--------	-----------------------------	------

TORQUE SPECS

APPROXIMATE LUBRICANT REFILL CAPACITY

Transmission -- Ford 3.03	U.S.	Imperial	Litres
ESP-M2C83-C orEquivalent	3.5	3.0	1.6

TORQUE LIMITS

Item	Torque(ft-Lb)	Item	Torque(ft-Lb)
Input Shaft Gear Bearing Retainer toTransmission Case	30-36	Gear Shift Lever toCam & Shaft Assembly Lock Nuts	18-23
Transmission toFlywheel Housing	42-50	U-Joint FlangetoOutput Shaft	60-80
Transmission Cover to Transmission Extension	20-25	Filler Plug	10-20
Speedometer Cable Retainer to Transmission Extension	3-4.5	Shifter ForkSetScrew	10-18
Transmission Extension to Transmission Case	42-50		
Flywheel Housing to Engine	40-50		

ADJUSTMENTS-BRONCO TRANSFER CASE

Front Drive Output Shaft - End Play	0.001-0.005 in.
Rear Drive Output Shaft - End Play	0.001-0.005 in.

APPROXIMATE LUBRICANT REFILL CAPACITY-PINTS

TransferCase -- New Process	U.S.	Imp.	Litre
ESP-MC83-Cor Equivalent	4.5	3.75	2.1

SPECIAL TOOLS - NEW PROCESS TRANSFER CASE

Tool No.	Description
Tool4625-AB	Bearing Retainer Seal Installer
J-23429	Dummy Shaft (Idler Gear)
OTC-630-15	Idler Gear Bearing Cup Installer
Manzel 77288	Shift Rail Seal Installer

BRONCO 4X4 TRANSFER CASE TORQUE LIMITS

Description	Ft-Lb
Transfer Caseto TransmissionExtension Bolts	20-30
Gear Transfer Case toTransmission Output Shaft Nut	130-150
Front Output Shaft RearCover Bolts	25-32
Front Output Shaft Bearing Retainer Bolts	25-32
Idler Shaft Bolt-3/8 Cap Screw	13-17

TORQUE LIMITS-NEW PROCESS TRANSFER CASE

Description	Ft-Lb
Bearing Retainer Bolts --Front Output Shaft -- Front	20-40
Bearing Retainer Bolts -- Rear Output Shaft	20-40
Bearing Retainer Bolts -- Input Shaft	15-25
BearingRetainer Bolts -- Front Output Shaft -- Rear	20-40
Drain and Filler Plugs	25-35
Extension Housing toCaseBolts	25-35
Idler Shaft CoverBolts	15-25
Idler Shaft Locknut	90-130
Poppet Ball Retainer	15-25
P.T.O. Cover Bolts	12-18
Yoke (Companion Flange) Locknut	90-130
Seal Retainer Bolts, Front Input	30-40

DANA 44 FRONT AXLE TORQUE LIMITS

Description	Ft-Lb	Description	Ft-Lb
PinionShaft Nut	175-225	Ball Joint Nut -- Top	110-140
Differential BearingCap Bolts	70-90	-- Bottom	100
Ring Gear AttachingBolts	45-65	Oil Filler Plug	40
Cover to Housing Bolts	30-40	U-Joint Bolts	8-15
SpindleNut to Wheel Hub -- Inner	50	BackingPlate and Spindle to Sterring Knuckle	50-60
--Outer	50-80	RetainingBolts	

Dana Axle Torque Limits --- (Ft-LB)

Description	Axle Model		Description	Axle Model	
	60, 61	70, 70B		60, 61	70-70B
Pinion Shaft Nut	250-270	250-270	Oil Filler Plug	20-30	20-30
Differential Bearing Cap Bolts	80-90	80-90	U-Joint Bolts	15-20	15-20
Ring Gear Attaching Bolts	110-125	110-115	Cover toHousing Bolts	30-40	30-40
Differential Case Bolts		55-75			

DANA 60 FRONT AXLE TORQUE LIMITS

Description	Ft-Lb.	Description	Ft-Lb.
PinionShaft Nut	200-220	Spindle Nut to Wheel Hub -- Inner	50-70
DifferentialBearing Cap Bolts	70-90	--Outer	50-70
RingGear AttachingBolts	45-65	Spindle to Spindle Arm Bolts	50-60
Cover toHousing Bolts	30-40	Oil Filler Plug	40
Ball Joint -- Upper	100	U-Joint Bolt	8-15
-- Lower	70-90		
Back Plate/Spindle/Knuckle	50-60		

FRONT SUSPENSION LIMITS

Description	Model	Ft-Lbs.
Front Spring to Axle U-Bolt	F-600 (4x4) F-250 (4x4)	120-205 120-155
Front Spring Assembly to Front Hanger Bracket	F-600 (4x4) F-250 (4x4)	75-105 150-204
Front Spring Shackle to Shackle Bracket and Spring Front Jounce Bumper to Frame	F-250 (4x4) F-600(4x4)	90-130 50-70
Radius Arm to Bracket	F-250(4x4) Bronco, F-150(4x4)	15-25 80-120
Spring Retainer to Upper Spring Seat	Bronco, F-150 (4x4)	Bolt 20-30 Locknut 18-24
Track Bar Pivot to Frame	Bronco, F-150 (4x4)	119-1661
Track Bar to Pivot to Axle	Bronco, F-150 (4x4)	155-205
Lower Spring Seat to Radius Arm	Bronco, F-150 (4x4)	45-55
Axle Cap to Radius Arm Assembly	Bronco, F-150 (4x4)	90-110
Front Shock Bracket to Frame	F-250 (4x4)	35-45
Front Shock to Shock Bracket -- Lower	Bronco, F-150 (4x4)	40-60
Front Shock Absorber Stud -- Upper	Bronco, F-150 (4x4) F-250 (4x4)	15-25
Front Shock to Lower Mounting Bracket	F-250 (4x4)	15-25
Track Bar to Frame	F-150 (4x4)	9/12-12 Nut =50-70 7/16-14 Nut =20-30
Front Shock to Bracket --Upper	Bronco, F-150 (4x4)	15-25
Retainer to Radius Arm Bracket	Bronco, F-150 (4x4)	80-120
U-Bolt Nuts -- Retainer to Axle Bracket	Bronco, F-150 (4x4)	35-45
Front Spring Bracket to Frame	F-600 (4x4)	75-105
Rear Spring Bracket Clamping Bolt	F-600 (4x4)	31-42

REAR SUSPENSION TORQUE LIMITS -- F-SERIES, E-SERIES, BRONCO

Description	Model	Ft-Lb
Rear Shock Upper Mounting	F-100-F-250, F-150 (4x4), F-250 (4x4) E-100-350, F-350 SC, F-350, Bronco	15-25
Rear Shock Lower Mounting	F-Series, E-Series, Bronco	40-60
Rear Spring to Axle U-Bolt	F-150-F-250 (4x4), E-100-E-150	(9/16-12 Nut) 85-115
	F-350	110-160
	E-250-E-350	150-200
	Bronco	45-60
Rear Spring to Front Hanger	F-100, F-150 (4x2)	(9/16-12 Nut) 75-105
	F-150 (4x4), F-250, F-350 E-100-E-350	150-200 (5/8-11 Nut) 110-160
Rear Spring to Rear Hanger	F-100-F-350 SC, Bronco, E-100-E-350, F-150-F-250 4X4	75-105

FRONT & REAR AXLE LUBE CAPACITIES

Single-Speed Axle			
Make and Model	Approximate Capacity		
	U.S. Measure (Pts.)	Imperial Measure (Pts.)	Litres
Ford, All	6.5	5.4	3
Dana 44-9F Front	3.5	3-1/4	1.8
Dana 44-9F Front	4.0	3-1/4	1.8
Dana 44-6CF HD Front	4.0	3-1/4	1.8
Dana 60-7F Front	8.2	6.8	3.8
Dana 60-4x2	7.0	5.8	3.3
Dana 60-4x4	6.0	5	2.8
Dana 61-1	6.0	5	2.8
Dana 61-2 4x2	5.5	4.6	2.6
Dana 70	7.0	5.8	3.3
Dana 70	6.5	5.4	3

TORQUE SPECS DANA 44 FRONT IS

Description	N.m	(ft-lbs)
Bottom Ball Joint Nut	122-149	90-110
Top Ball Joint Nut	135 (Minimum)	100 (Minimum)
End Yoke Nut	271-298	200-220
Bearing Cap Bolts	108-122	80-90
Differential Retaining Bolts	41-54	30-40
Ring Gear Bolts	61-81	45-60

DANA AXLE ADJUSTMENTS

Description	Specification
Drive Pinion Preload	2.25-2.43 N.m (20-40 in-lbs)
Ring Gear Backlash	0.13-0.23mm (0.005-0.009 inch) No more than 0.08mm (0.003 inch) variation in any three places

REAR AXLE ADJUSTMENTS

Description	MM	Inch
Backlash Between Ring Gear and Pinion	0.203-0.304	0.008-0.012
Maximum Backlash Variation between Teeth	0.076	0.004
Maximum Runout of Backface of Ring Gear	0.076	0.003
Differential Side Gear Thrust Washer Thickness	0.762-0.812	0.030-0.032
Differential Pinion Gear Thrust Washer Thickness	0.762-0.838	0.030-0.033
Nominal Locating Shim (Continued) Removeable Carrier	0.381	0.015
Shims Available (Steps of 0.001) Removeable Carrier	0.254-0.736	0.010-0.029
Differential Bearing Preload New Bearings	0.203-0.304	0.008-0.012
Old Bearings	0.127-0.203	0.005-0.008

Ted Nugent's Gonzo reloaded.

Jeff's Bronco Graveyard is currently working in conjunction with Ted Nugent on his 1974 Bronco rebuild. Ted would like his Bronco Beast to be absolutely reliable and functional as a basic plow/work/hunting/farm-ranch truck. It is abused daily and finally needs an overhaul. Ted demands that all parts and accessories should be geared towards Heavy Duty Performance! Below are a couple pics of the finished product. See more at www.broncograveyard.com.



“My life is Bronco’ing that All American road less traveled, and all my off-road beasts are perfected by my Bronco Blood Brothers at Jeff’s Bronco Graveyard. Quality control, heart & soul dedication and maximum Spirit of the Wild touch!”

Ted Nugent

JBG appearance on Overhaulin’

As many of you already know, JBG was recently involved in a project with the TLC television show Overhaulin’. JBG supplied 3 huge crates full of Bronco parts and 2 JBG Bronco experts to help Chip Foose & the gang completely rebuild this 1968 Bronco in 7 days. To see more pictures of this awesome ground up restoration visit us at www.broncograveyard.com.



“Thanks to the Bronco Graveyard’s unbelievable knowledge of Bronco history, personable service and parts supply - as well as their invaluable work with Chip Foose and the Overhaulin’ gang - I now have the Bronco of my dreams.”

Michael Miles, owner of the 68 Overhaulin project Bronco

JEFF'S BRONCO GRAVEYARD

Annual

BRONCORAMA BRONCO & TRUCK SHOW

When:

First Saturday in May

9:00 AM - 3:00 PM

Where:

Jeff's Bronco Graveyard

7843 Lochlin Dr.

Brighton, MI 48116

Take advantage of "Broncorama only" prices and discounts.

Free swap meet

Concessions available

No registration required

Free raffle

JBG scratch & dent specials

Buy/Sell your Truck

Any questions? Contact Pat:

248-437-5060

Pat@Broncograveyard.com



DIFF WIZARD™

The World's
MOST POWERFUL
Differential Parts
Finder

Identify the exact part you need by
Year, Make, and Model of the vehicle!

Vehicle Info

YEAR:

MAKE:

MODEL:

DRIVE TYPE:

- ★ 24 Different vehicle makes
- ★ Hundreds of vehicle models
- ★ From 1948 to present day
- ★ Over 5,500 part numbers
- ★ 89 Product categories
- ★ 33 Product manufacturers
- ★ Over 130 differential types



Quickly and accurately
find the exact part for
your diff



Find helpful Wizard
hints to guide you



Help topic pop-ups to
ease the process

Experience the power today at...



Save time and money today.
Easily find and purchase the
right parts for your application.



Jeff's Bronco Graveyard Inc.
7843 Lochlin Dr.
Brighton, MI 48116

Presorted standard
US postage
PAID
Jeff's Bronco
Graveyard Inc.

*Check out these other great
catalogs from*

Jeff's Bronco Graveyard Inc.

- 1978-79 Bronco/1973-79 Pickup•
- 1966-77 Bronco•
- 1984-93 Bronco II/Ranger•

Download all of our catalogs at
WWW.BRONCOGRAVEYARD.COM

*Your ultimate source for Ford Bronco and
Truck parts & accessories!!!*

Jeff's Bronco Graveyard Inc.

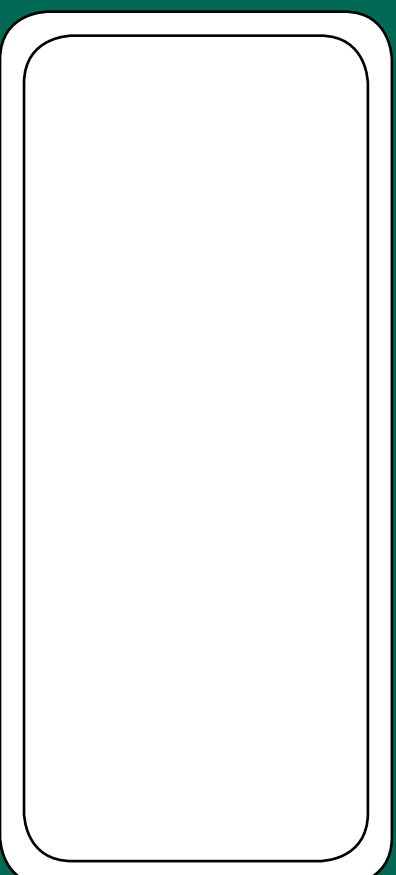

Buy or sell your Bronco or Pickup at
www.broncograveyard.com

Experience the largest Bronco site on the net. With over
300 pages of on-line content including features, net only
specials, and our HUGE on-line catalog.

Phone:

(248) 437-5060

(248) 486-1760

Fax:

(248) 437-9354