

# 1988 BRONCO/ F150-F350/ F-SUPER DUTY

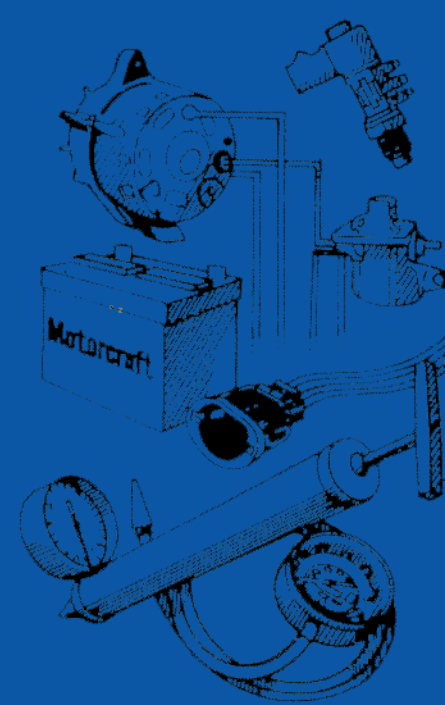

## Electrical & Vacuum Trouble- Shooting Manual

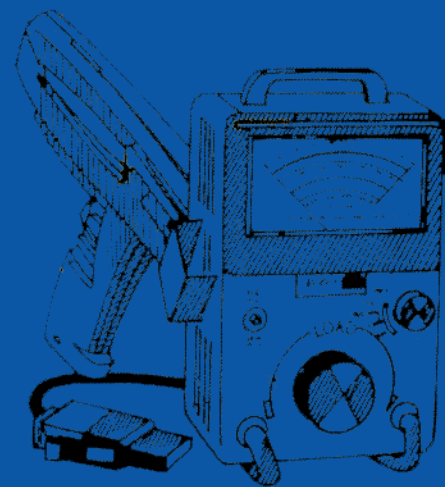

QUICK REFERENCE INDEX. To use, move either the hand or selection tool directly over the section you desire to reference. Simply click once with the mouse button and the manual will automatically jump to that section.



**DAVE GRAHAM**

**Auto Literature, Inc.**

**©2010 All rights reserved  
Made in the USA**

# ELECTRICAL AND VACUUM TROUBLESHOOTING MANUAL

**FPS — 12129 - 88**

## ORDER INFORMATION

Information on how to order additional copies of this publication or other Ford publications, may be obtained by writing to Helm Incorporated at the address shown below. Other publications available include:

- Shop Manuals
- Service Specification Books
- Car/Truck Wiring Diagram Books
- Engine/Emissions Diagnosis Manuals

**Helm Incorporated  
P.O. Box 07150  
Detroit, Michigan 48207**

## TABLE OF CONTENTS

How to Use This Manual .....	1
How to Find the Electrical Problem .....	2,3
Symbols (Electrical) .....	4
(Vacuum) .....	110
How to Find the Vacuum Problem .....	112
Component Testing .....	
Introduction .....	123
Main Light Switch .....	123
Hazard Switch .....	125
Ignition Switch .....	124
Turn Signal Switch .....	125
Windshield Wiper/Washer Switch .....	126
Interval Wiper/Washer Switch .....	127
A/C-Heater Function Selector .....	128
A/C-Heater Blower Switch .....	129
Location Index .....	130

## INDEX

A/C-Heater .....	117
Anti-Lock Brakes .....	75
Brake Warning Indicator .....	69
Charge (Gasoline) .....	15
(Diesel) .....	20
Cigar Lighter .....	88
Coolant Temperature Gage .....	82
Diesel Glow Plug Control .....	30
Electric Fuel Pump Control .....	86
Electronic Engine Control .....	35
Electronic Shift—4 Wheel Drive .....	77
Four-Wheel Drive Indicator .....	78
Fuel Injector Cooling Fan—(4.9L Only) .....	46
Fuel Tank Selector/Gages (Diesel) .....	83
(Gasoline) .....	81
Fuse Panel (Diesel) .....	22
(Gasoline) .....	17

Gages (Diesel) .....	83
(Gasoline) .....	81
Grounds .....	5
Heater .....	116
Horn .....	88
Ignition .....	25
Instrument Illumination .....	67
Lamps On Warning .....	63
Lamps .....	
Backup .....	61
Body Marker .....	52
Cargo .....	61
Dome .....	63
Exterior .....	50
Hazard .....	57
Headlamps .....	48
Instrument Illumination .....	67
License .....	51
Map .....	63
Marker .....	51
Park .....	51
Radio Illumination .....	67
Stop .....	57
Tail (Rear Park) .....	50
Trailer .....	52
Turn .....	57
Main Light Switch .....	67
Power Distribution (Diesel) .....	20
(Gasoline) .....	15
Power Door Locks .....	103
Power Windows .....	96
Radio (Stereo) (Electronic) .....	106
Rear Window Defrost .....	99
Seatbelt Warning .....	69
Speed Control .....	113
Start (Diesel) .....	30
(Gasoline) .....	25

Tachometer .....	82
Tailgate Power Window .....	99
Trailer .....	103
Vacuum Distribution .....	111
Warning Indicators (Diesel) .....	72
(Gasoline) .....	69
Windshield Wiper/Washer .....	91
Windshield Wiper/Washer (Interval) .....	93

### IMPORTANT SAFETY NOTICE

*Appropriate service methods and proper repair procedures are essential for the safe, reliable operation of all motor vehicles, as well as the personal safety of the individual doing the work. This Manual provides general directions for accomplishing service and repair work with tested, effective techniques. Following them will help assure reliability.*

*There are numerous variations in procedures, techniques, tools, and parts for servicing vehicles, as well as in the skill of the individual doing the work. This Manual cannot possibly anticipate all such variations and provide advice or cautions as to each. Accordingly, anyone who departs from the instructions provided in this Manual must first establish that he compromises neither his personal safety nor the vehicle integrity by his choice of methods, tools or parts.*

This manual contains the following diagnostic information:

- Electrical and Vacuum Schematics
- Component Location Indexes and Views
- Troubleshooting Hints
- Descriptions of Circuit Operation
- Component Testing

The vehicle's entire electrical system is broken down into individual systems. There are also sections for the vehicle's ground and power distribution circuitry. Each system section begins with a wiring schematic. The **Schematics** should always be your starting point in using this manual. These schematics show the paths of electrical current during proper circuit operation. The source of voltage (circuit breaker or fuse) is shown at the top of the page. All wire, connectors, splices, switches, and motors are shown in the flow of current to ground at the bottom of the page. Connector end views of switches and other components are shown to help with bench testing. Each circuit component is named (underlined titles). Wire and connector colors are listed (standard Ford color abbreviations are used). These abbreviations are:

## COLOR ABBREVIATIONS

BL	Blue	N	Natural
BK	Black	O	Orange
BR	Brown	PK	Pink
DB	Dark Blue	R	Red
DG	Dark Green	P	Purple
GR	Green	T	Tan
GY	Gray	W	White
LB	Light Blue	Y	Yellow
LG	Light Green		

Where two colors are shown for a wire, the first color is the basic color of the wire. The second color is the stripe marking.

The **Component Location** section of each system helps you locate the circuit's components in the vehicle. A brief statement of the location is given as well as a reference to an illustrative figure in the manual. There is also a full listing of connector, ground, and splice locations in the **Location Index** in the back of the manual.

## OTHER ABBREVIATIONS

**T/O (Tape Out)** The point at which a harness branches to feed a component.

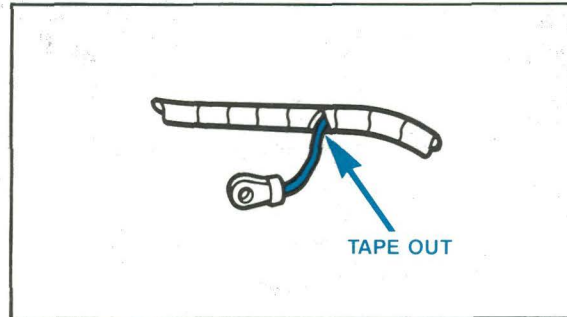

The **Troubleshooting Hints** offer shortcuts or tests that help you determine the cause of an electrical problem. They are not intended to be a rigid procedure for solving an electrical situation. Rather, Troubleshooting Hints represent a common-sense approach that is based on an understanding of the circuit.

A description of **How the Circuit Works** is written to help you understand the operation of the circuit as a whole. Emphasis is placed on how the components and circuitry interact in a properly working system.

A **Component Testing** section provides procedures to determine whether a component is good or bad.

**Notes, Cautions, and Warnings** appear in boxes on text pages and contain important vehicle and mechanic **safety** information.

Notes give added information to help complete a particular procedure. Cautions are included to prevent making an error that could damage the vehicle. Warnings highlight areas where carelessness can cause personal injury. The following list contains some general **Warnings** that should be followed when working on a vehicle.

- Always wear safety glasses for eye protection.
- Use safety stands whenever a procedure requires being under a vehicle.
- Be sure that the **Ignition Switch** is always in the OFF position, unless otherwise required by the procedure.
- Set the parking brake when working on any vehicle. An automatic transmission should be in PARK. A manual transmission should be in NEUTRAL.
- Operate the engine only in a well-ventilated area to avoid the danger of carbon monoxide.
- Keep away from moving parts when the engine is running, especially the fan and belts.
- To prevent serious burns, avoid contact with hot metal parts such as the radiator, exhaust manifold, tail pipe, catalytic converter, and muffler.
- Do not allow flame or sparks near the battery. Gases are always present in and around the battery cell. An explosion could occur.
- Do not smoke.
- To avoid injury, always remove rings, watches, loose hanging jewelry, and loose clothing.

## 2 HOW TO FIND THE ELECTRICAL PROBLEM

### TROUBLESHOOTING STEPS

These six steps present an orderly method of troubleshooting:

#### Step 1. Verify the problem.

- Operate the complete system and see all symptoms for yourself in order to:
  - check the accuracy and completeness of the customer's complaint.
  - learn more that might give a clue to the nature and location of the problem.

#### Step 2. Narrow the problem.

- Using this manual, narrow down the possible causes and locations of the problem in order to more quickly find the exact cause.
- Read the description of *How the Circuit Works* and study the wiring diagram. You should then know enough about the circuit operation to figure out where to check for this trouble.

#### Step 3. Test the cause.

- Use electrical test procedures to find the specific cause of the symptoms.
- *Troubleshooting Hints* will give some helpful ideas.
- The *Component Location* charts and the pictures will help you find components, grounds, and connectors.

#### Step 4. Verify the cause.

- Confirm the fact that you have found the correct cause through operating the parts of the circuit you think are good.

#### Step 5. Make the repair.

- Repair or replace the faulty component.

#### Step 6. Verify the repair.

- Operate the system as in Step 1 and check that your repair has removed all symptoms, and also has not caused any new symptoms.

Some engine circuits may need special test equipment and special procedures. See the

*Shop Manual* and other service books for details. You will find the circuits in this manual to be helpful with these special tests.

### TROUBLESHOOTING TOOLS

#### JUMPER WIRE

This is a test lead used to connect two points of a circuit. A **Jumper Wire** can complete a circuit by bypassing an open.

**Uses:** Bypassing Switches or Open Circuits

#### WARNING

*Never use a jumper wire across loads (motors, etc.) connected between hot and ground. This direct battery short may cause injury or fire.*

#### VOLTMETER

A DC **Voltmeter** measures circuit voltage. Connect negative (- or black) lead to ground, and positive (+ or red) lead to voltage measuring point.

#### OHMMETER

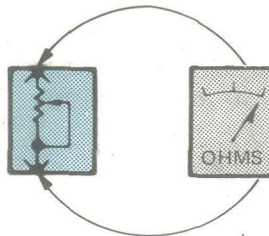

Figure 1— Resistance Check

An **Ohmmeter** shows the resistance between two connected points (Figure 1).

#### TEST LIGHT

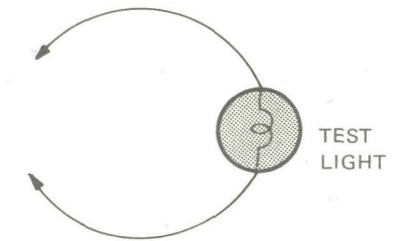

Figure 2—Test Light

A **Test Light** is a 12-volt bulb with two test leads (Figure 2).

**Uses:** Voltage Check. Short Check

#### SELF-POWERED TEST LIGHT

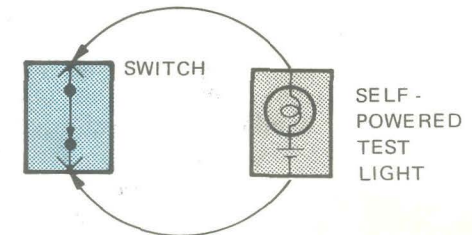

Figure 3—Continuity Check

The **Self-Powered Test Light** is a bulb, battery and set of test leads wired in series (Figure 3). When connected to two points of a continuous circuit, the bulb glows.

**Uses:** Continuity Check. Ground Check

#### CAUTION

*When using a self-powered test light or ohmmeter, be sure power is off in circuit during testing. Hot circuits can cause equipment damage and false readings.*

## TROUBLESHOOTING CHECKS

### SWITCH CIRCUIT CHECK

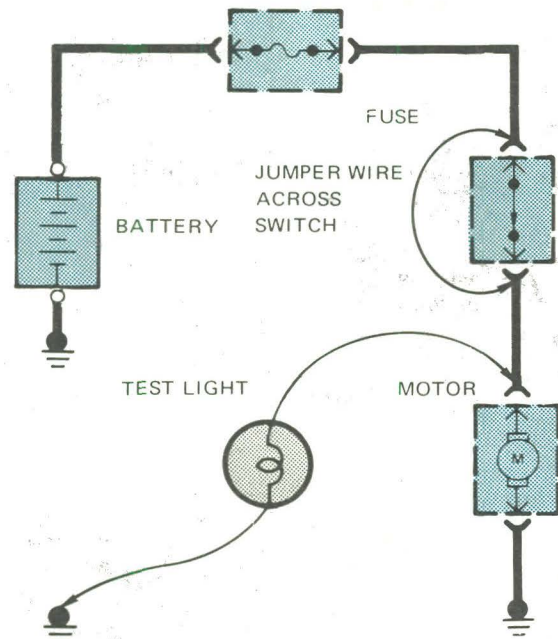

Figure 4—Switch Circuit Check and Voltage Check

In a bad circuit with a switch in series with the load, jumper the terminals of the switch to power the load. If jumping the terminals powers the circuit, the switch is bad (Figure 4).

### CONTINUITY CHECK (Locating open circuits)

With power off, connect one lead of **Self-Powered Test Light** or **Ohmmeter** to each end of circuit (Figure 3). Light will glow if circuit is closed. Switches and fuses can be checked in the same way.

### VOLTAGE CHECK

Connect one lead of **Test Light** to a known good ground or the negative, (-) battery terminal. Test for voltage by touching the other lead to the test point. Bulb goes on when the test point has voltage (Figure 4).

### SHORT CHECK (short to ground)

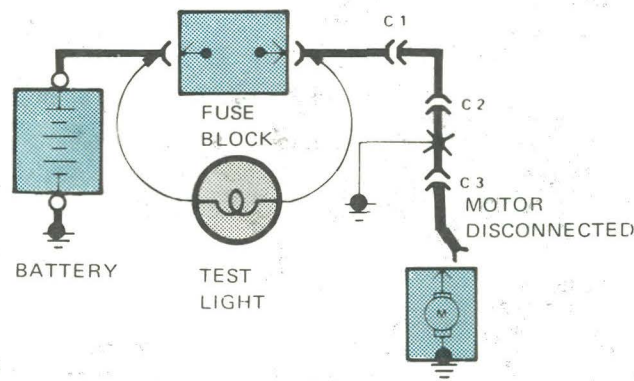

Figure 5— Short Check

A fuse that repeatedly blows is usually caused by a short to ground. It's important to be able to locate such a short quickly (Figure 5).

- 1) Turn off everything powered through the fuse.
- 2) Disconnect other loads powered through the fuse:
  - Motors: disconnect motor connector.
  - Lights: remove bulbs.
- 3) Turn **Ignition Switch** to RUN (if necessary) to power fuse.
- 4) Connect one **Test Light** lead to hot end of blown fuse. Connect other lead to ground. Bulb should glow showing power to fuse. *(This step is just a check to be sure you have power to the circuit.)*
- 5) Disconnect the **Test Light** lead from ground and reconnect it to the load side of the fuse.
  - If the **Test Light** is off, the short is in the disconnected equipment.
  - If the **Test Light** goes on, the short is in the wiring. You must find the short by disconnecting the circuit connectors one at a time until the **Test Light** goes out. For example: with a ground at X, the bulb goes out when C1 or C2 is disconnected, but stays on after disconnecting C3. This

means the ground is between C2 and C3.

### "GOOD GROUND" CHECK

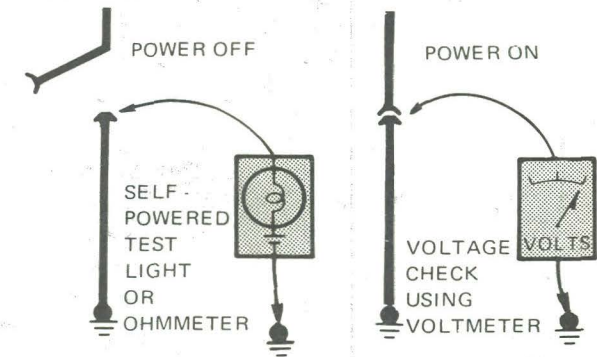

Figure 6 – Grounds Checks

Turn on power to circuit. Perform Voltage Check between suspected bad ground and frame. Any voltage means ground is bad.

Turn off power to circuit. Connect one lead of **Self-Powered Test Light** or **Ohmmeter** to wire in question, and the other to known ground. If bulb glows, circuit ground is OK (Figure 6).

## TROUBLESHOOTING HINTS

The circuit schematics in this manual are designed to make it easy to identify common points in circuits. This knowledge can help narrow the problem to a specific area. For example, if several circuits fail at the same time, check for a common power or ground connection. (See *Power Distribution* or *Grounds*). If part of a circuit fails, check the connections between the part that works and the part that doesn't work.

For example, if low beam headlights work but high beams and the indicator light don't work, then power and ground paths must be good. Since the dimmer switch is the component which switches this power to the high beam lights and indicator, it is most likely the cause of failure.

# 4 ELECTRICAL SYMBOLS

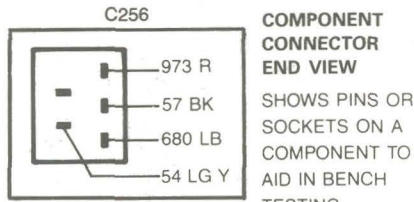

WIRE COLORS ARE LABELED FOR MATING HARNESS CONNECTOR

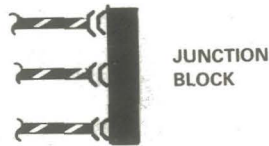
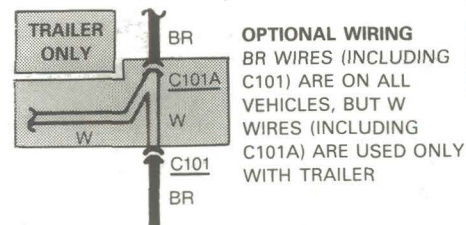
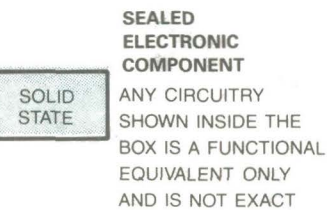
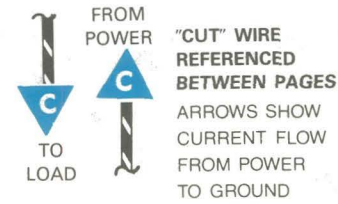
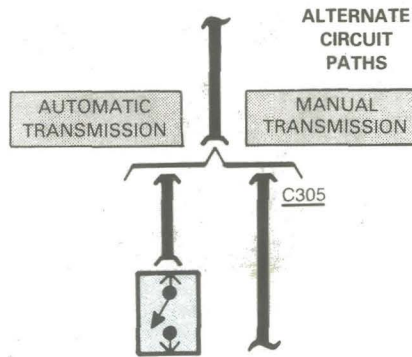
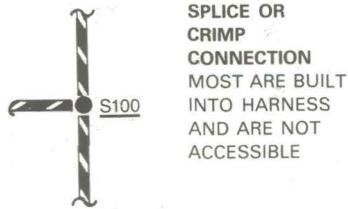
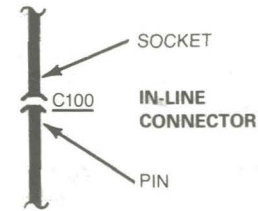
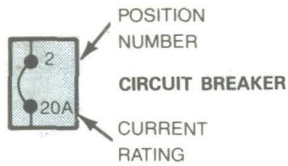
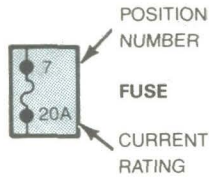
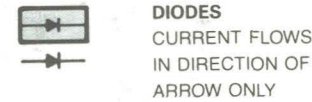
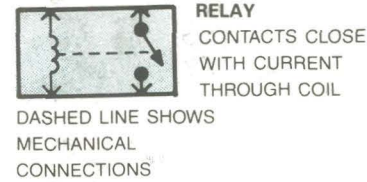

SEE GROUNDS PAGE 5-15

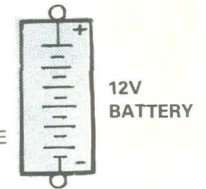
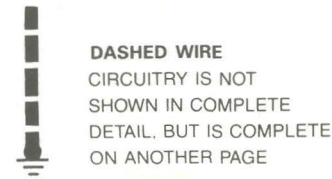

## INSTRUMENT PANEL GROUND

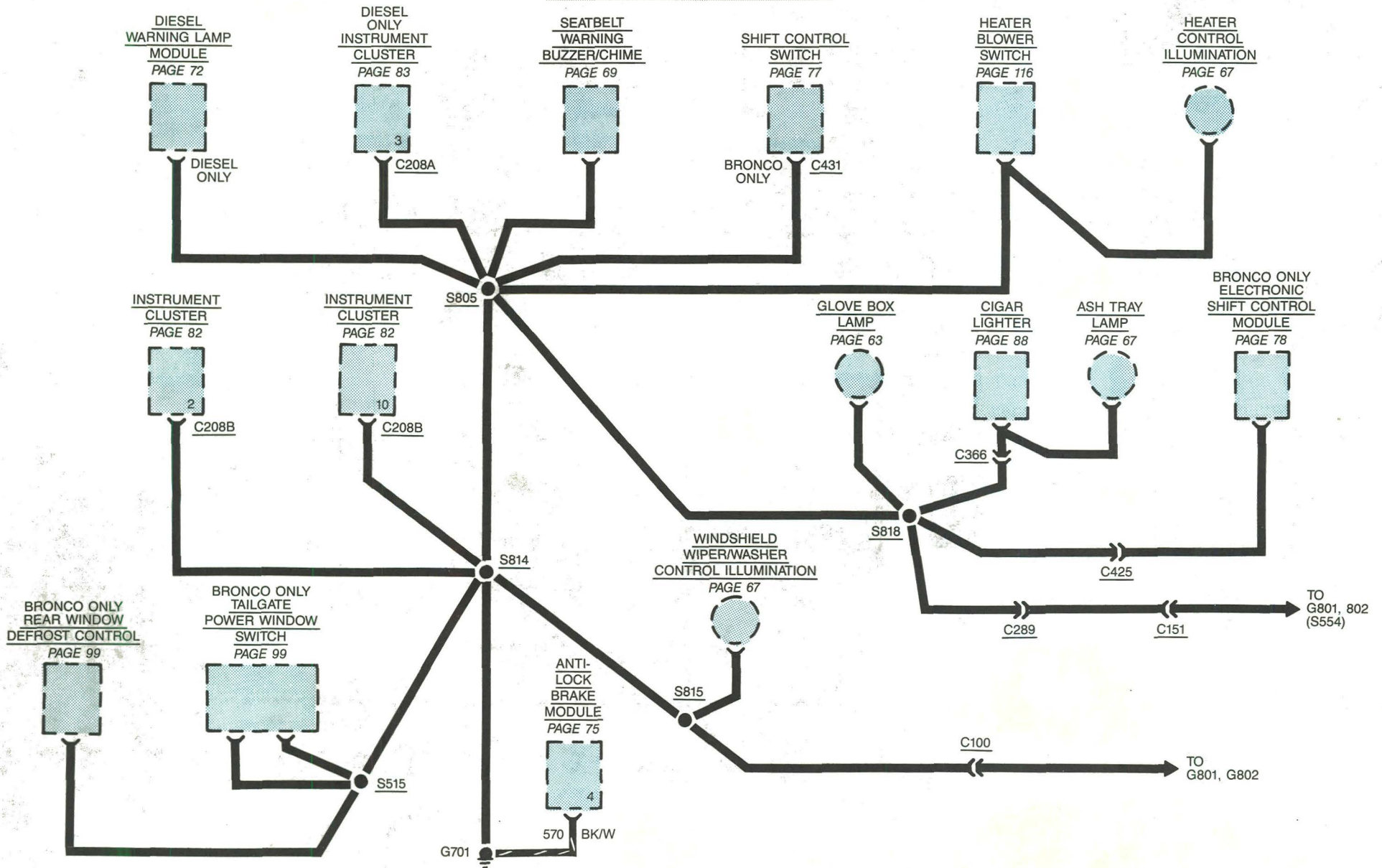

# 6 GROUNDS (G801, 802)

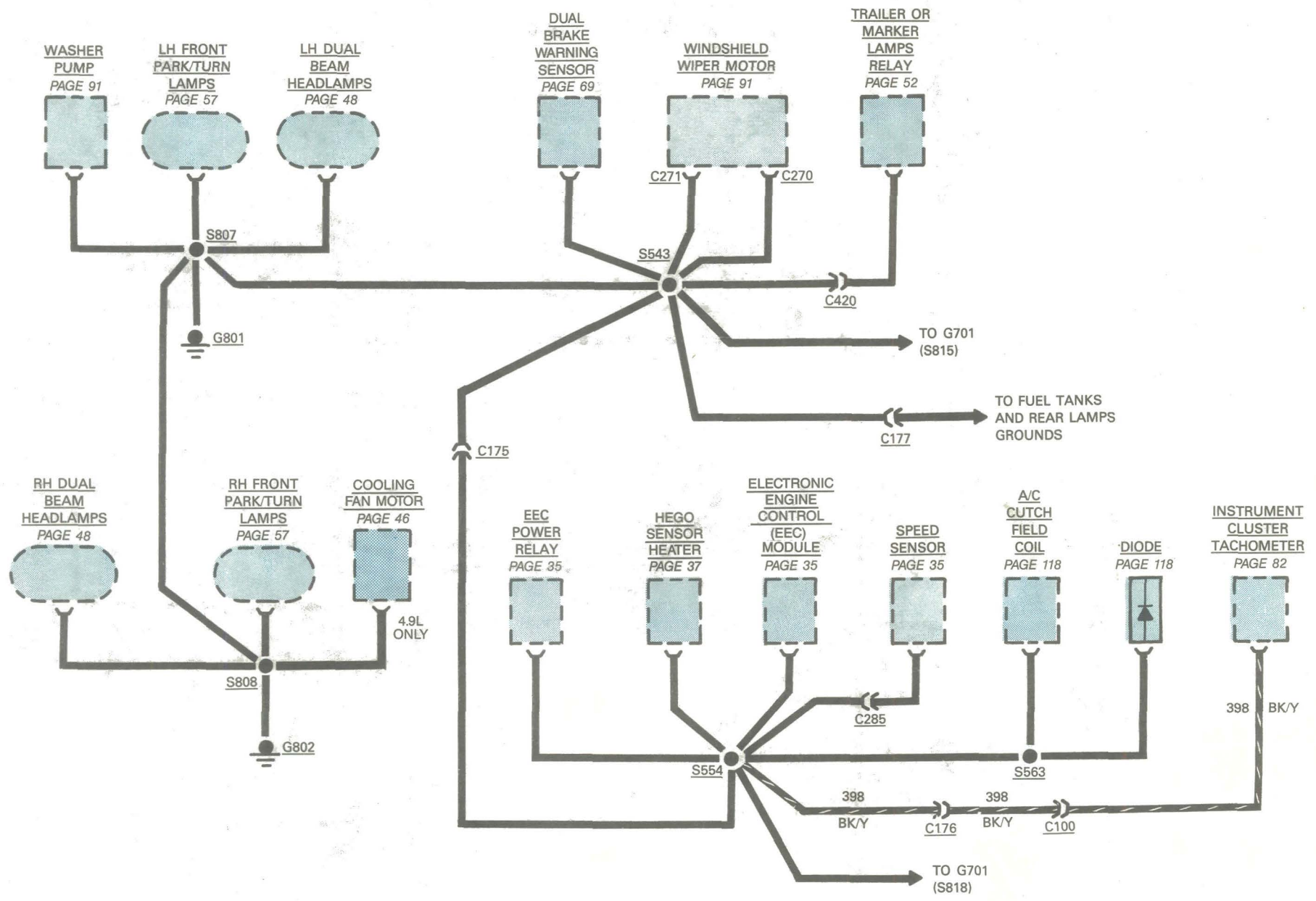

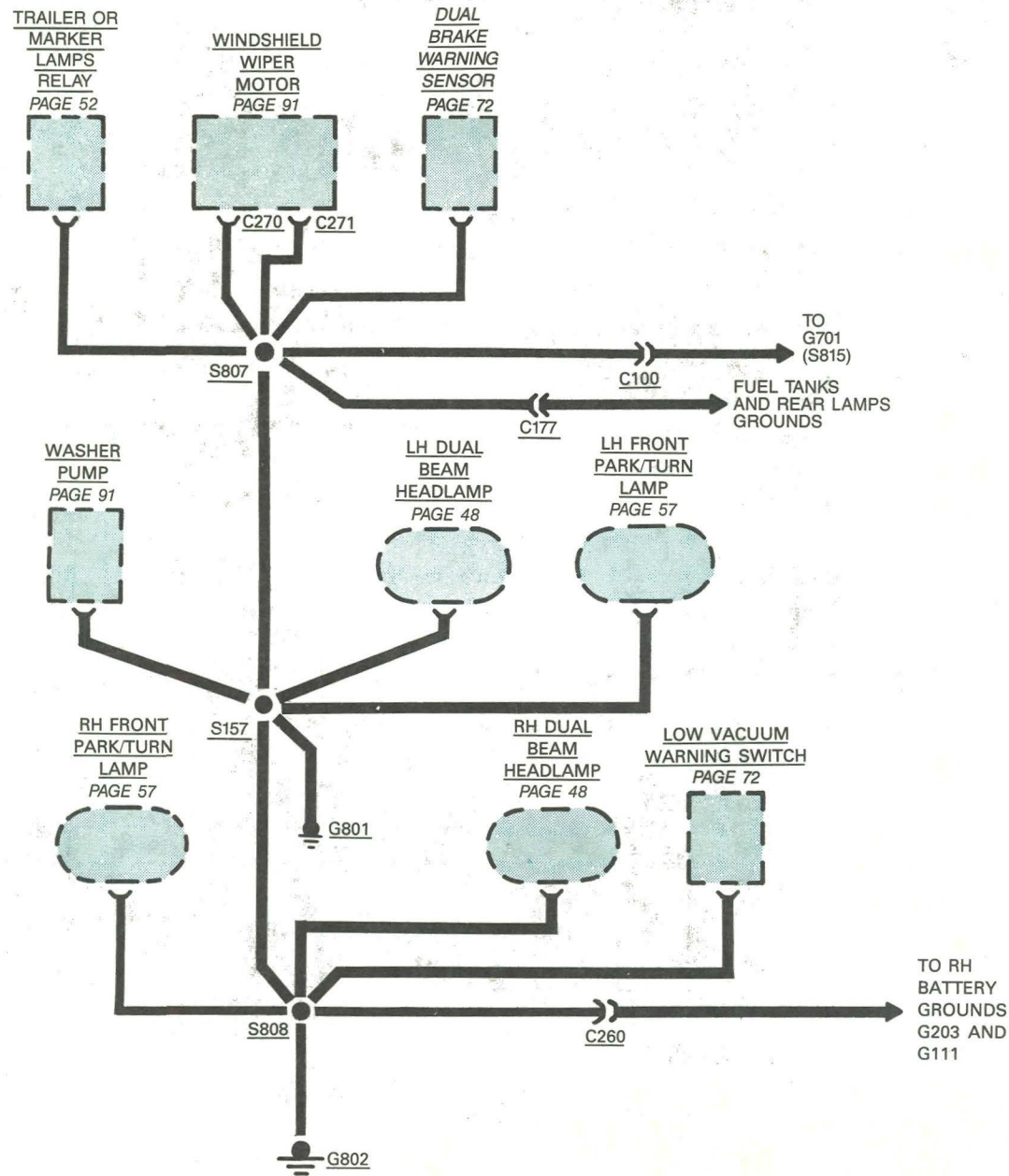

# 8 GROUNDS (FUEL TANKS AND REAR LAMPS)

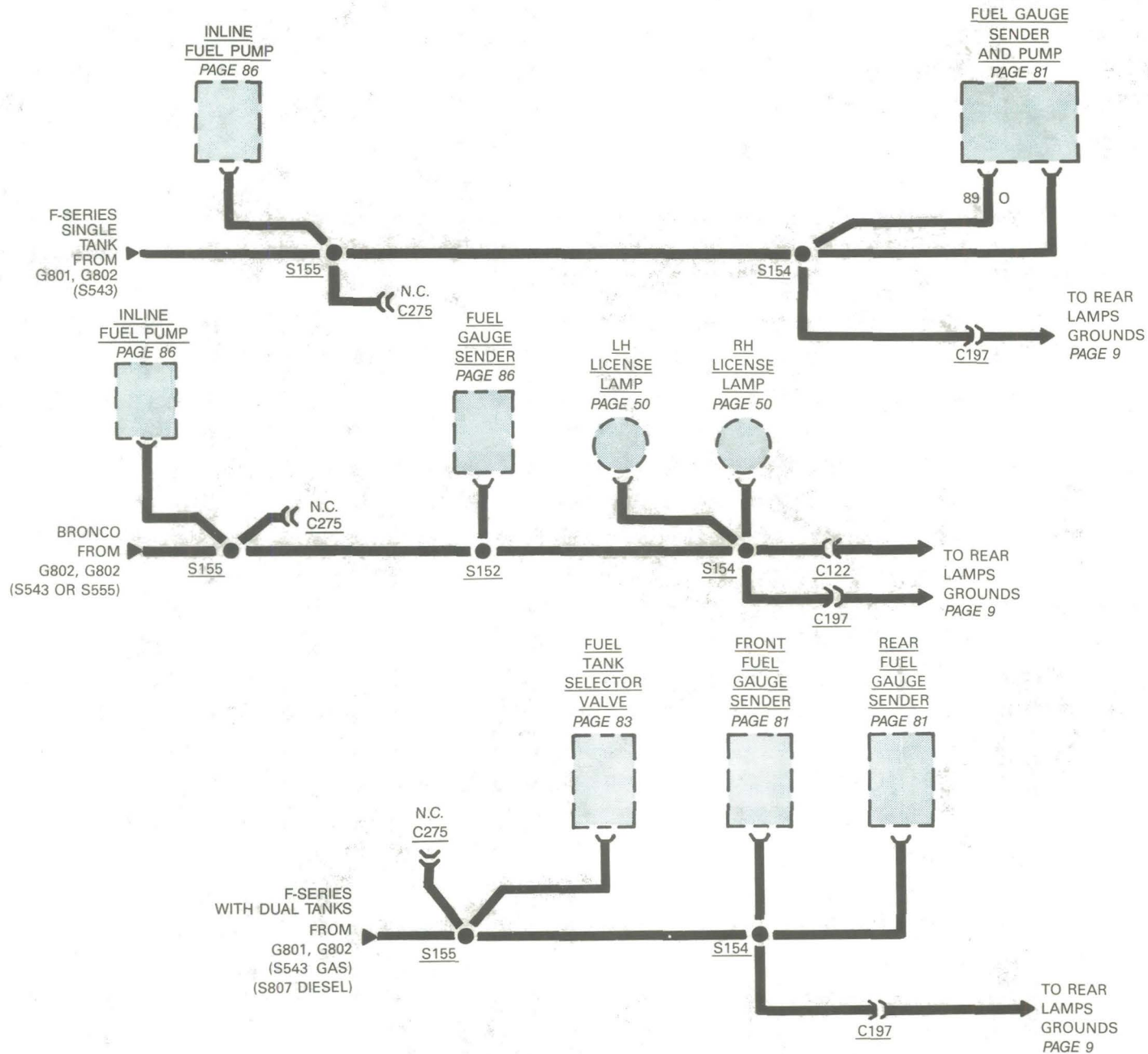

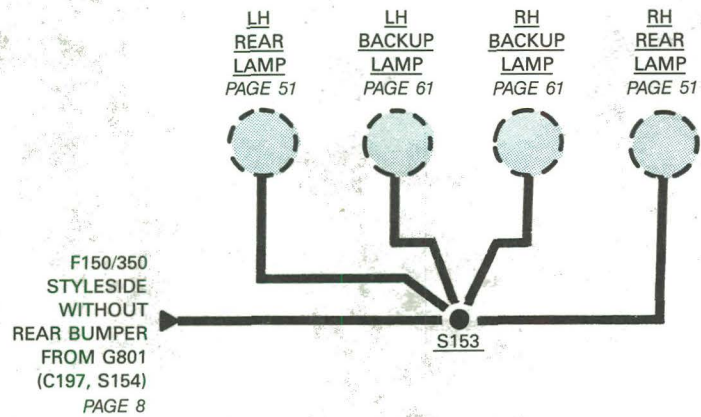
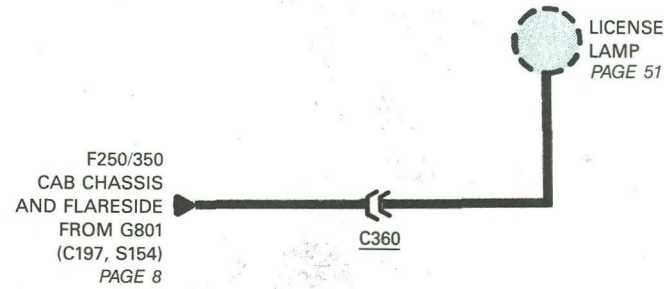
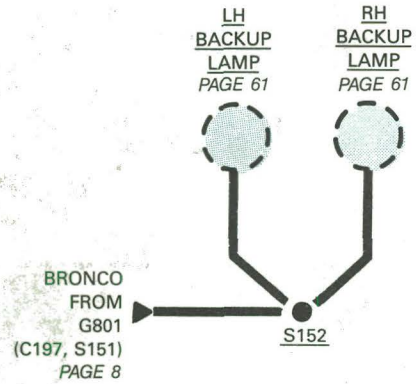
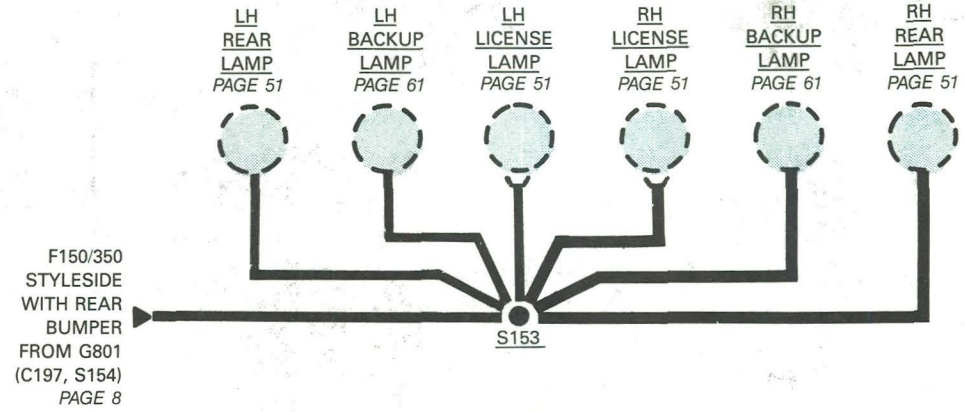
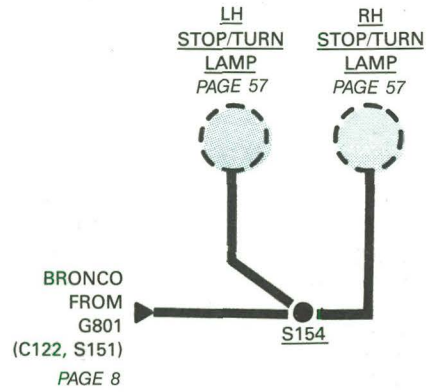

# 10 GROUNDS (G903, G909, G752)

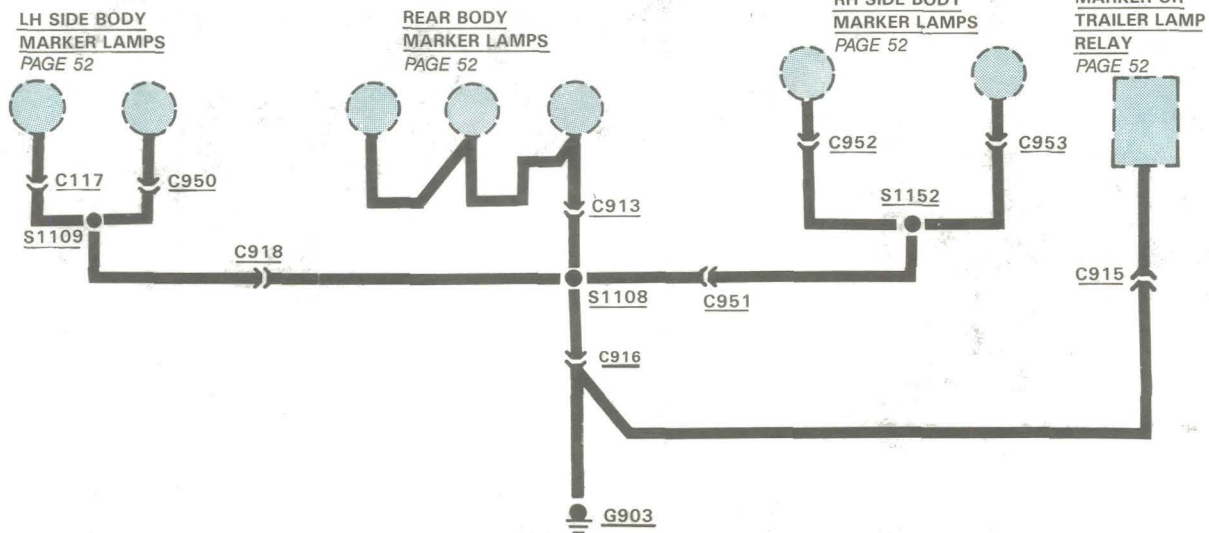
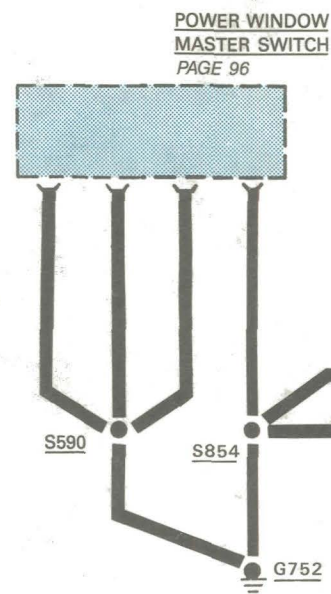
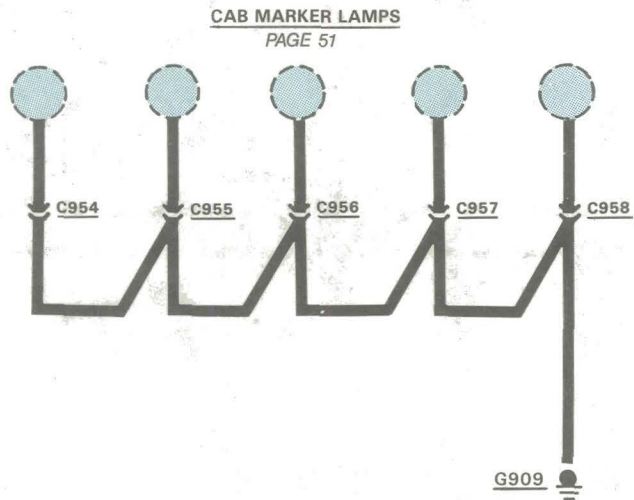

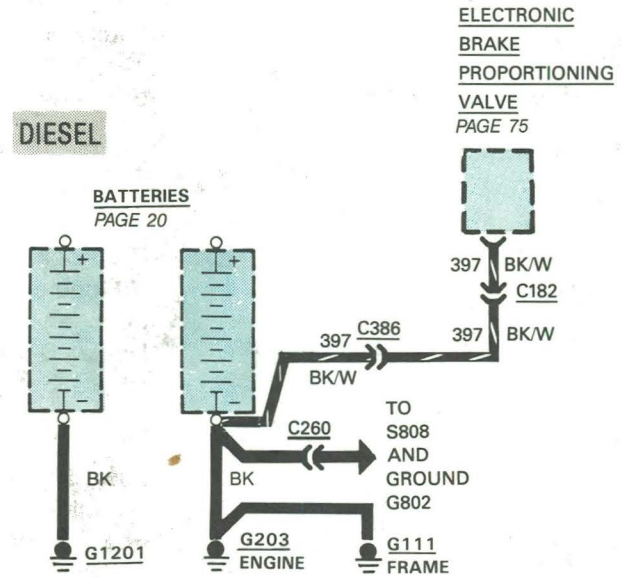
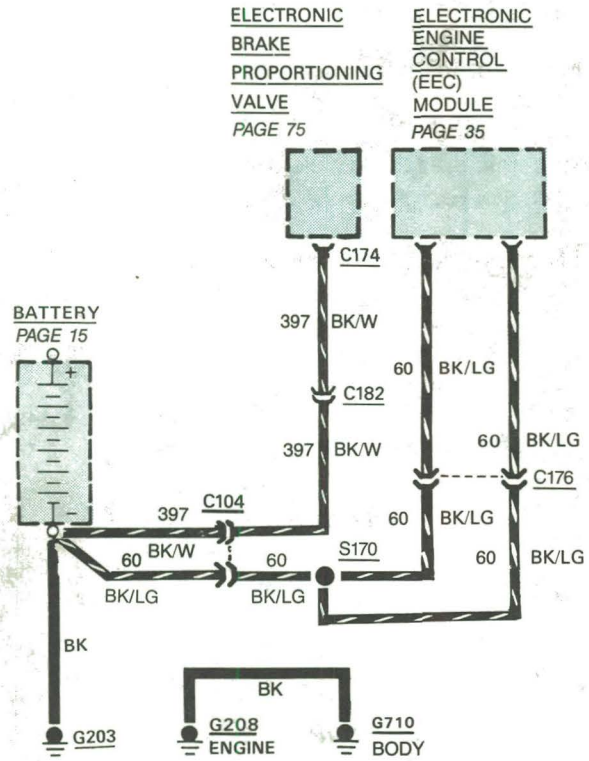

## HOW THE CIRCUIT WORKS

The ground circuits shown here are complete and connect several components together to screw terminal ground points. On other pages only parts of these circuits may be shown. Partial ground circuits are shown dashed on those pages.

All simple or component ground circuits are shown on the individual circuit pages and are complete on those pages.

All ground wires are **57 BK** unless otherwise noted.

## COMPONENT LOCATION

	Page- Figure
A/C Clutch Field Coil . . . . .	Part of compressor . . . . .
Anti-Lock Brake Module . . . . .	Behind I/P left of center . . . . .
Brake Sensor . . . . .	Part of master cylinder . . . . .
Cooling Fan Motor . . . . .	RH fender apron . . . . .
Diesel/Warning Lamp Module . . . . .	Behind LH side of I/P near fuse panel . . . . .
Electronic Engine Control (EEC) Module . . . . .	Behind LH kick panel . . . . .
EEC Power Relay . . . . .	Under plastic shield at the air cleaner support bracket . . . . .
Electronic Brake Proport- ioning Valve . . . . .	Inside of LH frame rail behind #1 cross- member . . . . .
Electronic Shift Control Module . . . . .	RH cowl panel . . . . .
Fuel Tank Selector Valve . . . . .	On LH side frame member behind cab . . . . . 85-1
Heater Blower Switch . . . . .	At center of I/P . . . . .
HEGO Sensor . . . . .	In communicator tube connecting both exhaust pipes . . . . . 29-3,122-2
Inline Fuel Pump . . . . .	Inboard side of LH frame rail . . . . .
Low Vacuum Warning Switch . . . . .	7.3L RH fender apron . . . . .
Power Window Master Switch . . . . .	In LH door . . . . .
Rear Defrost Control . . . . .	Under LH corner of I/P . . . . .
Seatbelt Warning Buzzer/Chime . . . . .	Attached to rear RH side of I/P . . . . . 101-2
Shift Control Switch . . . . .	On LH side of I/P . . . . .
Speed Sensor . . . . .	At transmission . . . . .
Tailgate Power Window Motor . . . . .	In center of tailgate . . . . . 102-3
Washer Pump . . . . .	In washer reservoir . . . . .
Windshield Wiper Motor . . . . .	Attached to center of dash panel . . . . .

Refer to the **Location Index** in the back of the manual for connector, ground, and splice descriptions and locations.

## REPLACEMENT OF FUSES/ CIRCUIT BREAKERS



**GOOD FUSE**



**BLOWN FUSE**

Fuses are mounted either in the **Fuse Panel** or in-line. They are identified by the numbered value in amperes, and by a color code. Some positions may have either a fuse with adapter or a circuit breaker. Be sure to replace a fuse or circuit breaker with the same kind of unit and with the same ampere rating. Remove fuses in order to check them.

## CIRCUIT BREAKER OPERATION

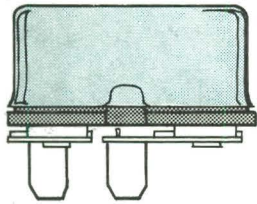

**EXTERNAL  
SIDE VIEW**

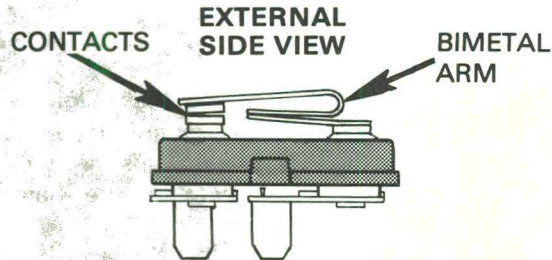

**INTERNAL  
SIDE VIEW**

**Cycling Fuse Block Type**

Some circuits are protected by circuit breakers. (Abbreviated "c.b." in fuse chart.) They can be **Fuse Panel** mounted or in-line. Like fuses, they are rated in amperes.

Each circuit breaker conducts current through an arm made of two types of metal bonded together (bimetal arm). If the arm starts to carry too much current, it heats up. As one metal expands faster than the other, the arm bends, opening the contacts. Current flow is broken. In the cycling type, the arm cools and straightens out. This closes the circuit again. This cycle repeats as long as the overcurrent exists, with power applied.

In the non-cycling type, there is also a coil wrapped around the bimetal arm. When an overcurrent exists and the contacts open, a small current passes through the coil. This current through the coil is not large enough to

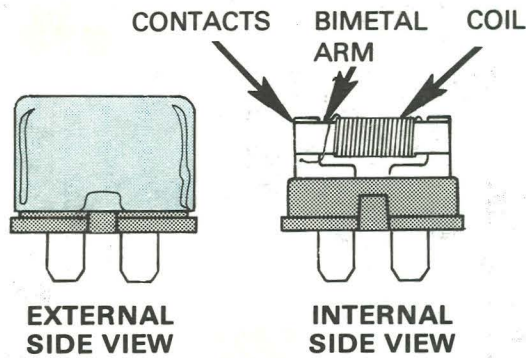

**Non-Cycling Fuse Block Type**



**Cycling In-Line Type**

## FUSE LINKS

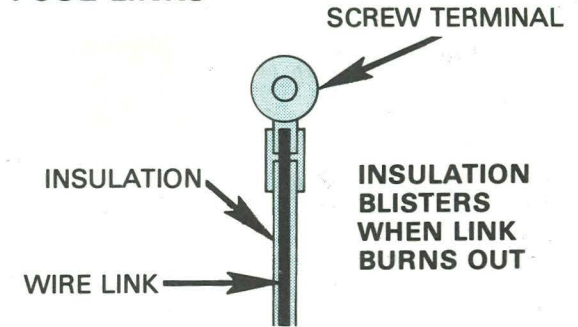

operate a load, but it does heat up both the coil and bimetal arm. This keeps the arm in the open position until power is removed.

The fuse link is a short length of wire smaller in gage than the wire in the protected circuit. The wire is covered with a thick non-flammable insulation. An overload causes the link to heat and the insulation to blister. If the overload remains, the link will melt, causing an open circuit.

When replacing, make tight crimp joints or hot solder joints for good connections.

## DIODES



Diodes are electrical devices that permit current to flow in one direction only. The current flows in the direction indicated by the arrow.

# 14 FUSE PANEL/CIRCUIT PROTECTION

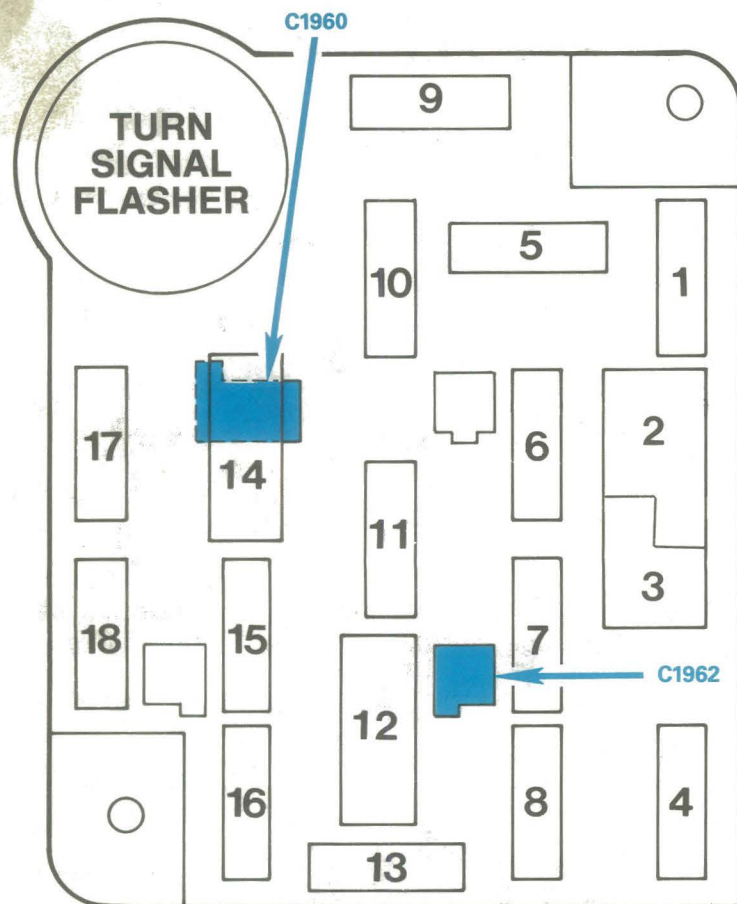

Fuse Position	Amps	Circuits Protection
1	15	Turn/Stop/Hazard Lamps; Speed Control
2	—	(Not used)
3	—	(Not used)
4	15	Exterior Lamps; Instrument Illumination
5	15	Turn Lamps; Backup Lamps; Rear Window Defrost
6	15	Speed Control; Electronic Shift-4 Wheel Drive
7	—	(Not Used)
8	15	Courtesy, Dome, Cargo Lamps; Warning Buzzer
9	30	Heater; A/C-Heater
10	5	Instrument Illumination; Clock Dimming
11	15	Radio; Main Light Switch; Clock Illumination
12	25	Tailgate Power Window; Power Mirrors
13	30 c.b.	Power Door Locks; Electronic Shift-4 Wheel Drive
14	—	(Not used)
15	25	Tailgate Power Window
16	30 c.b.	Power Windows
17	10	Auxiliary Fuel Tank Selector
18	30	Horn; Cigar Lighter; Speed Control; 4.9L EFI After Run Blower
19	20	Anti-lock Brakes
20	15	Seatbelt Buzzer; Warning Indicators; Diesel Glow Plug Control; Diesel Indicators; Tachometer

Figure 1 - Fuse Panel

Fuse Value Amps	Color Code
4	Pink
5	Tan
10	Red
15	Light Blue
20	Yellow
25	Natural
30	Light Green

### Power Distribution

The **Alternator** and **Battery** are connected together at the **Starter Relay** hot terminal. Other circuits originate at the **Starter Relay** hot terminal and are protected by fuse links. Low power circuits are also protected by fuses.

The **Ignition Switch** and **Main Light Switch** are powered at all times as are **Fuses 1, 4, 8, 12, and 16**. The other fuses are powered through the **Ignition Switch** or the **Main Light Switch**.

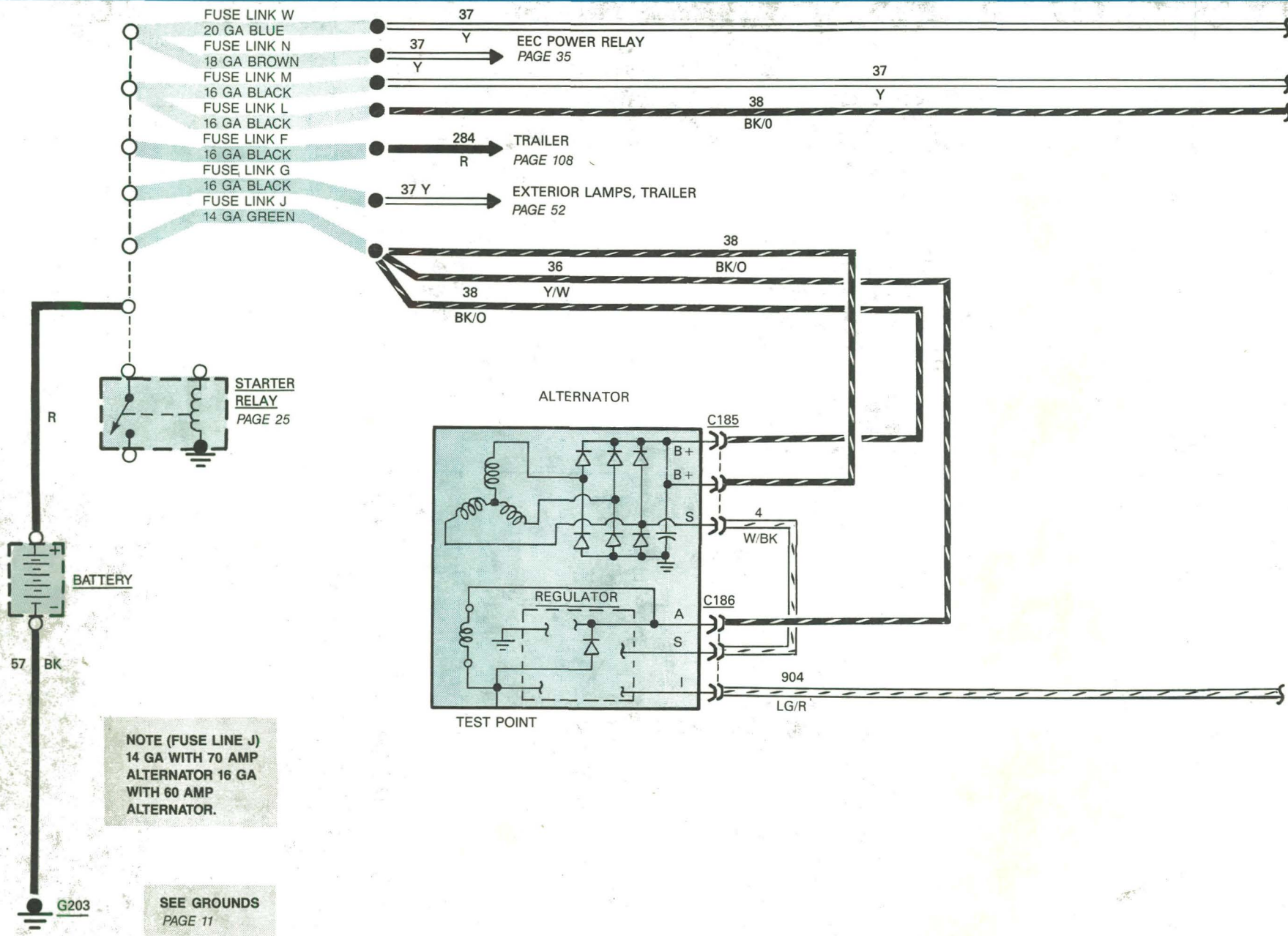



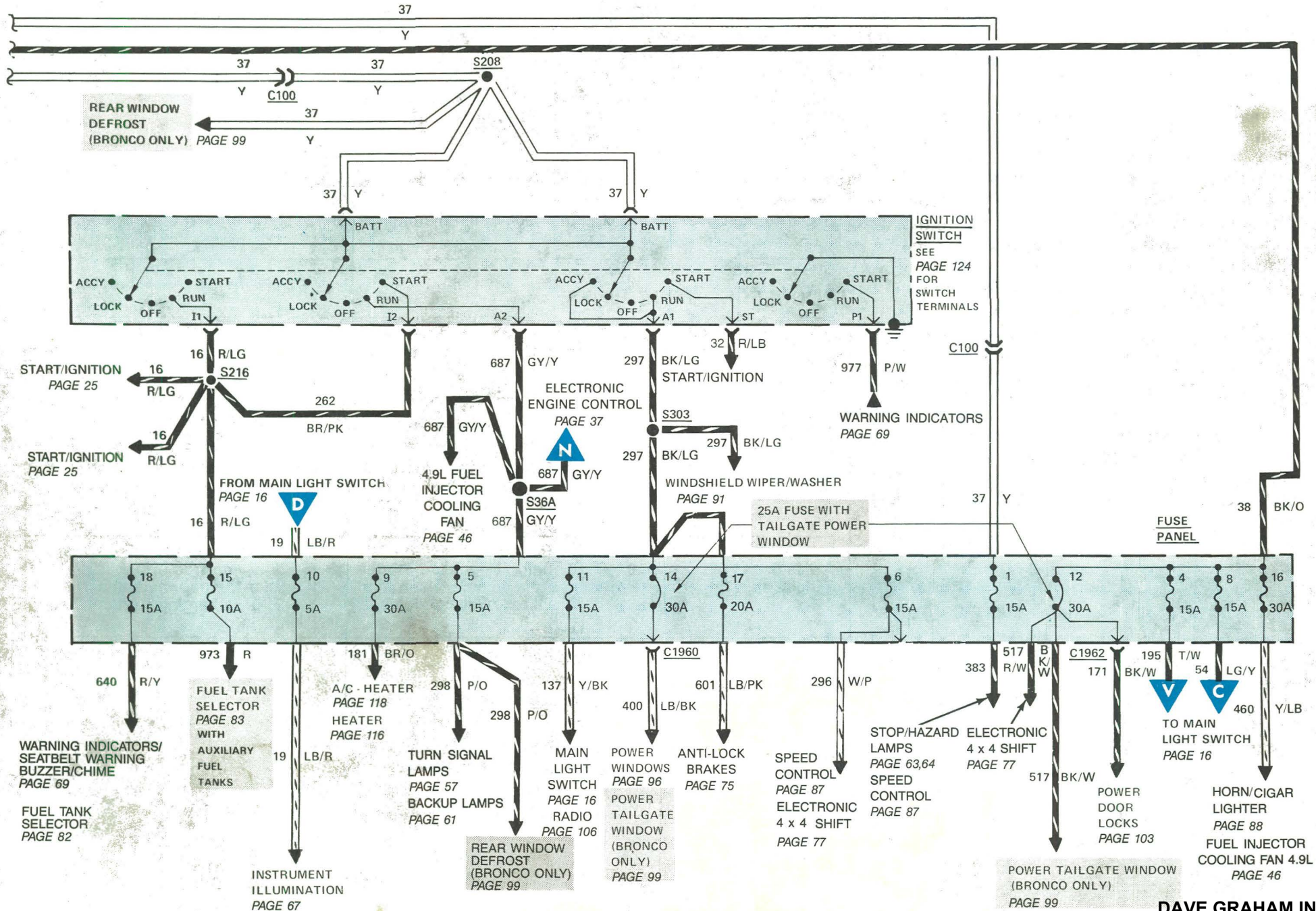

# 18 CHARGE/POWER DISTRIBUTION

## HOW THE CIRCUIT WORKS

The **Battery**, **Alternator** and **Voltage Regulator** make up the **Charging System**. With the **Ignition Switch** in RUN, **Battery** voltage is applied through the solid-state electronic control of the **Voltage Regulator**. The electronic control applies **Battery** voltage to the **Alternator** field.

With current in the field and the rotor turning, the **Alternator** stator produces a DC voltage at B+ terminals (to **Battery**). If the **Alternator** output voltage is greater than the **Battery** terminal voltage, current will flow from the **Alternator** to the **Battery**, as well as to the vehicle electrical load.

If the **Alternator** voltage is less than the **Battery** terminal voltage, current will flow from the **Battery** to supplement the alternator output in supplying the vehicle electrical load.

Refer to section 31-01 of the shop manual.

## COMPONENT LOCATION

Page-  
Figure

Fuse Links F, G, J, L, M, N, W .....	Near starter relay .....
Radio Noise Capacitor ...	Attached to voltage regulator .....
Starter Relay .....	On RH fender apron .....

Refer to the **Location Index** in the back of the manual for connector, ground, and splice descriptions and locations.

## TROUBLESHOOTING HINTS

CONDITION	POSSIBLE CAUSE	ACTION
<ul style="list-style-type: none"> <li>Improper Charging</li> </ul>	<ul style="list-style-type: none"> <li>Loose/worn alternator belt</li> <li>Defective/dead battery</li> <li>Fuse Link J open at starter relay</li> <li>Poor connection between battery terminals and cable clamps/damaged cables</li> </ul>	<ul style="list-style-type: none"> <li>Tighten/replace</li> <li>Replace battery</li> <li>Visually check for open in link, replace</li> <li>Clean, tighten and/or replace</li> </ul>
<ul style="list-style-type: none"> <li>Alternator Warning Indicator remains on after initial start up</li> </ul>	<ul style="list-style-type: none"> <li>Poor connection on Alternator, Regulator, Starter Relay, and/or Alternator Output Control Relay</li> </ul>	<ul style="list-style-type: none"> <li>Make sure connections are tight and free of debris and refer to shop manual section 31-01, Charging System Diagnosis</li> </ul>

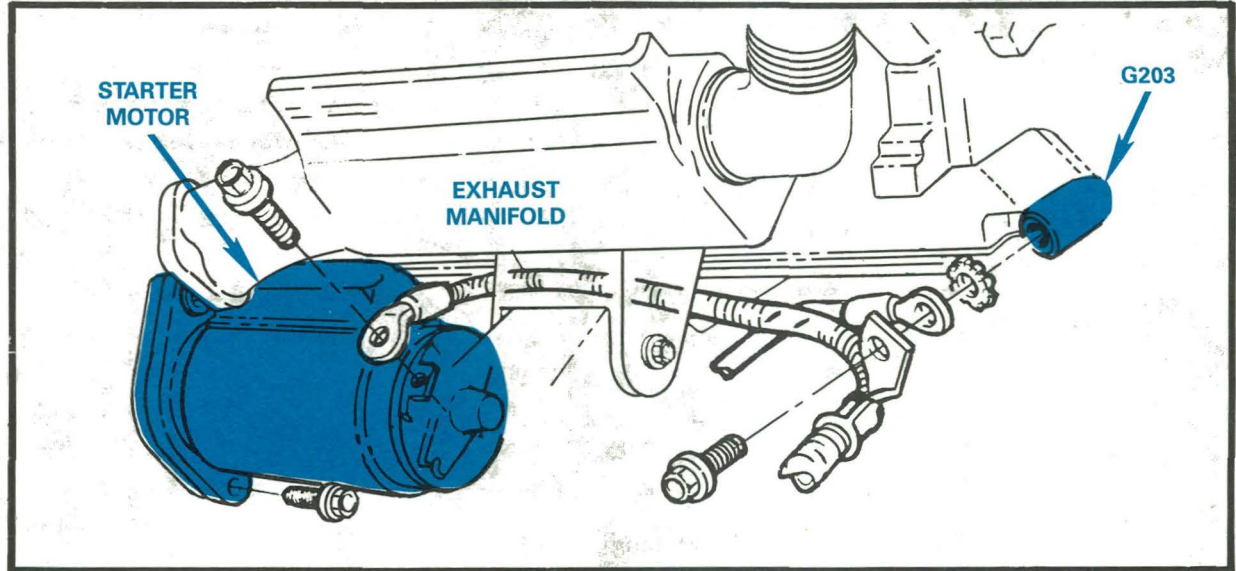

Figure 1 — Lower RH Side of Engine (5.0L, 5.8L, 7.5L, 8 Cyl.)

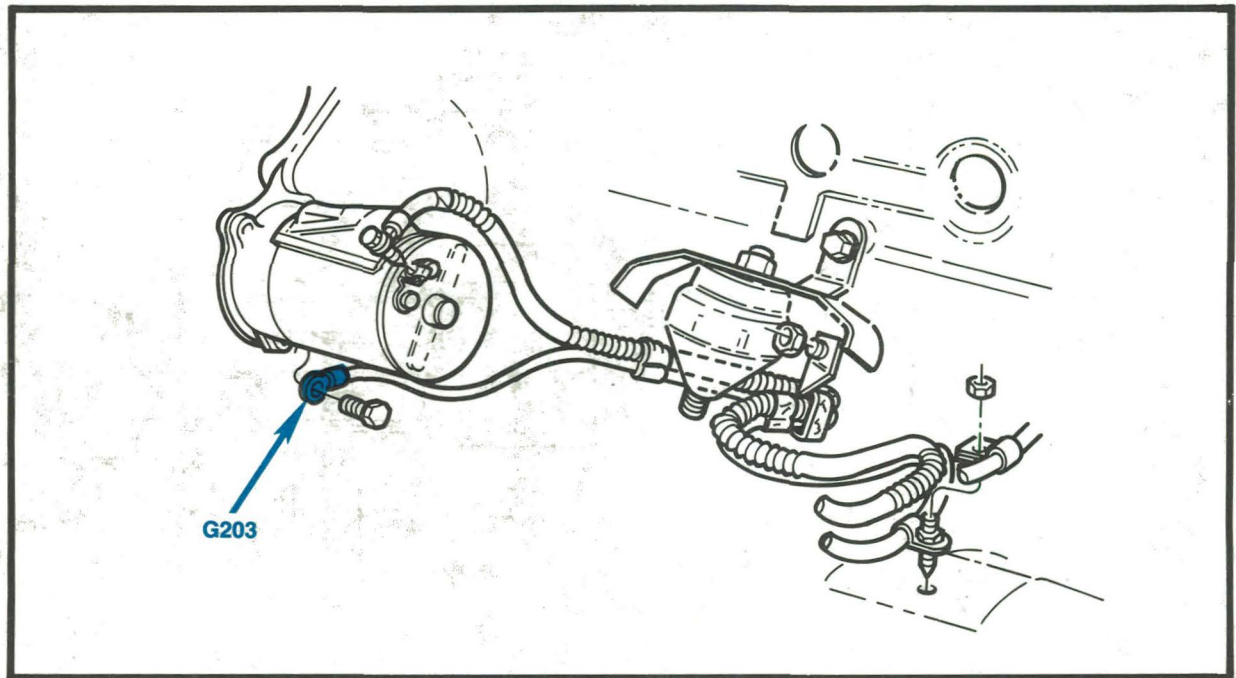
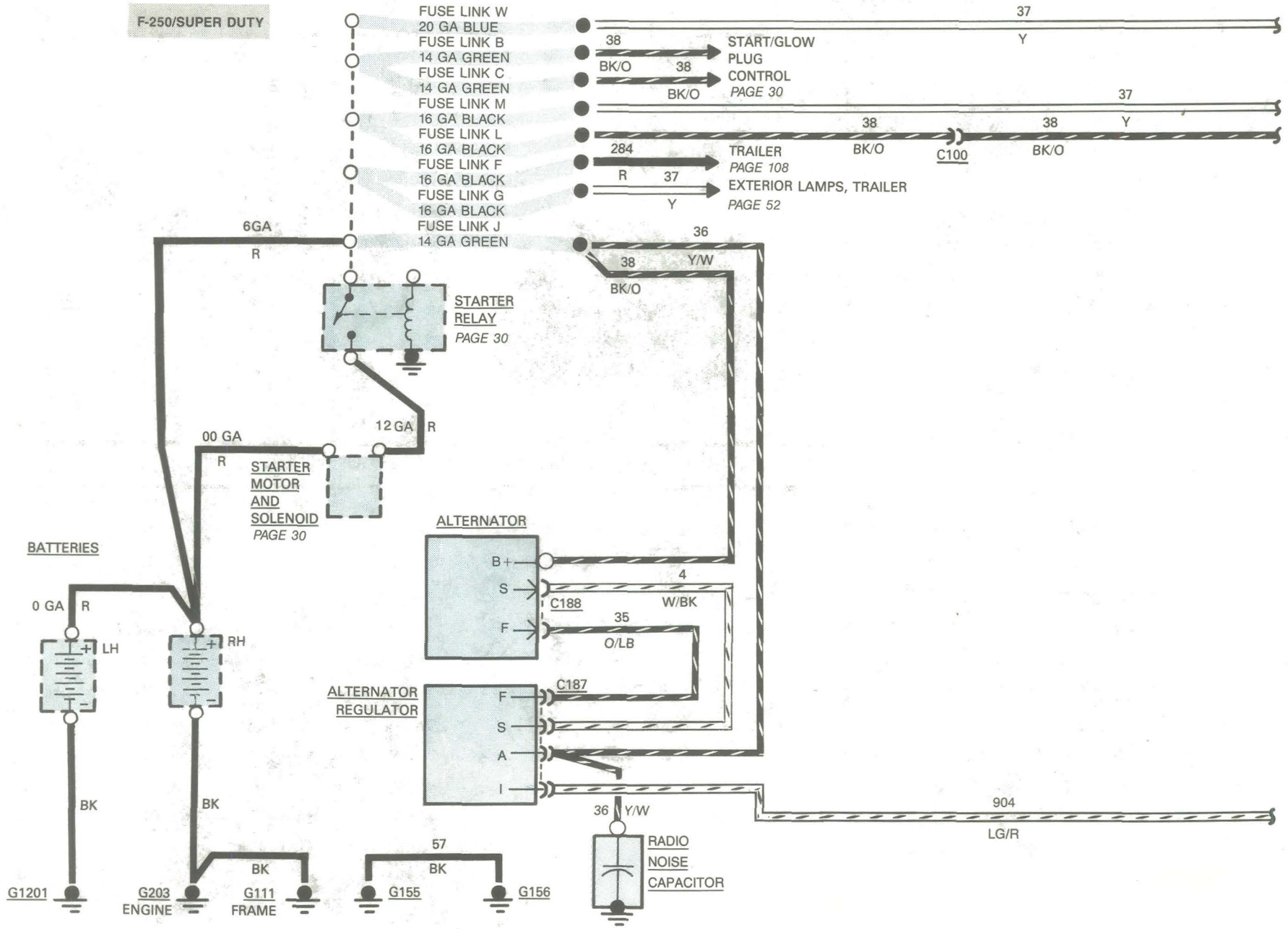
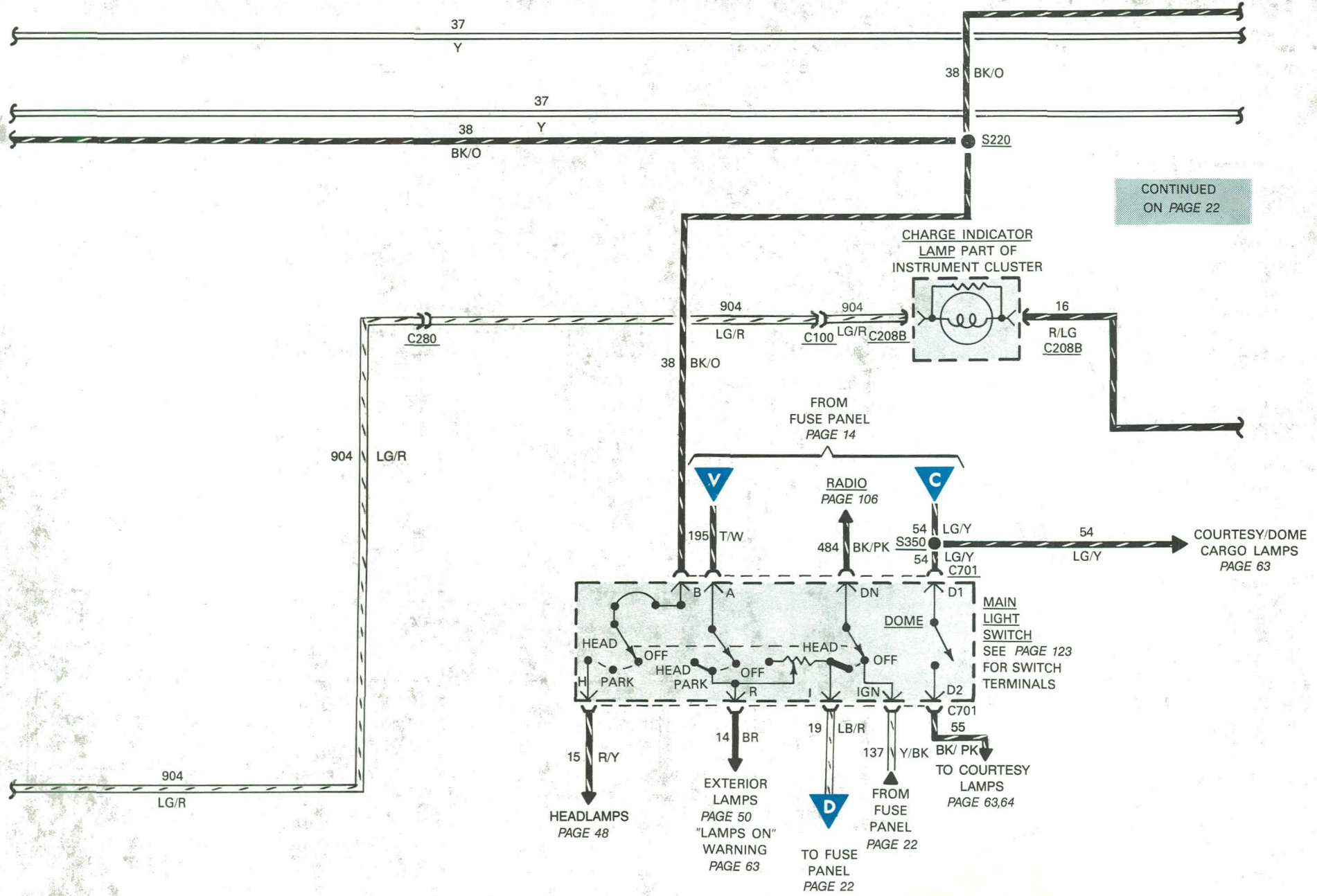

Figure 2 — Lower RH Side of Engine (4.9L 6 Cyl. ONLY)

# 20 CHARGE/POWER DISTRIBUTION (DIESEL)



# CHARGE/POWER DISTRIBUTION (DIESEL) 21



CONTINUED  
ON PAGE 22

# 22 CHARGE/POWER DISTRIBUTION (DIESEL)

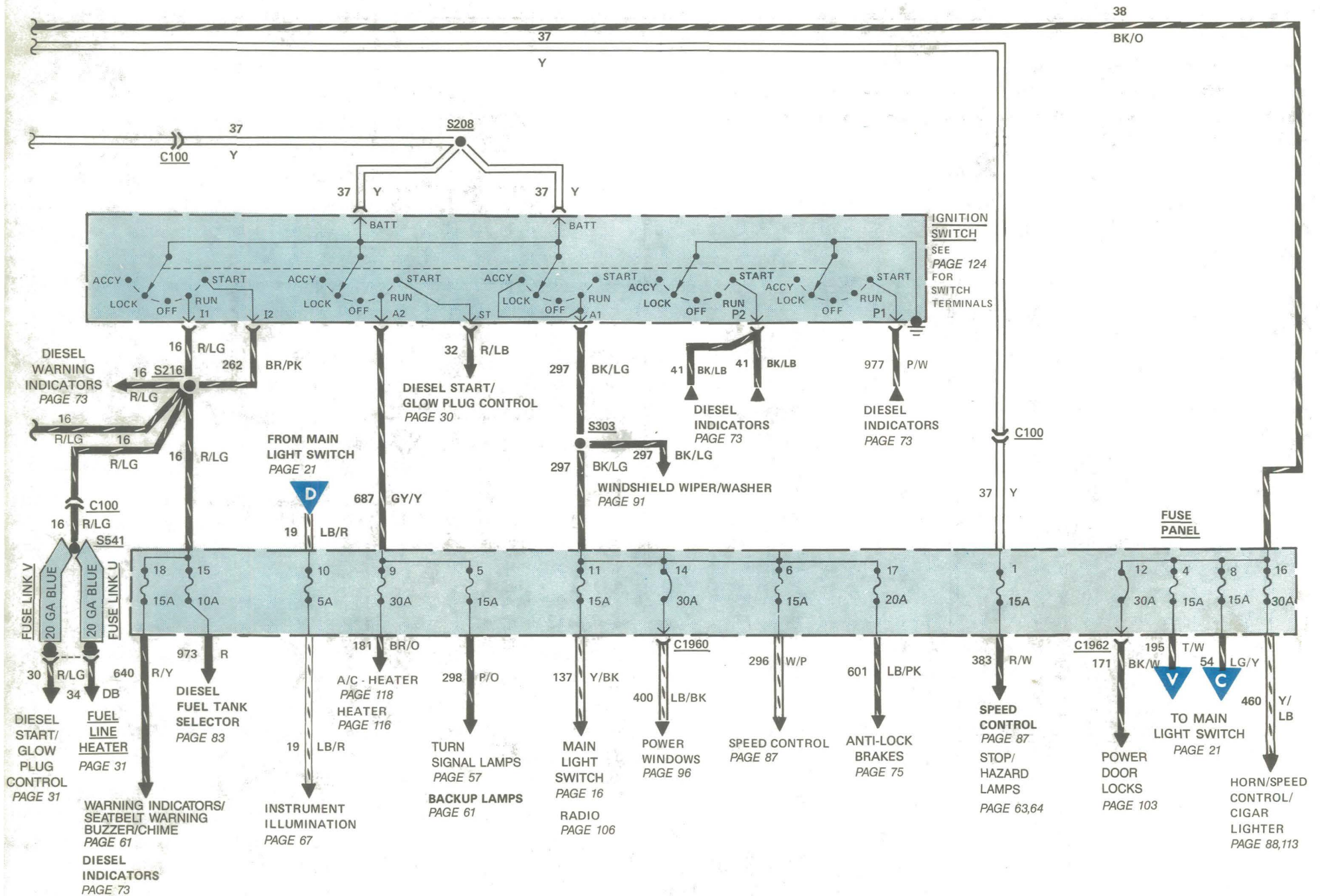

## HOW THE CIRCUIT WORKS

The **Batteries, Alternator and Voltage Regulator** make up the **Diesel Charging System**.

With the **Ignition Switch** in RUN, **Battery** current flows through the solid-state **Electronic Control of the Voltage Regulator**. The **Electronic Control** applies **Battery** voltage to the **Alternator** field.

With current in the field and the rotor turning, the **Alternator** stator produces a DC voltage at B+ terminals (to **Battery**).

If the alternator output voltage is greater than the battery voltage, current will flow from the alternator to the **Battery** as well as to the vehicle electrical load.

If the alternator voltage is less than the battery voltage, current will flow from the battery to help supply the vehicle load.

Refer to section 31-01 of the shop manual.

## COMPONENT LOCATION

Page-  
Figure

Charge Indicator .....	In instrument cluster .....
Fuse Links B, C, F, G, J, L, M, W .....	Near starter relay .....
Fuse Links U, V .....	RH fender apron .....
Glow Controller .....	On rear of engine ..... 43-1
Radio Noise Capacitor ...	Near voltage regulator .....
Starter Relay .....	RH inner fender .....

Refer to the **Location Index** in the back of the manual for connector, ground, and splice descriptions and locations.

## TROUBLESHOOTING HINTS

CONDITION	POSSIBLE CAUSE	ACTION
<ul style="list-style-type: none"> <li>Improper Charging</li> </ul>	<ul style="list-style-type: none"> <li>Loose/worn alternator belt</li> <li>Defective/dead battery</li> <li>Fuse Link J open at starter relay</li> <li>Poor connection between battery terminals and cable clamps/damaged cables</li> </ul>	<ul style="list-style-type: none"> <li>Tighten/replace</li> <li>Replace battery</li> <li>Visually check for open in link, replace</li> <li>Clean, tighten and/or replace</li> </ul>
<ul style="list-style-type: none"> <li>Alternator Warning Indicator remains on after initial start up</li> </ul>	<ul style="list-style-type: none"> <li>Poor connection on Alternator, Regulator, Starter Relay, and/or Alternator Output Control Relay</li> </ul>	<ul style="list-style-type: none"> <li>Make sure connections are tight and free of debris and refer to shop manual section 31-01, Charging System Diagnosis</li> </ul>

# 24 CHARGE/POWER DISTRIBUTION (DIESEL)

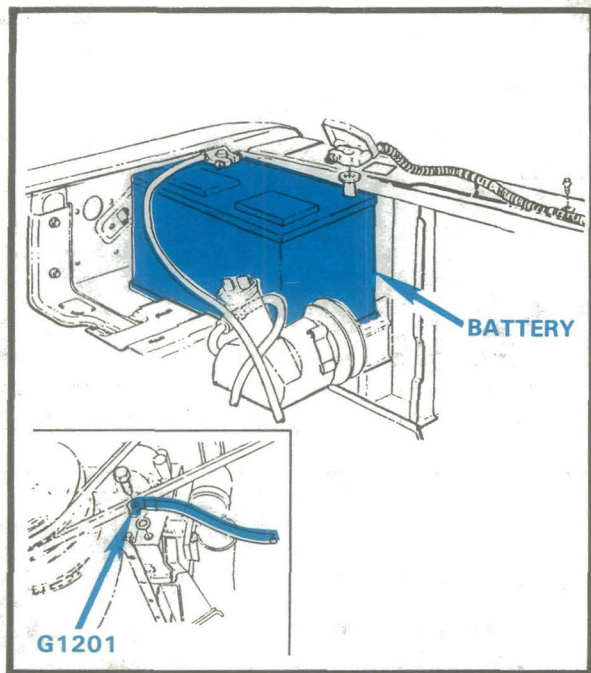

Figure 1 - Battery Wiring LH Side (Diesel Engine)

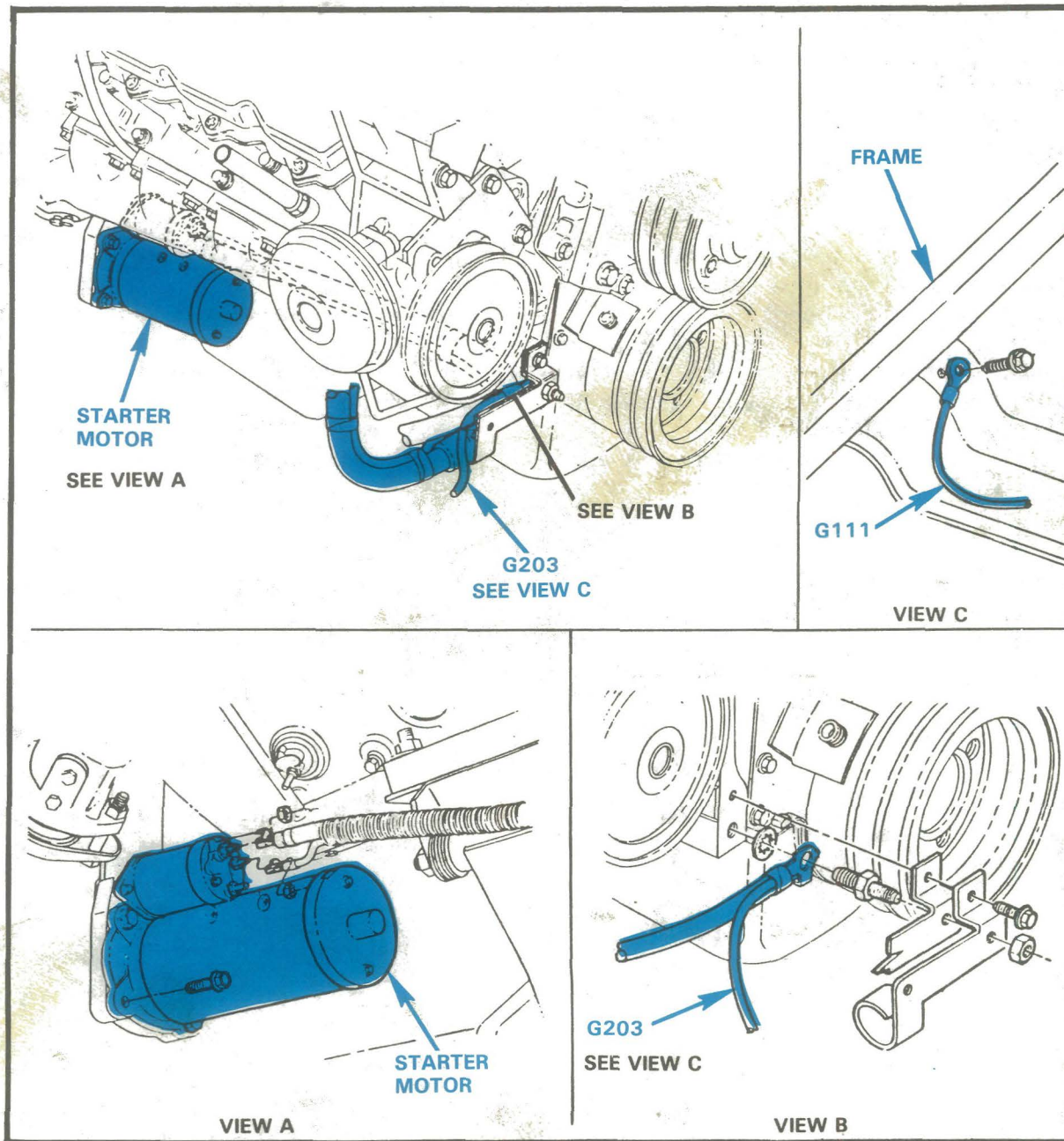
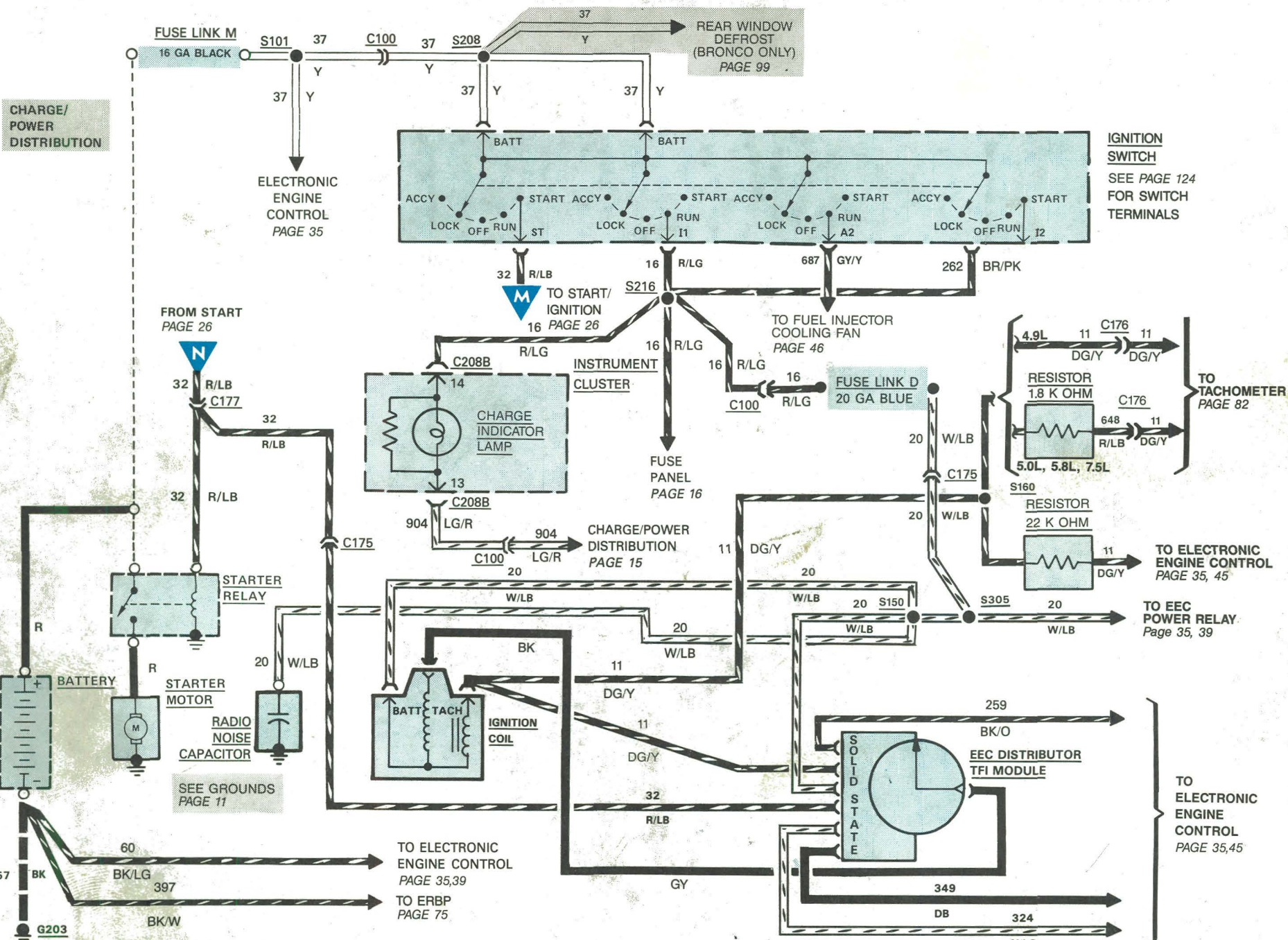

Figure 2 - Starter Wiring (Diesel Engine)



# 26 START/IGNITION

## WITH MANUAL TRANSMISSION

FROM START/IGNITION AND  
START/GLOW PLUG CONTROL  
PAGE 25 (START/IGNITION)  
30 (START/GLOW PLUG CONTROL)

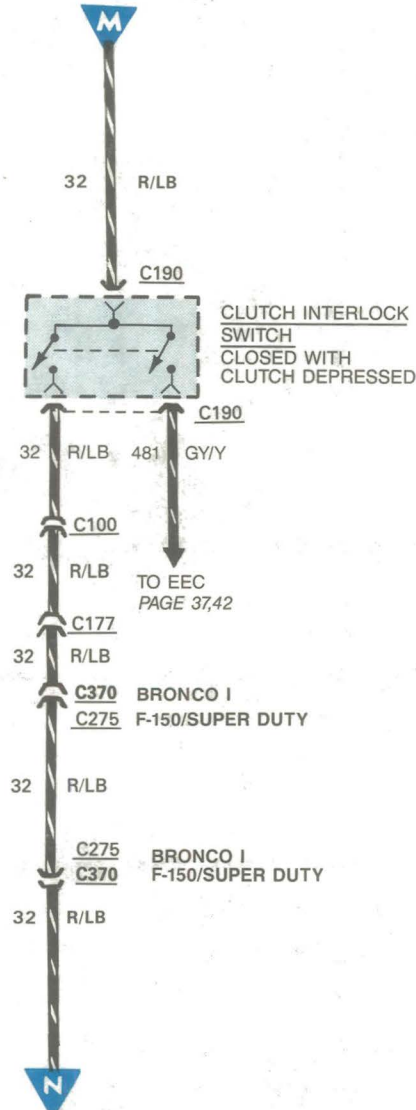

TO START/IGNITION  
PAGE 25  
START/GLOW PLUG  
PAGE 30

## WITH AUTOMATIC TRANSMISSION

FROM START/IGNITION AND  
START/GLOW PLUG CONTROL  
PAGE 25 (START/IGNITION)  
30 (START/GLOW PLUG CONTROL)

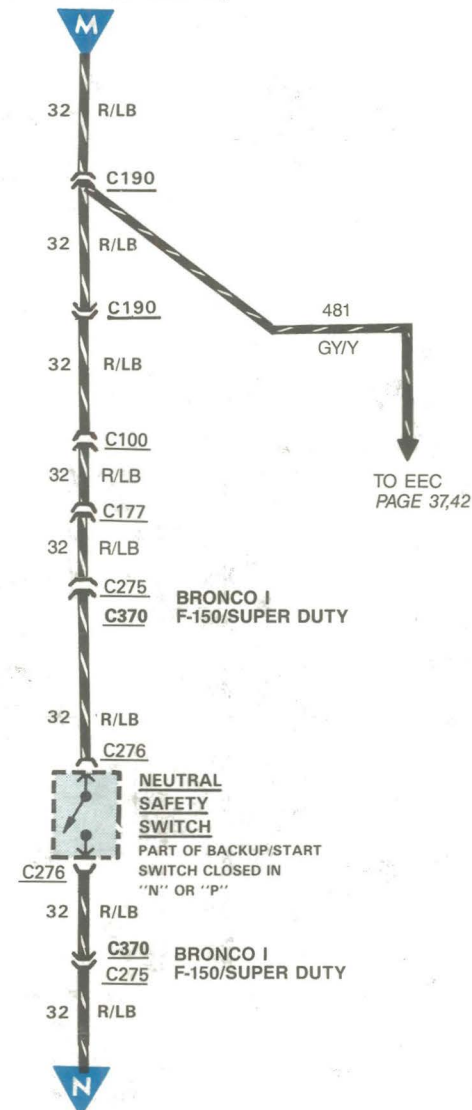

TO START/IGNITION  
PAGE 25  
START/GLOW PLUG  
PAGE 30

# START

## HOW THE CIRCUIT WORKS

The **Battery, Starter Motor, Starter Relay,** and **Ignition Switch** make up the **Starting System**. In vehicles with automatic transmissions, the **Neutral Safety Switch** must be closed (**Park** or **Neutral**) in order to operate the **Starter Motor**. In vehicles with manual transmissions, the **Clutch Interlock Switch** must be closed in order to operate the **Starter Motor**.

Turning the **Ignition Switch** to **START** sends battery voltage to the **Starter Relay** coil and energizes the relay. Voltage from the **Battery** is then applied directly through the **Starter Relay** to the **Starter Motor** to start the engine.

When the **Ignition Switch** is in **START**, battery voltage is applied to both the **START** (circuit 32) and **RUN** (circuit 20) terminals of the **Thick Film Integrated Ignition (TFI) Module**. When the **Ignition Switch** is in the **RUN** position, the voltage on circuit 32 drops to zero.

## COMPONENT LOCATION

Page-  
Figure

Charge Indicator .....	Part of instrument cluster .....	
Clutch Interlock Switch ...	Near top of clutch pedal .....	34-1
Fuse Link M .....	At starter relay .....	
Fuse Link D .....	At C175 LH engine compartment .....	
Ignition Coil .....	On engine .....	36-3, 37-4, 39-9
Ignition Module .....	At distributor .....	36-3
Neutral Safety Switch ....	Part of automatic transmission .....	
Radio Noise Capacitor ....	At ignition coil .....	
Starter Relay .....	RH inner fender .....	

Refer to the **Location Index** in the back of the manual for connector, ground, and splice descriptions and locations.

## TROUBLESHOOTING HINTS

CONDITION	POSSIBLE CAUSE	ACTION
• Starter does not operate	• No voltage at starter Relay/Starter	• Check for open at Fuse Link M
• Starter cranks slowly/ solenoid clicks	• Low charged battery/ defective starter	• Check for clean tight connection at battery/worn battery or repair/replace starter
• No spark at plug	• Faulty ignition primary circuitry	• Check all TFI connections replace
• Poor engine performance	• Engine operating with a fixed 10° BTDC spark timing and the EGR system is not operating	• System operating in "fail mode" *see EEC system note

**\*NOTE:** Because of the complexity of the EEC system, special test equipment is required to diagnose it. Refer to the **ENGINE/EMISSIONS DIAGNOSIS MANUAL, VOLUME H** for diagnostic procedures.

## IGNITION

### HOW THE CIRCUIT WORKS

The **EEC Distributor** does not have a magnetic pickup or spark advance. Instead all ignition timing is controlled by the **Electronic Engine Control (EEC) Module**. Refer to the Engine/Emissions Diagnosis Manual Volume H for complete details.

The **EEC IV Ignition System** includes a **Thick Film Integrated Ignition (TFI) Module**, which is mounted on the side of the **Distributor**. The **Distributor** is mounted on the top front of the engine and directly driven by the engine camshaft.

When the engine is running:

- The pickup in the **Distributor** provides the signal input through the **TFI Module** to the **EEC Module**, which returns a signal to the **TFI Module**. The **TFI Module** switches current on and off in the primary circuit of the **Ignition Coil** according to the distributor pulses.
- Each interruption of primary current makes the **Ignition Coil** secondary produce an open circuit high-voltage pulse of up to 40,000 volts.
- High voltage pulses are transmitted to the **Distributor**, which sends them to fire the spark plugs.

The **TFI Module** can function alone if the path between the **EEC Module** and the **TFI Module** is broken. When timing information is not received from the **EEC Module**, the **TFI Module** sets a fixed base timing rate depending on engine calibration.

Refer to Engine/Emissions Diagnosis Manual, Volume H.

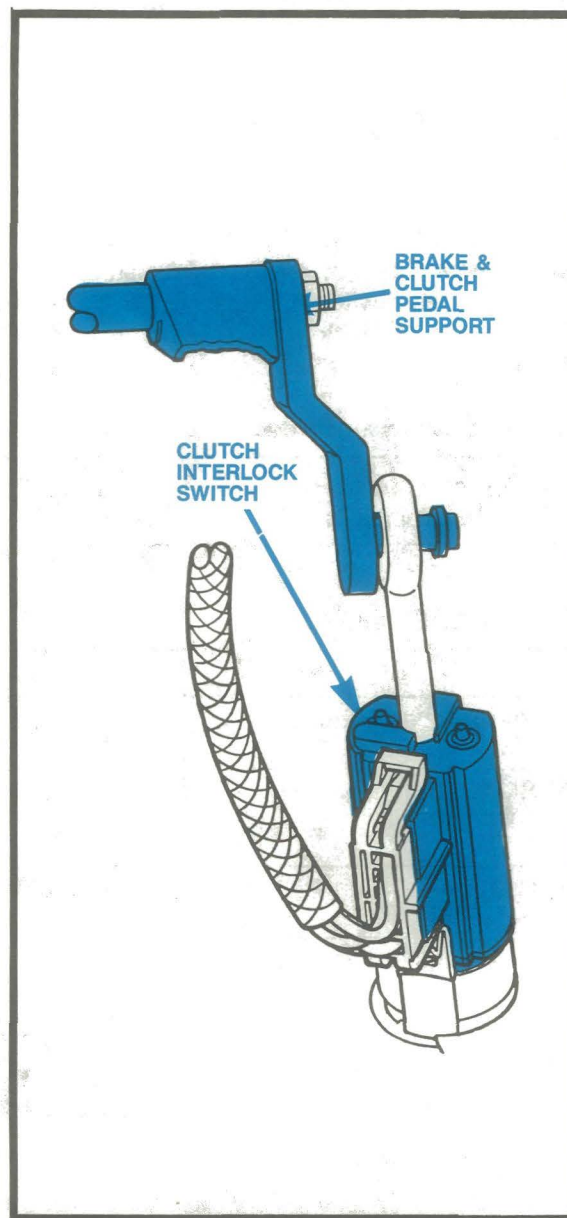

Figure 1 — Clutch Interlock Switch

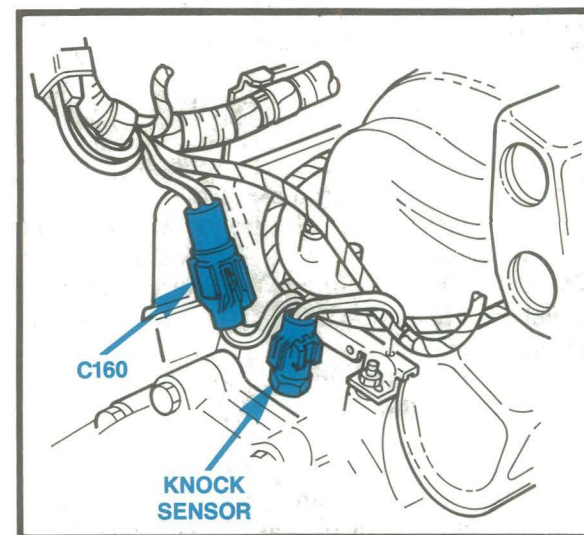

Figure 2 — Knock Sensor Location — 5.0L EFI

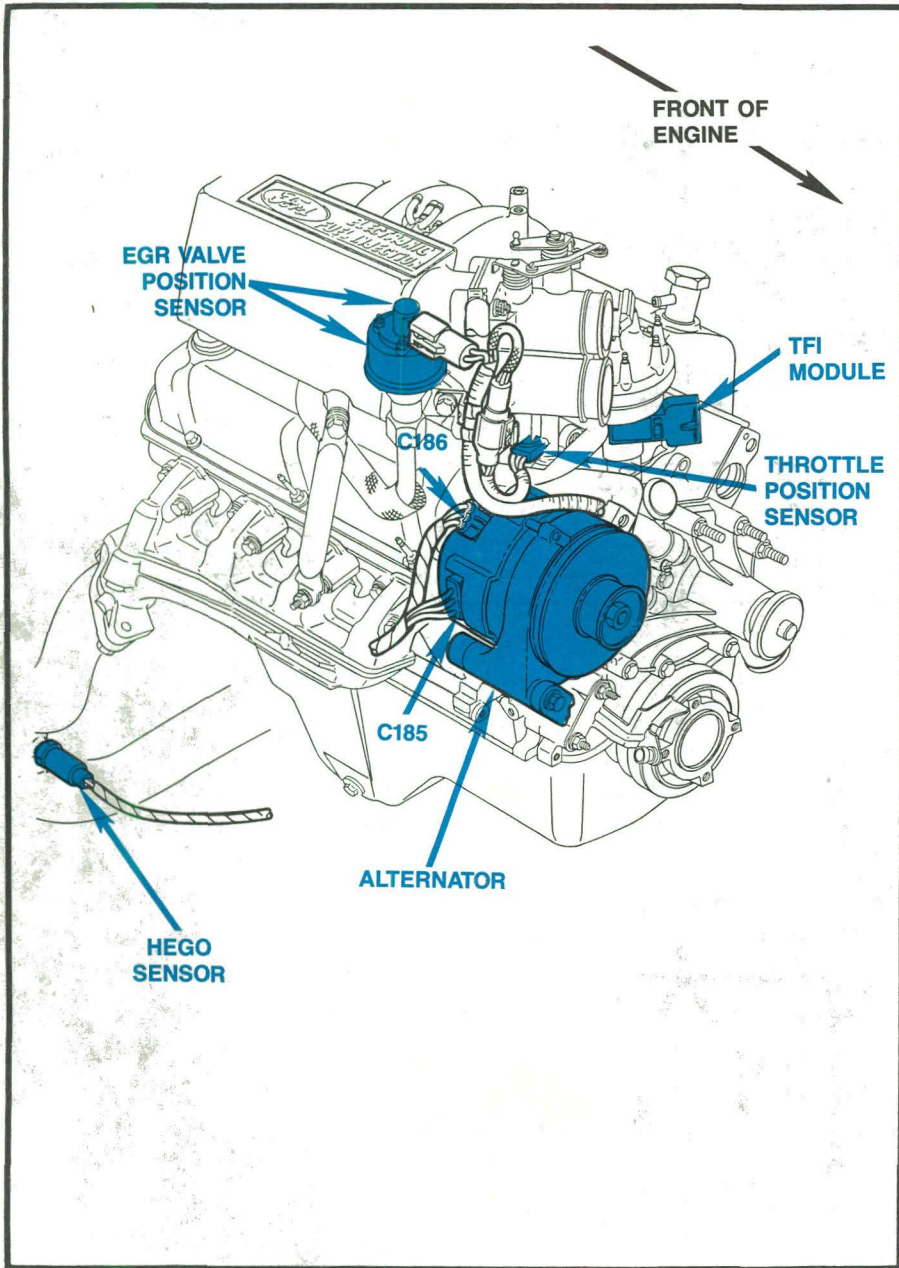

Figure 3 — RH View 5.0L Engine (50 States) (EEC-IV)

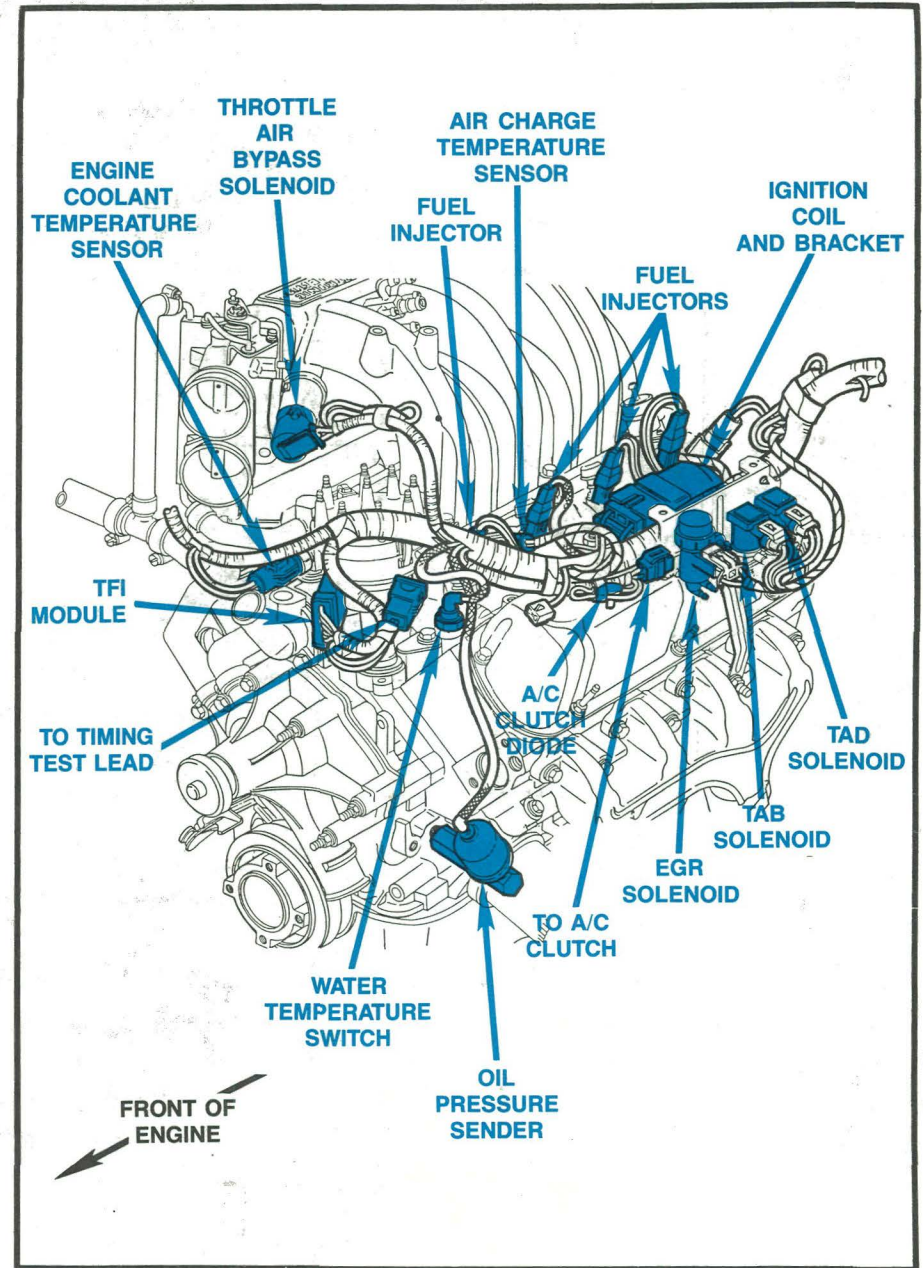
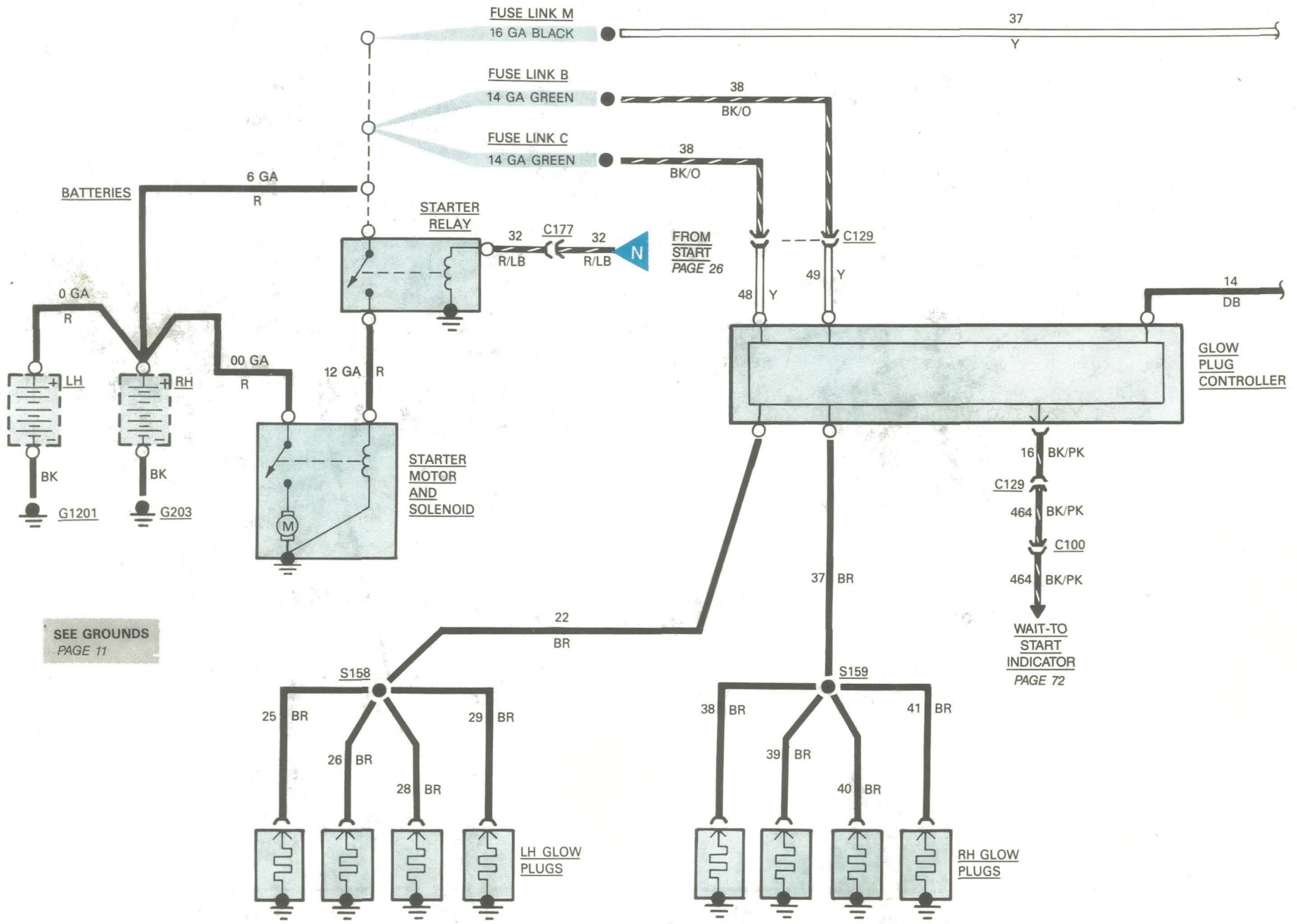
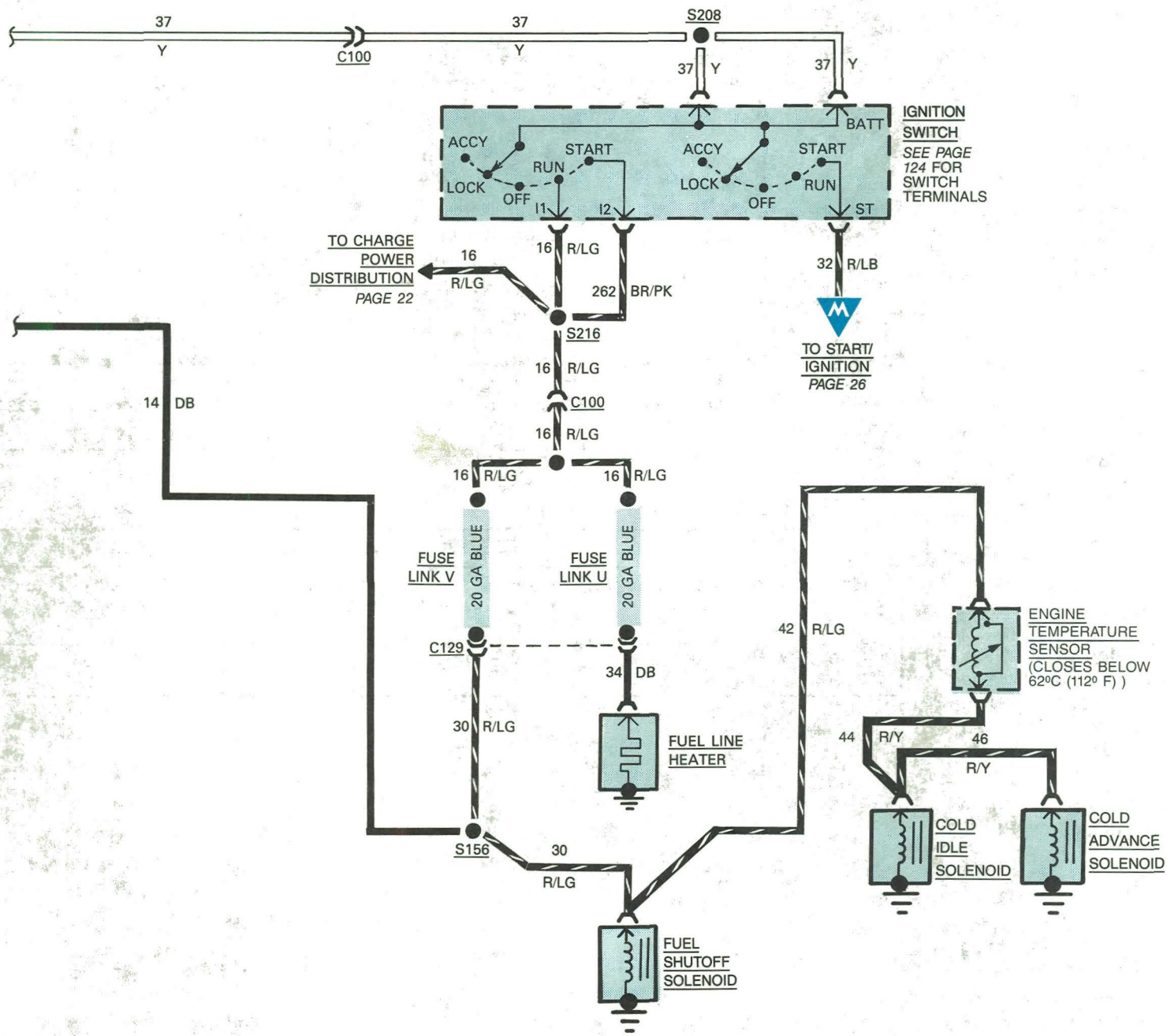

Figure 4 — LH View 5.0L Engine (50 States) (EEC-IV)

# 30 START/GLOW PLUG CONTROL/RUN (DIESEL)



# START/GLOW PLUG CONTROL/RUN (DIESEL)



# 32 START/GLOW PLUG CONTROL/RUN (DIESEL)

## HOW THE CIRCUIT WORKS

The Diesel Start/Glow Plug Control circuit applies power to the **Glow Plugs** which heat the combustion chambers, so that the cold diesel engine can be started.

### Glow Plug Control

The solid state **Glow Plug Controller** is attached to the top of the engine block. It controls glow plug pre-glow and after-glow time. The **Glow Plug Controller** controls the circuit's operation by sensing engine temperature, glow plug voltage, and after-glow voltage from start/run circuit.

When the **Ignition Switch** is turned to RUN, voltage from **Fuse Link V** is applied through the **Glow Plug Controller** to the **Glow Plugs Wait to Start Indicator Lamp**.

The glow plugs are heated from zero to fifteen seconds, depending on engine coolant temperature. After this time, the controller cycling switch opens and turns OFF the **Glow Plugs Wait to Start Indicator Lamp**.

The **Glow Plugs** are now warm enough for the engine to be started.

At the same time the **Ignition Switch** is turned to Run, voltage from **Fuse Link V** is applied to the After-Glow Timer (located inside the Glow Plug Controller). The After-Glow Timer cycles the **Glow Plugs** for up to two minutes, depending on engine temperature. The After-Glow Timer then opens. The **Wait to Start Indicator Lamp** will not light during After-Glow period.

If the ignition switch is turned **OFF**, it can be turned **ON** immediately and the **Glow Plug** heating cycle will start again.

### Diesel Start/Run

The diesel engine uses two batteries to provide extra power for starting and glow plug heating. Power is applied from the batteries through heavy gauge wires to the Starter Solenoid in the Starter motor assembly. When the

## COMPONENT LOCATION

Page-  
Figure

Cold Advance Solenoid ..	In injection pump .....	
Cold Idle Solenoid .....	On injection pump .....	
Engine Temperature Switch .....	At left front end of engine .....	
Fuel Line Heater .....	RH side of engine .....	44-1
Fuel Shut-Off Solenoid ..	In injection pump .....	
Fuse Link B, C, M .....	Near starter relay .....	
Fuse Link U, V .....	RH fender apron .....	
Glow Plug Controller ....	LH rear top of engine .....	43-1
Glow Plug Indicator .....	In diesel warning lamp module .....	
Starter Relay .....	RH fender .....	

Refer to the **Location Index** in the back of the manual for connector, ground, and splice descriptions and locations.

## TROUBLESHOOTING HINTS

CONDITION	POSSIBLE CAUSE	ACTION
• No Glow Plugs operate	• No voltage at Y wire connector of Glow Plug Controller	• Check Fuse Links B and C and check wiring
• One Glow Plug does not operate	• No voltage at BR wire of Glow Plug	• Check for open in BR wire

**Glow Plug Indicator** goes out, the **Ignition Switch** can be turned to START. With the transmission selector in park or neutral (automatic transmission), or the clutch pedal depressed (manual transmission), power is applied to the **Starter Relay**. The relay applies power to the solenoid coil which closes contacts to apply battery power to the starter motor.

With the **Ignition Switch** in Start or Run, voltage is supplied to the **Fuel Line Heater**, **Fuel Shut-Off Solenoid**, and the **Engine Temperature Switch** through **Fuse Links U and V**.

The **Fuel Line Heater** is wrapped around the fuel line. It heats the diesel fuel to melt any wax which might clog the filter.

which might clog the filter. The heater has an internal thermostat to turn it on as needed.

The **Fuel Shut-Off Solenoid** controls the flow of fuel into the Injection Pump. With the **Ignition Switch** in Start or Run, the solenoid is energized, and fuel is allowed to flow into the Injection Pump. When the **Ignition Switch** is turned Off, the solenoid is de-energized, fuel flow stops, and the engine stops running.

The **Engine Temperature Switch** provides voltage to the **Cold Advance Solenoid** and the **Cold Idle Solenoid**. When engine temperature is below 62°C (112°F), the **Engine Temperature Switch** is closed. When the **Ignition Switch** is turned to Start or Run, the Solenoids are ener-

gized, advancing Injection Pump timing and Engine Idle, allowing the engine to run more smoothly when cold. When the engine temperature reaches 62°C (112°F), the **Engine Temperature Switch** opens. This de-energizes the Solenoids, returning the Timing and Idle to normal.

Refer to **Engine/Emissions Diagnosis Manual, volume H** for additional diagnosis information.

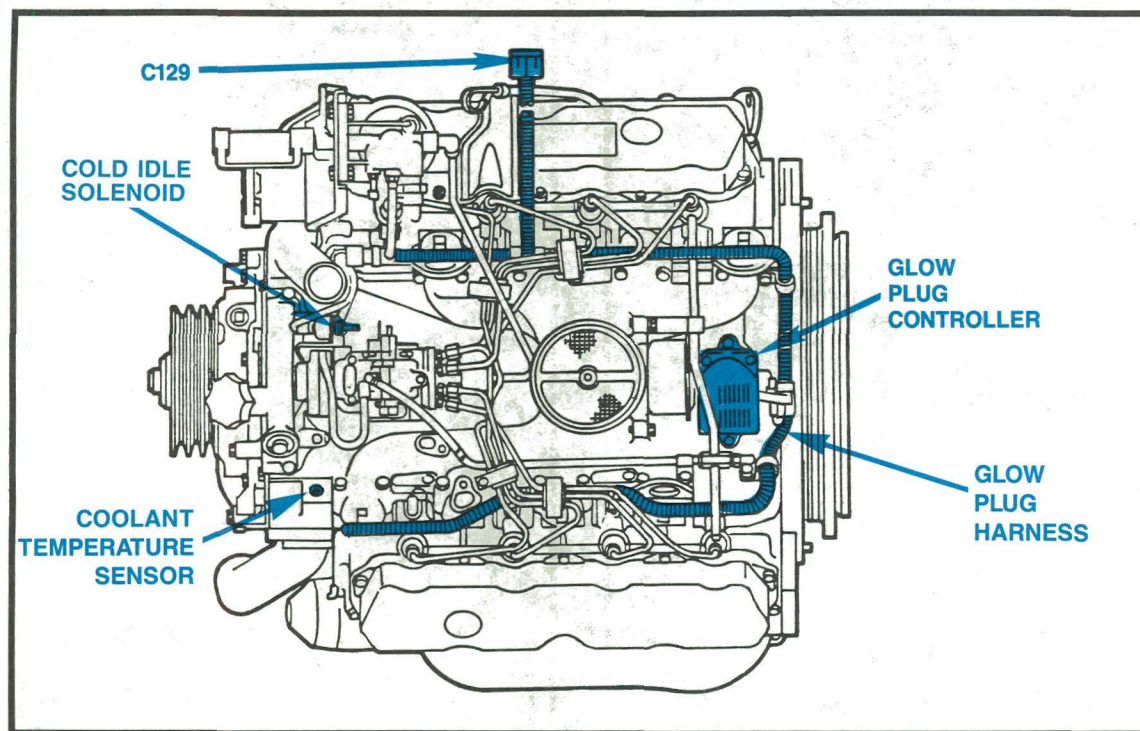

Figure 1 — Glow Plug Controller

# 34 START/GLOW PLUG CONTROL/RUN (DIESEL)

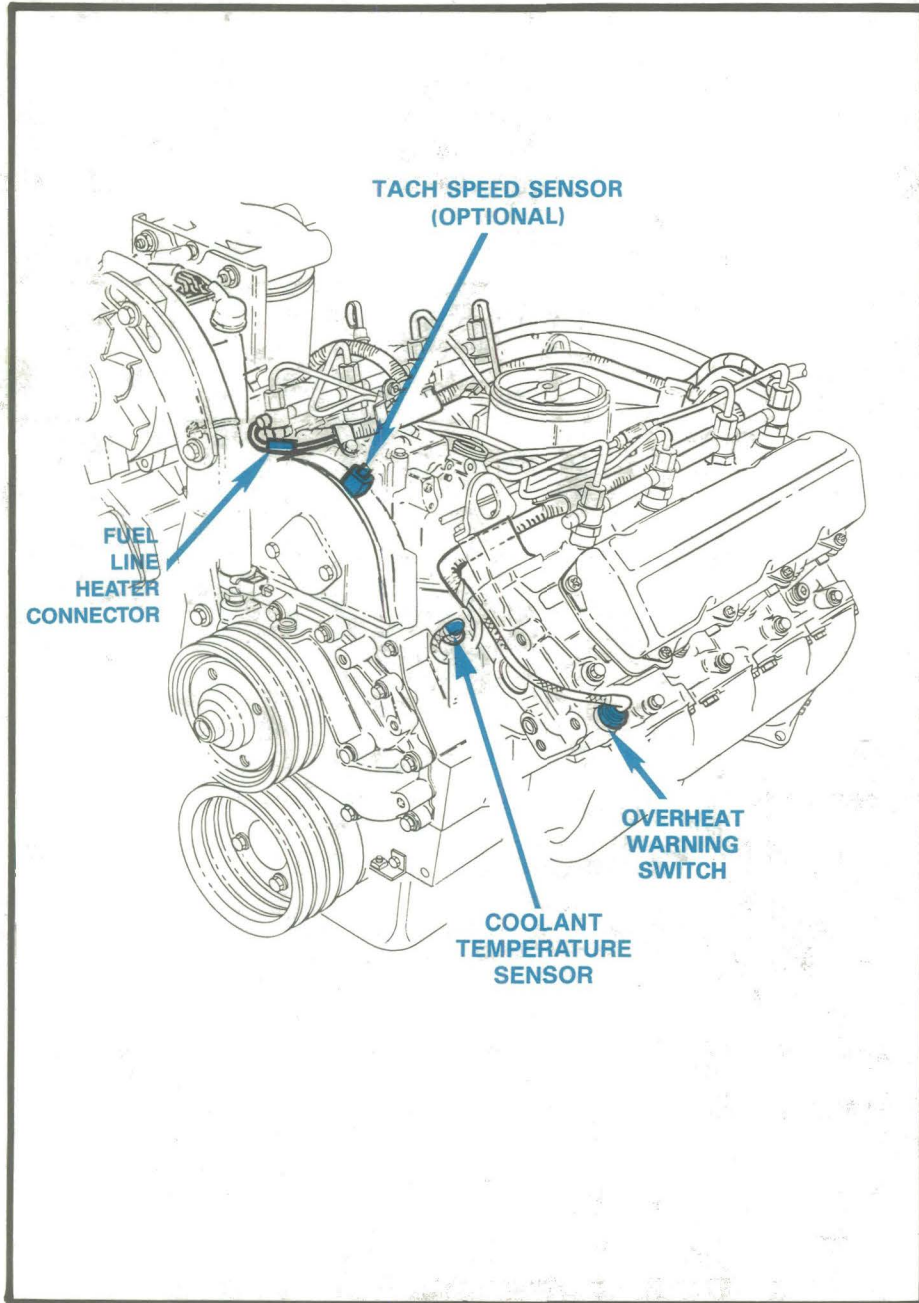

Figure 2 — LH Side of 7.3L Diesel Engine

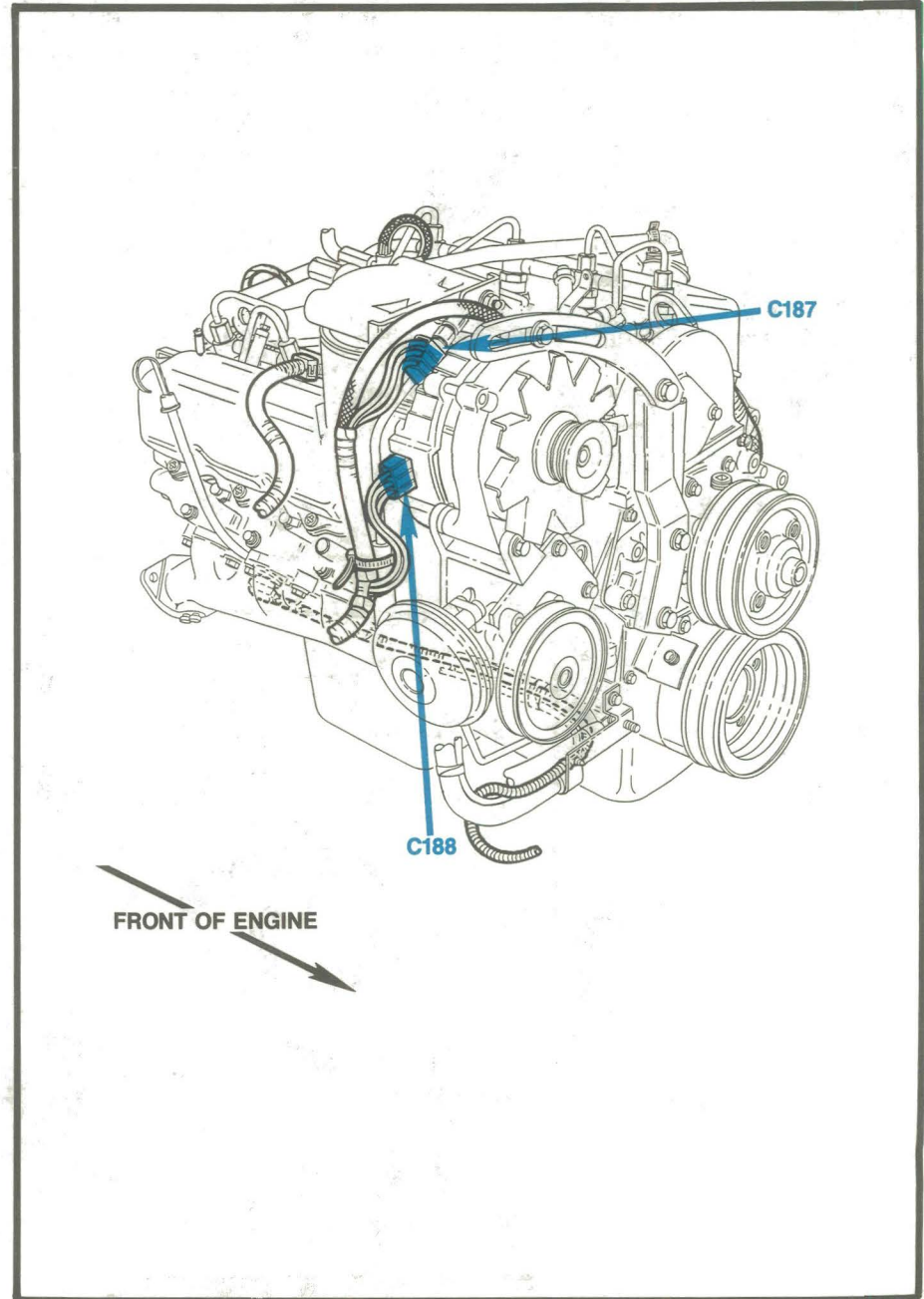
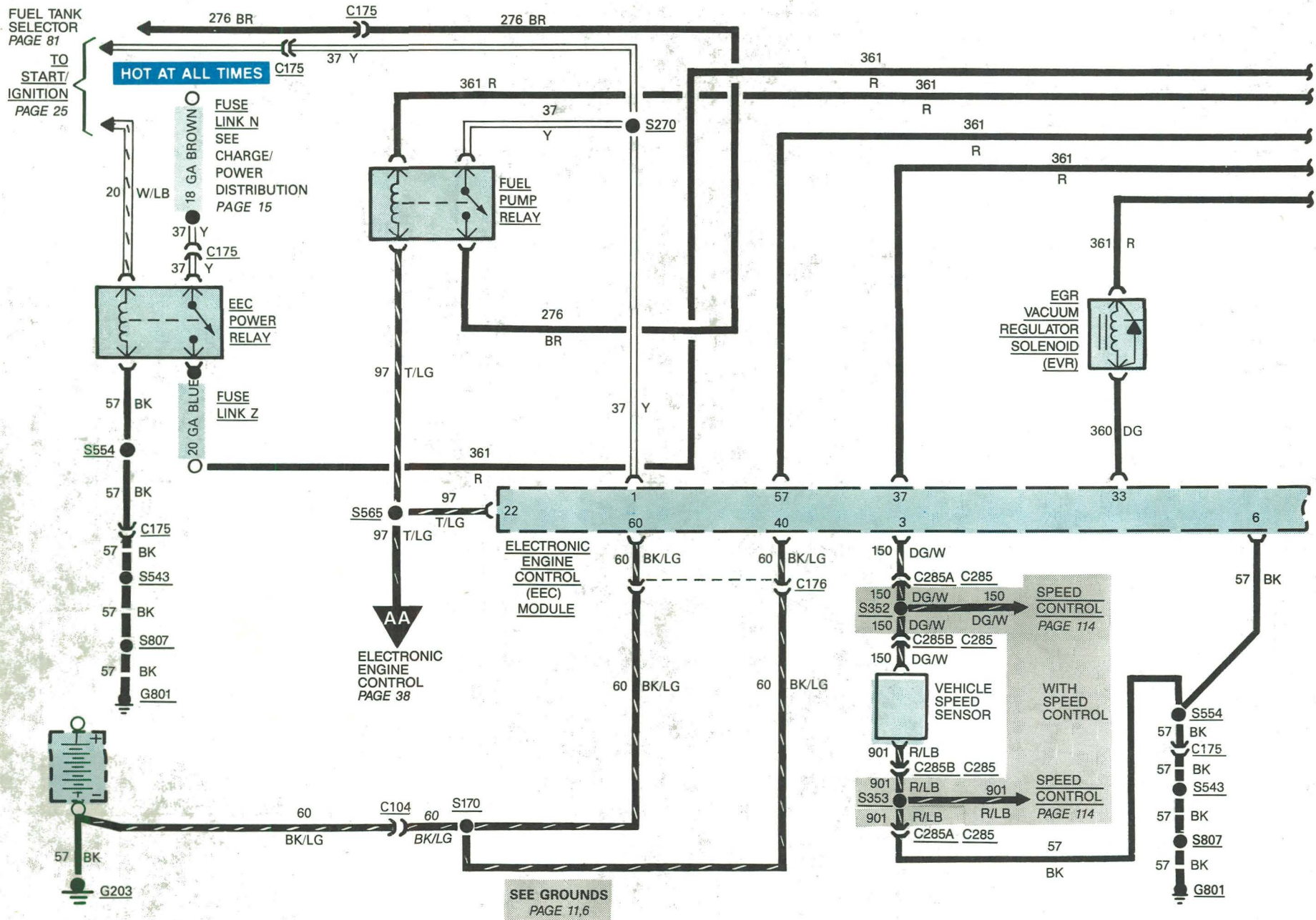
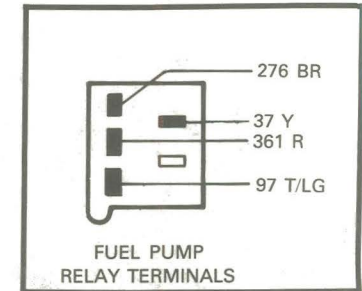
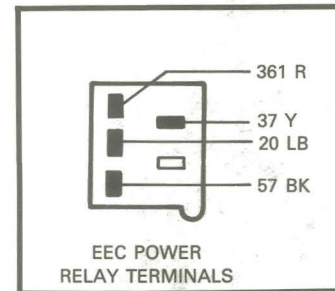
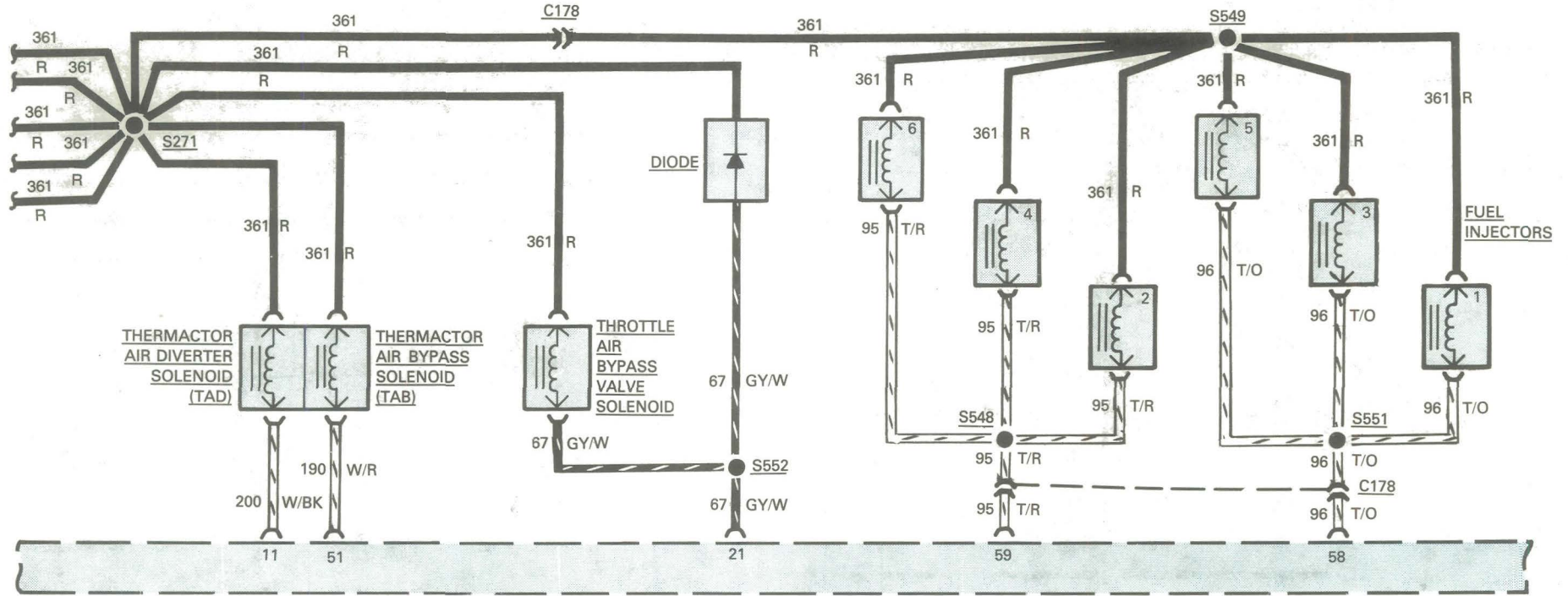
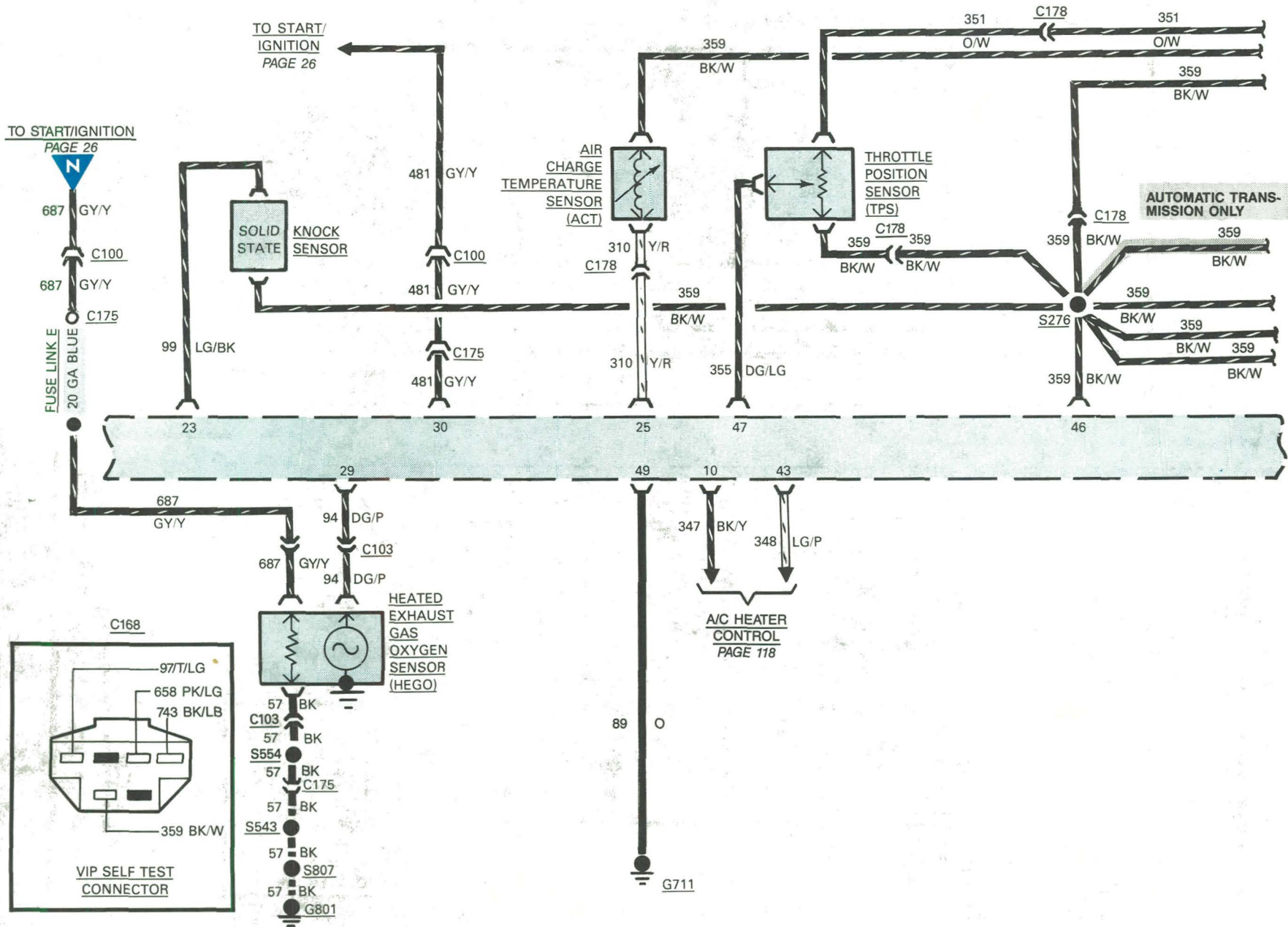

Figure 3 — RH Side of 7.3L Diesel Engine



# 36 ELECTRONIC ENGINE CONTROL (EEC) (4.9L ONLY)





# 38 ELECTRONIC ENGINE CONTROL (EEC) (4.9L ONLY)

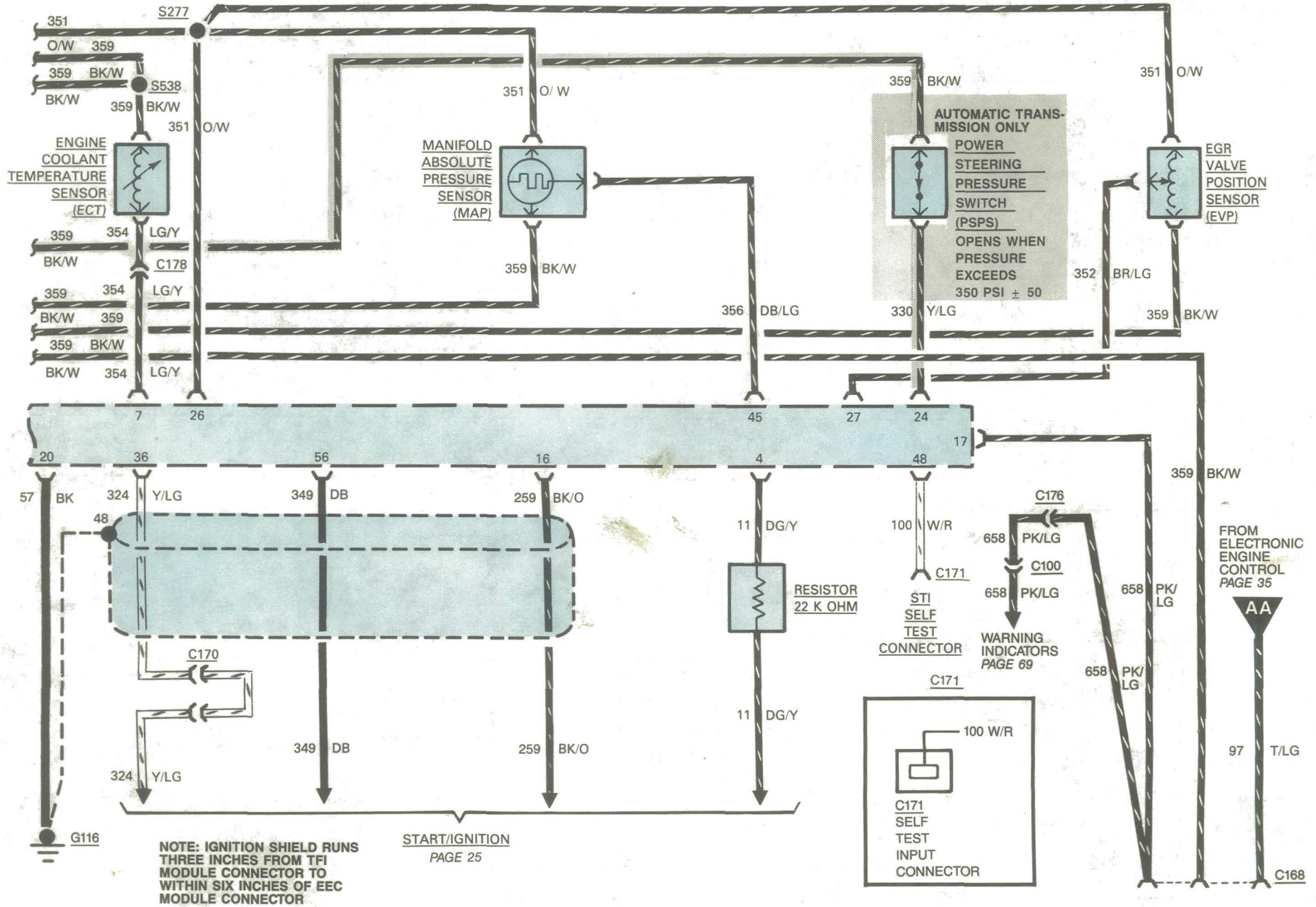



# 40 ELECTRONIC ENGINE CONTROL (EFI 5.0L, 5.8L, 7.5L)

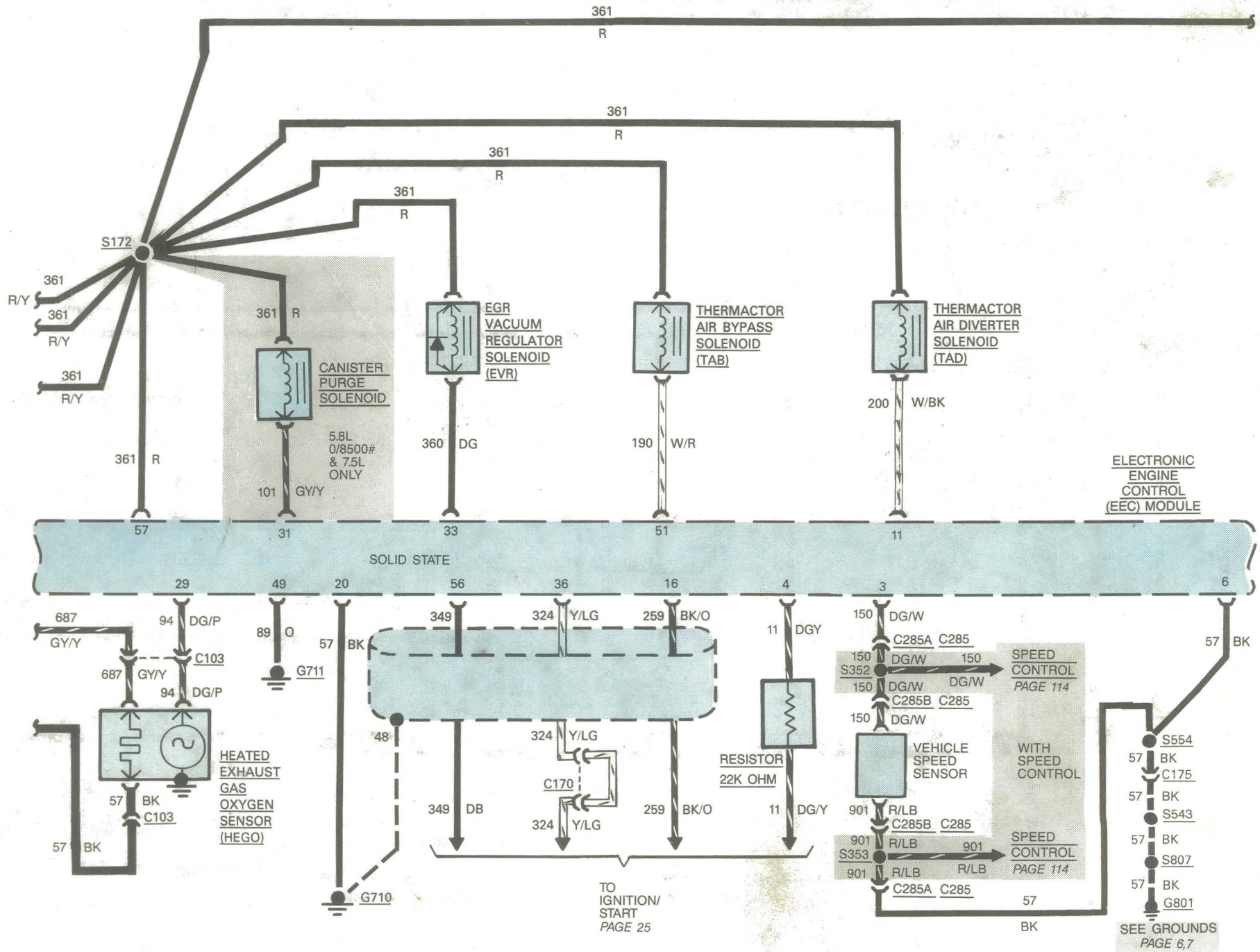

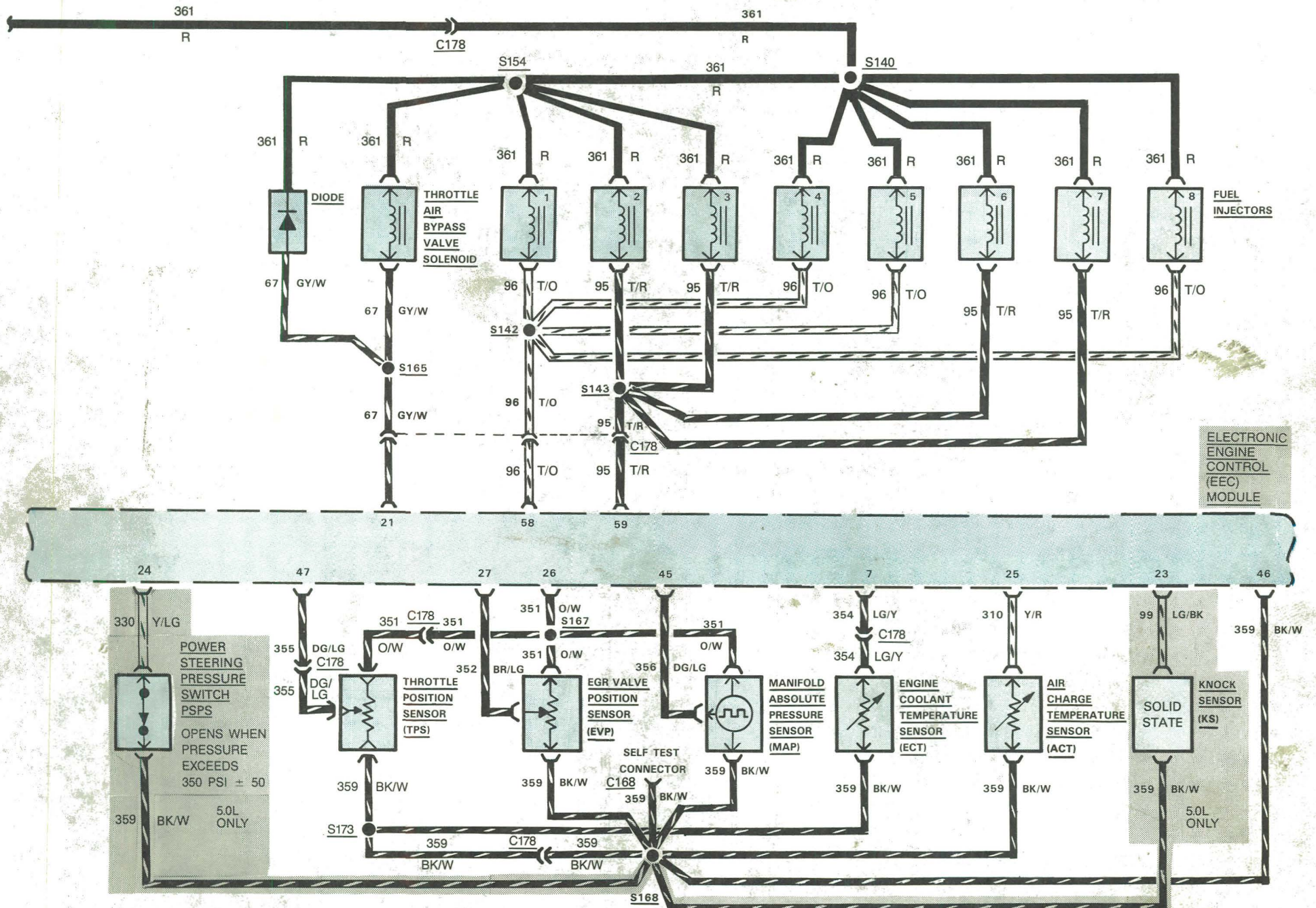

# 42 ELECTRONIC ENGINE CONTROL (EFI 5.0L, 5.8L, 7.5L)

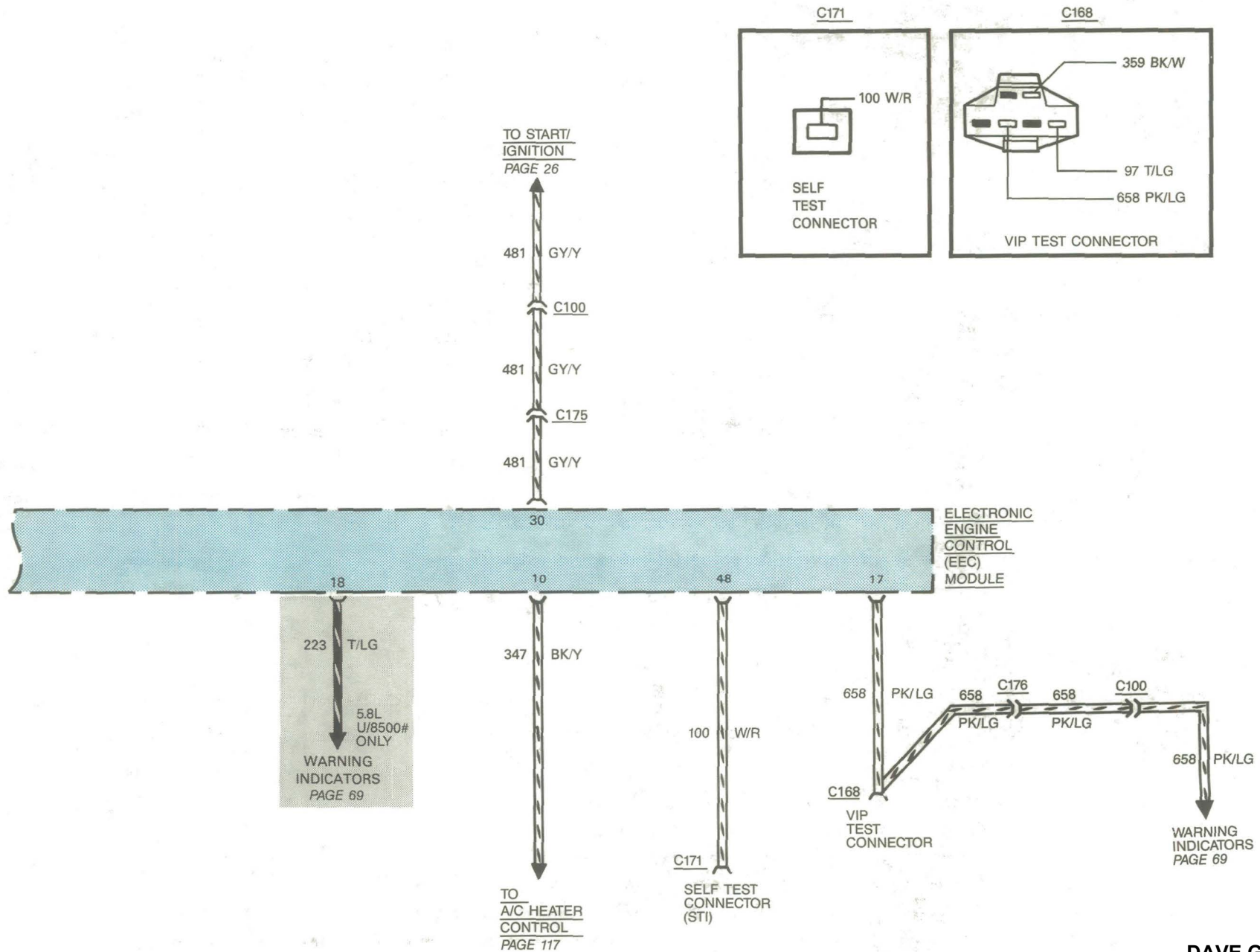

## HOW THE CIRCUIT WORKS

The **Electronic Engine Control-IV System (EEC-IV)** is a controlling system designed to optimize tailpipe emissions, fuel economy, driveability, and performance. This is accomplished by means of an on-board **Electronic Engine Control (EEC) Module**, which receives input from various sensors. The **EEC Module** makes computations based on these inputs, then sends controlling signals to various components to achieve desired air/fuel ratio, ignition timing, EGR flow, **Thermactor** air flow and idle speed.

### System Inputs

The **Profile Ignition Pick-Up (PIP) Sensor** supplies crankshaft position and frequency information to the **EEC Module** (from the distributor).

The **Throttle Position Sensor (TPS)** provides the **EEC Module** with a signal proportional to the angle of the throttle plate.

The **Engine Coolant Temperature (ECT) Sensor** monitors the temperature of the engine coolant and provides a corresponding signal to the **EEC Module**.

The **Heated Exhaust Gas Oxygen (HEGO) Sensor** sends a voltage signal to the **EEC Module** which indicates the oxygen level in the exhaust gases.

The **Manifold Absolute Pressure (MAP) Sensor** measures the pressure in the intake manifold and provides this information as a variable frequency signal to the **EEC Module**. With the ignition switch in the Key-On/Engine Off position, the MAP sensor measures the Barometric Pressure in the intake manifold. With the ignition switch in the Key-On/Engine-Running position, the MAP sensor measures the varying pressure (Vacuum) in the intake manifold.

The **Power Steering** pressure switch signals the **EEC Module** when the power steering pressure increases the load on the engine, to increase the idle speed (4.9L Auto. Trans. and 5.0L only).

## COMPONENT LOCATION

		Page- Figure
Air Charge Temperature Sensor .....	4.9L Front lower intake manifold runner .....	122-2
	5.0L Front lower intake manifold runner .....	29-4
	5.8L Front lower intake manifold runner .....	
	7.5L Front lower intake manifold runner .....	
Canister Purge Solenoid .....	5.0L, 5.8L, 7.5L RH side of engine .....	
EEC Clutch Switch .....	Above clutch pedal .....	
EEC Power Relay .....	Under plastic shield at the air cleaner support bracket .....	
EGR Vacuum Regulator Solenoid .....	4.9L at rear of engine on rocker cover bracket .....	121-1
	5.0L on bracket behind ignition coil .....	29-3
	5.8L on bracket behind ignition coil .....	
	7.5L on bracket behind ignition coil .....	
EGR Valve Position Sensor .....	At EGR valve on intake manifold .....	29-3,121-1
Electronic Engine Control (EEC) Module .....	Behind LH kick panel .....	
Engine Coolant Temperature Sensor .....	4.9L at thermostat housing .....	122-2
	5.0L at intake manifold .....	29-4
	5.8L at intake manifold .....	
	7.5L at intake manifold .....	
Fuel Pump Relay .....	Under plastic shield at the air cleaner support bracket .....	
Fuse Link E .....	At C175 LH engine compartment .....	
Fuse Link N .....	Near starter relay .....	
Fuse Link X .....	At C175 LH engine compartment .....	
Fuse Link Z .....	At EEC power relay .....	
Heated Exhaust Gas Oxygen Sensor .....	In communicator tube connecting both exhaust pipes .....	29-3,141-2
Knock Sensor .....	4.9L in cylinder block forward of the distributor .....	121-1
	5.0L in cylinder block behind the intake manifold .....	

*(Continued on next page)*

The **EGR Valve Position (EVP) Sensor** signals the **EEC Module** with the position of the **EGR valve pintle** position.

The **Air Charge Temperature (ACT) Sensor** signals the **EEC Module** with the temperature of the air in the intake manifold.

The **Knock Sensor** signals the **EEC Module** to retard timing if the engine starts to detonate (4.9L and 5.0L only).

An **A/C Clutch Compressor (ACC) Signal** is used to indicate to the **EEC Module** when the A/C compressor is turned On. This will allow the **EEC Module** to increase the engine idle speed and/or compensate for the increased load.

The **Vehicle Speed Sensor** provides a frequency to the **EEC Module** to indicate vehicle speed. The **EEC Module** uses this input for idle speed control and decel fuel shutoff (4.9L, 5.0L, and 5.8L only).

The A/C demand (**ACD**) signal is used to indicate to the **EEC Module** when the climate control switch is in any mode requesting A/C. This will allow the **EEC Module** to increase the engine idle speed (4.9L only).

**Fuel flow** is controlled by **fuel injector solenoids** (six in 6 Cyl. engine, eight in 8 Cyl. engine). The **EEC Module** regulates the amount of fuel injected into each cylinder by the on/off time of the injectors. The longer the on-time, the greater the fuel flow through the injectors. The **EEC Module** uses information received from the system input sensors to determine injector on/off-time.

Fuel pressure is built up by the Electric Fuel Pumps when the **EEC Module** supplies a ground through circuit 97 to the **Fuel Pump Relay**. With the **Ignition Switch** in START or RUN, the **EEC Power Relay** supplies voltage through circuit 361 R, to the **Fuel Pump Relay**. This voltage energizes the **Fuel Pump Relay**.

## COMPONENT LOCATION

	Page-Figure
Manifold Absolute Pressure Sensor .....	On bracket above heater or A/C evaporator housing .....
Power Steering Pressure Switch .....	In power steering pressure hose near the steering gear .....
Thermactor Air Bypass Solenoid .....	4.9L at left rear of engine on rocker cover bracket ..... 121-1 5.0L on bracket behind ignition coil ..... 29-4 5.8L on bracket behind ignition coil ..... 7.5L on bracket behind ignition coil .....
Thermactor Air Diverter Solenoid .....	4.9L at left rear of engine on rocker cover bracket ..... 121-1 5.0L on bracket behind ignition coil ..... 29-4 5.8L on bracket behind ignition coil ..... 7.5L on bracket behind ignition coil .....
Throttle Air Bypass Valve Solenoid .....	On throttle body ..... 29-4, 121-1
Throttle Position Sensor ..	Connected to throttle body shaft ..... 29-4, 121-1

Refer to the **Location Index** in the back of the manual for connector, ground, and splice descriptions and locations.

## TROUBLESHOOTING HINTS

CONDITION	POSSIBLE CAUSE	ACTION
• Intermittent Trouble Codes	• Loose EEC connector	• Clean/Tighten and check wiring

NOTE: The EEC-IV system retains any intermittent trouble codes stored within the last 40 engine starts. With this system, the memory is not erased when the key is turned to Off. However, memory will be lost if the Battery is disconnected.

With power applied through the **EEC Power Relay** to the **Fuel Pump Relay**, and with the **Inertia Switch** closed, power is applied to the **Fuel Pumps**.

Current to the **In-Tank Fuel Pump** passes through a resistance wire and this pump, mounted in the fuel tank, pumps fuel at low (5 psi) pressure. Pressure is boosted by the **In-Line Fuel Pump**.

The efficiency of the catalytic converter is dependent upon the temperature and chemical make-up of exhaust gases. A **Thermactor** air system is used to supply secondary air to the exhaust manifold(s), to the catalyst or to the atmosphere, depending on engine conditions sensed by the **EEC Module** through the system inputs.

When the **Thermactor Air Bypass Solenoid** is OFF (de-energized), Thermactor air is dumped to the atmosphere rather than routed to the catalytic converter or exhaust manifold.

With the **Thermactor Air Bypass Solenoid** ON (energized) and the **Thermactor Air Diverter Solenoid** OFF (de-energized) Thermactor air is downstream (to the catalytic converter).

When the **Thermactor Air Bypass Solenoid** and the **Thermactor Air Diverter Solenoid** are ON (energized), Thermactor air is diverted to the exhaust manifold (upstream).

The **Throttle Air Bypass Valve Solenoid** is an electro-mechanical device controlled by the **EEC Module**. It incorporates a solenoid which positions a variable-area metering valve. This valve is used to control both warm and cold engine airflow into the intake manifold. This allows the **EEC Module** to control the engine warm and cold speed, and allow for "no-touch" starting.

The **EGR Vacuum Regulator Solenoid** controls EGR valve movement. The **EEC Module** receives data from various sensors. It also checks existing valve position through the **EGR Valve Position Sensor** and calculates if the present EGR

flow should be increased, maintained or decreased. The **EEC Module** then determines a proper duty cycle for the **EGR Vacuum Regulator Solenoid** on time to control the EGR valve position.

The **Thick Film Integrated IV (TFI-IV) Ignition Module** supplies the spark signal to the distributor through the ignition coil, and calculates the duration. It receives its control signal from the **EEC Module** through the spark output circuit (324 Y/LG).

Refer to the **Engine/Emissions Diagnosis Manual, volume H, and Technical Service Bulletins** for complete EEC-IV test procedures using special Rotunda test equipment.

# 46 FUEL INJECTOR COOLING FAN (4.9L ENGINE)

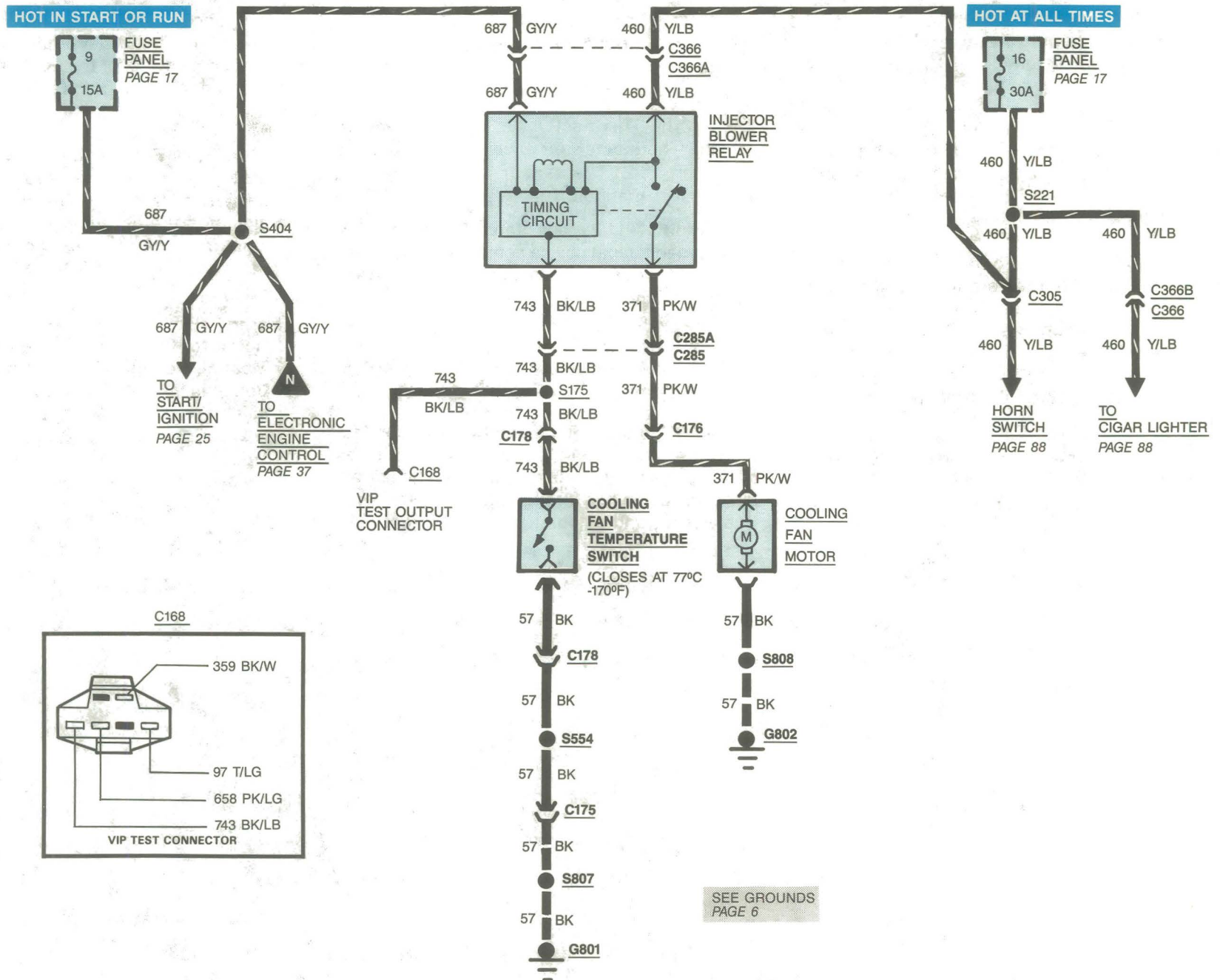

## HOW THE CIRCUIT WORKS

The **Injector Blower Motor** will operate for a maximum of 15 minutes with the **Ignition Switch** in OFF and the **Cooling Fan Temperature Switch** closed. The **Injector Blower Relay** will disable the **Cooling Fan Motor** if the **Cooling Fan Temperature Switch** opens before 15 minutes or if the **Ignition Switch** is turned to RUN. Proper operation of the **Cooling Fan Motor** system can be established by grounding circuit 743 BK/LB at the **VIP** connector (the **Ignition Switch** must be in OFF) and timing the fan ON time. The maximum ON time is 15 minutes.

Refer to section 28-01 of the shop manual.

## COMPONENT LOCATION

Page-  
Figure

Cooling Fan Motor .....	RH inner fender .....	
Injector Blower Relay .....	Behind I/P near fuse panel .....	
Cooling Fan Temperature Switch .....	Clipped to fuel rail near number one fuel injector .....	122-2

Refer to the **Location Index** in the back of the manual for connector, ground, and splice descriptions and locations.

## TROUBLESHOOTING HINTS

CONDITION	POSSIBLE CAUSE	ACTION
<ul style="list-style-type: none"> <li>• Cooling Fan doesn't operate</li> </ul>	<ul style="list-style-type: none"> <li>• No voltage at Y/LB wire of Injector Blower Relay</li> <li>• No or poor continuity of BK wire from Cooling Fan Motor to G802</li> <li>• No voltage at Cooling Fan Motor</li> <li>• Inoperative Cooling Fan Motor</li> <li>• Inoperative Cooling Fan Temperature Switch</li> </ul>	<ul style="list-style-type: none"> <li>• Check wiring and Fuse 16</li> <li>• Check for loose connection at ground and open in BK wire</li> <li>• Check for open in PK/W wire between Injector Blower Relay and Cooling Fan Motor.</li> <li>• Apply voltage and ground to motor. If motor does not operate, replace with known good motor.</li> <li>• Bypass switch by shorting across connector terminals. If motor operates, replace switch.</li> </ul>

# 48 HEADLAMPS

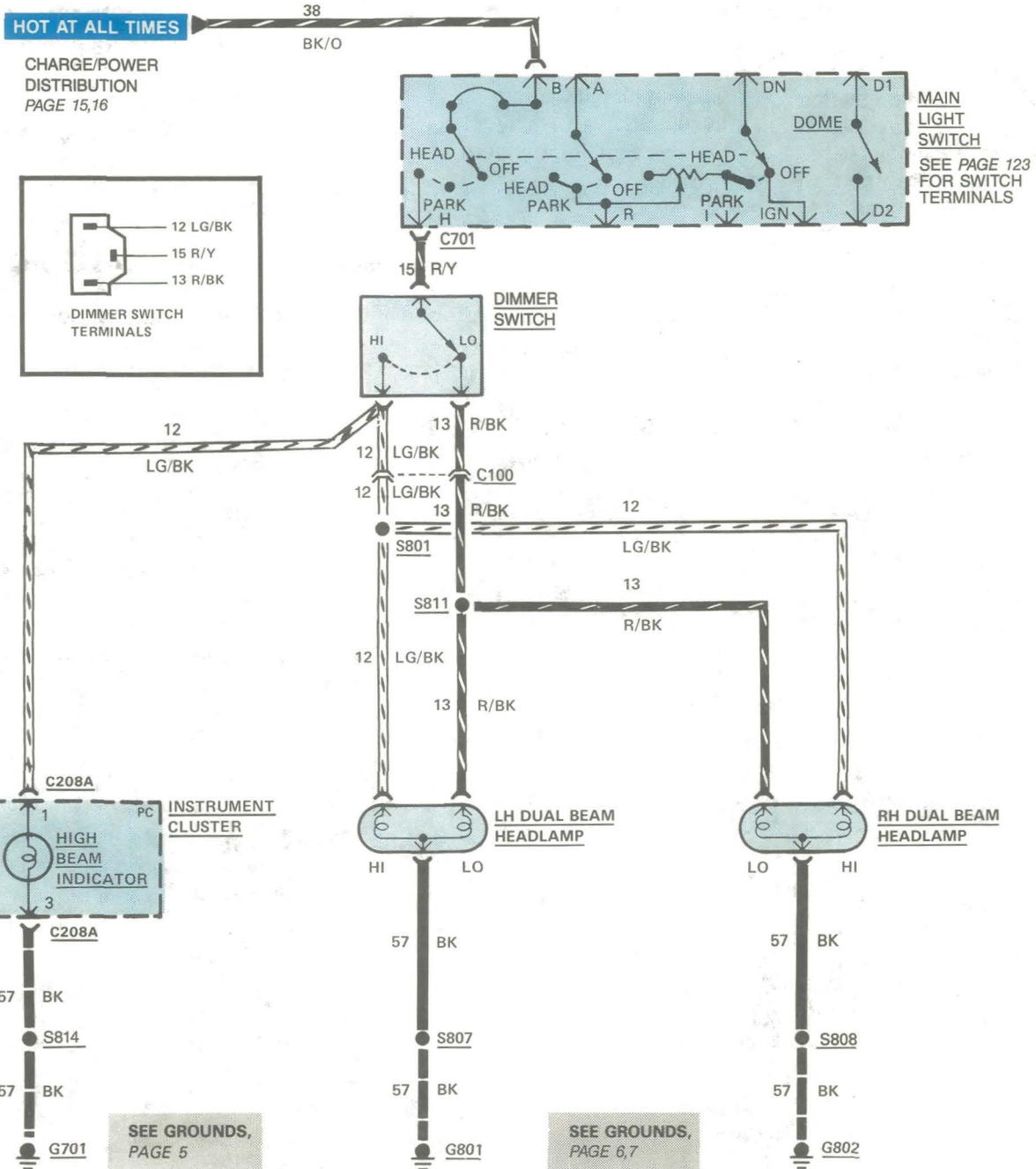

## HOW THE CIRCUIT WORKS

Battery voltage is applied at all times through **Fuse Link J** to the **Main Light Switch**. When the **Main Light Switch** is pulled to HEAD, voltage is applied through the **Light Switch** and the **Dimmer Switch** to the **Headlamps**. The **Headlamps** will operate in either HI or LO Beam depending upon the position of the **Dimmer Switch**. The **Headlamps** are permanently grounded through **G801** and **G802**.

When the **Dimmer Switch** is in HI, voltage is also applied to the **High Beam Indicator**. The Indicator is permanently grounded through **G701**.

Refer to section 32-01 of the shop manual.

## COMPONENT LOCATION

Page-  
Figure

Main Light Switch .....	LH side of I/P .....	95-2
Dimmer Switch .....	On floor pan LH side of cab .....	

Refer to the **Location Index** in the back of the manual for connector, ground, and splice descriptions and locations.

## TROUBLESHOOTING HINTS

CONDITION	POSSIBLE CAUSE	ACTION
<ul style="list-style-type: none"> <li>• No headlamps, but park lamps function</li> </ul>	<ul style="list-style-type: none"> <li>• No voltage at R/Y wire of Dimmer Switch</li> <li>• No voltage at R/BK wire of Dimmer Switch</li> </ul>	<ul style="list-style-type: none"> <li>• Check continuity of wire and Light Switch/replace or repair</li> <li>• Repair/Replace Switch</li> </ul>
<ul style="list-style-type: none"> <li>• No HI or LO Beam on one side</li> </ul>	<ul style="list-style-type: none"> <li>• Poor ground connection on affected side</li> </ul>	<ul style="list-style-type: none"> <li>• Clean/Tighten</li> </ul>

# 50 EXTERIOR LAMPS (PARK, MARKER)

HOT AT ALL TIMES



195 T/W C701

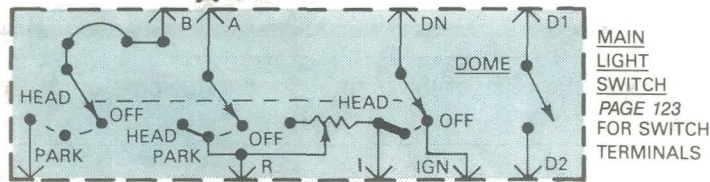

BRONCO

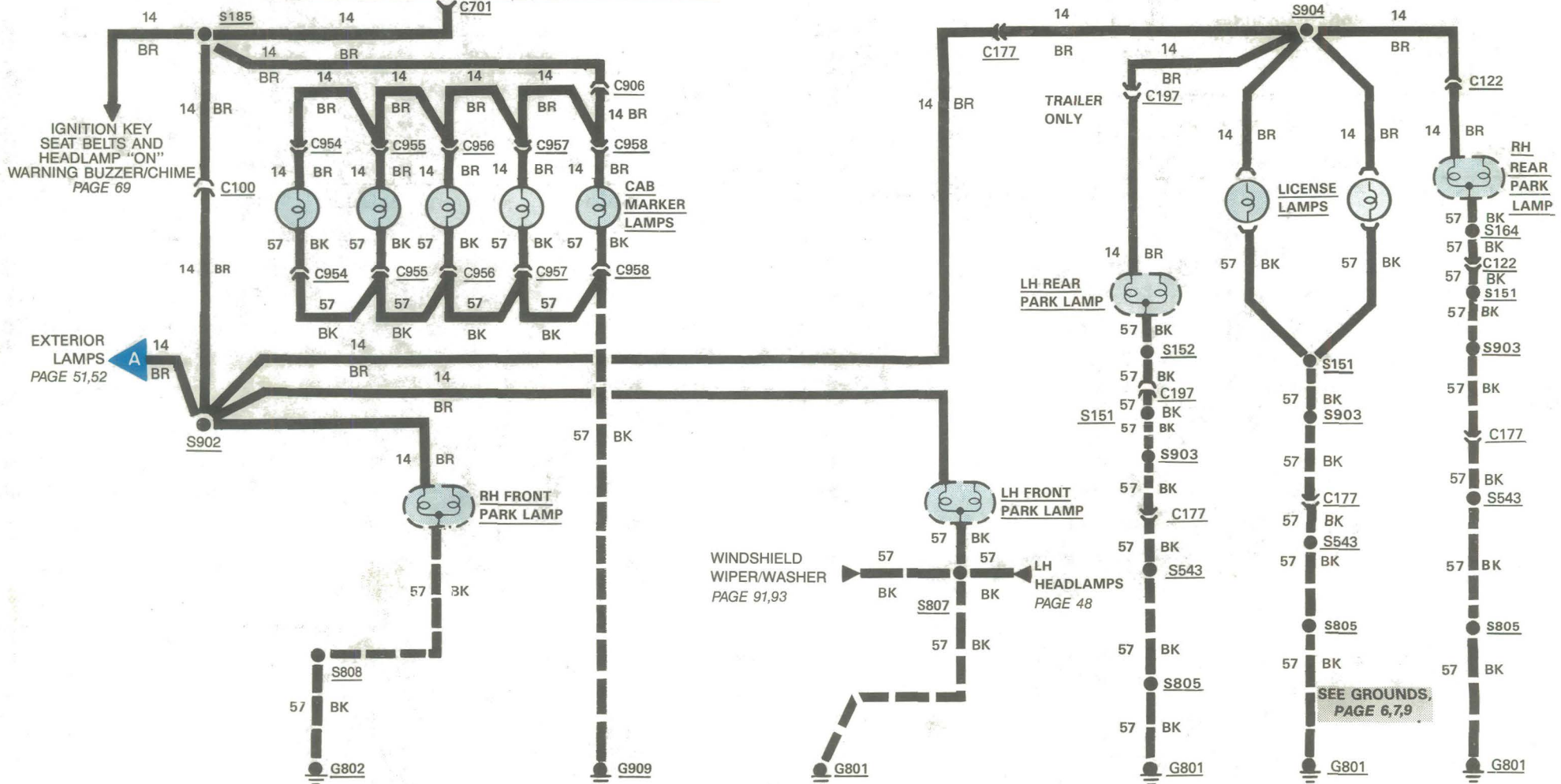

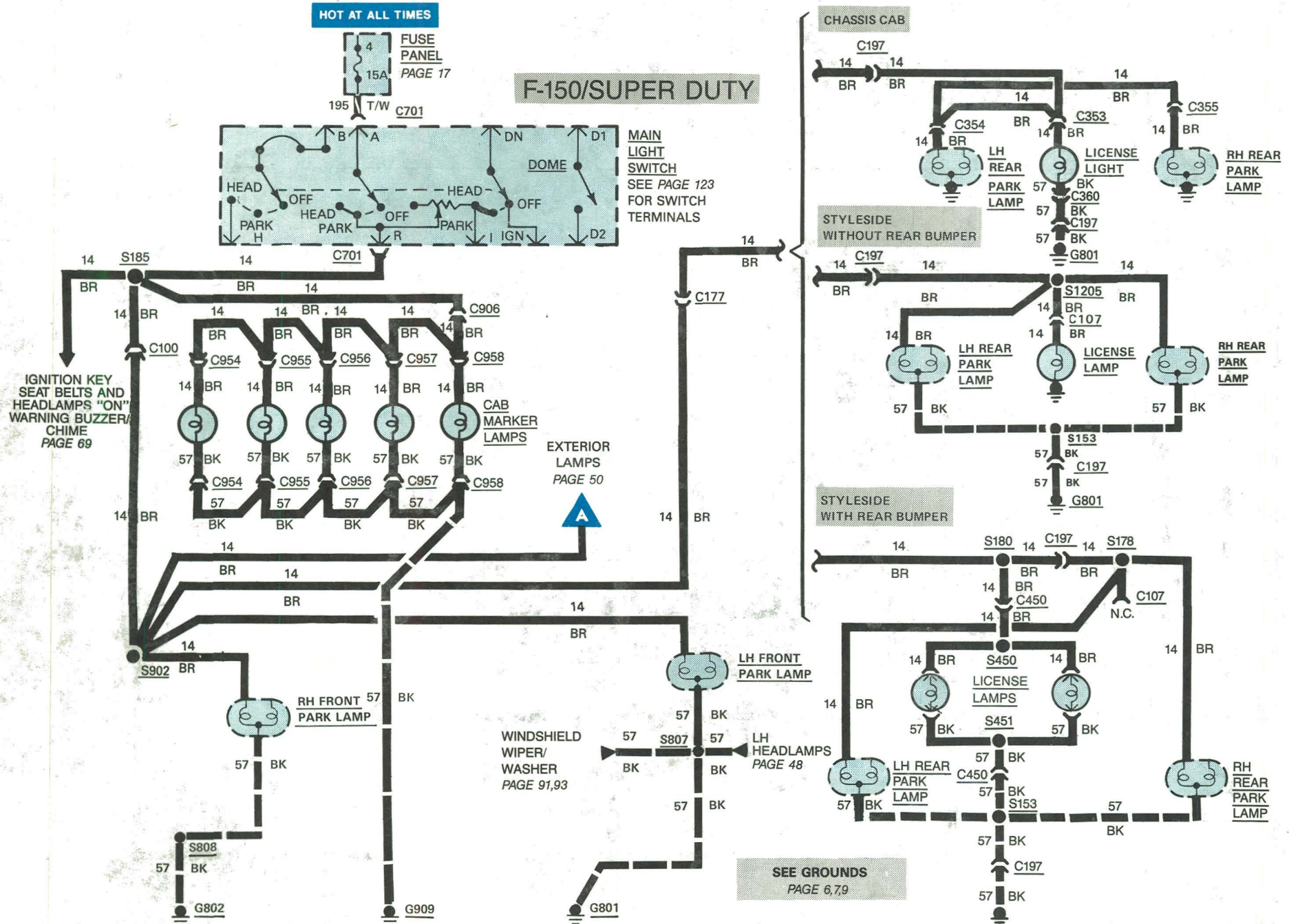



## HOW THE CIRCUIT WORKS

When the **Main Light Switch** is turned to PARK or HEAD, battery voltage is applied through **Fuse 4** to the **Park, Marker, and License Lamps**. All of these lamps are permanently grounded and light whenever voltage is applied.

Refer to section 32-01 of the shop manual.

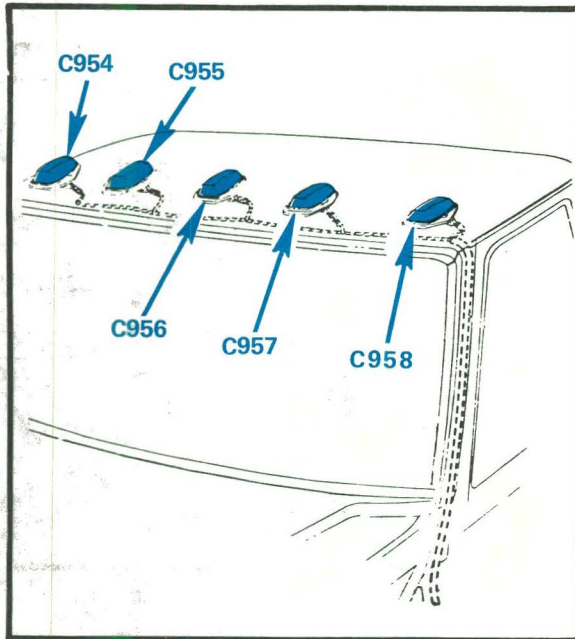

Figure 1 - Top Of Cab

## COMPONENT LOCATION

Page-  
Figure

Fuse Link G .....	Near starter relay .....
Fuse Link H .....	Near marker lamps relay .....
Fuse Link P .....	Near trailer lamps relay .....
Marker Lamp Relay .....	Attached to dash panel .....
Trailer Lamp Relay .....	Attached to dash panel .....

Refer to the **Location Index** in the back of the manual for connector, ground, and splice descriptions and locations.

## TROUBLESHOOTING HINTS

CONDITION	POSSIBLE CAUSE	ACTION
<ul style="list-style-type: none"> <li>No exterior lamps light</li> </ul>	<ul style="list-style-type: none"> <li>No voltage at T/W wire of Main Light Switch</li> <li>C701 is loose</li> <li>No voltage at BR wire of lamps</li> <li>Defective Main Light Switch</li> </ul>	<ul style="list-style-type: none"> <li>Check Fuse 4 and wiring</li> <li>Tighten/Replace</li> <li>Check for open in BR wire</li> <li>Replace Switch as required</li> </ul>
<ul style="list-style-type: none"> <li>One lamp does not light</li> </ul>	<ul style="list-style-type: none"> <li>Blown bulb</li> <li>Frayed or damaged wires or loose wires</li> </ul>	<ul style="list-style-type: none"> <li>Replace bulb as required</li> <li>Repair as required</li> </ul>

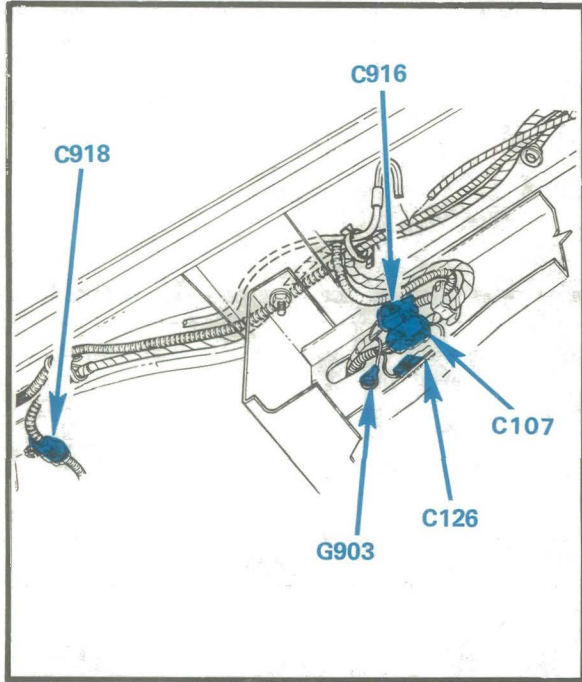

Figure 2 LH Side Of Rear Crossmember

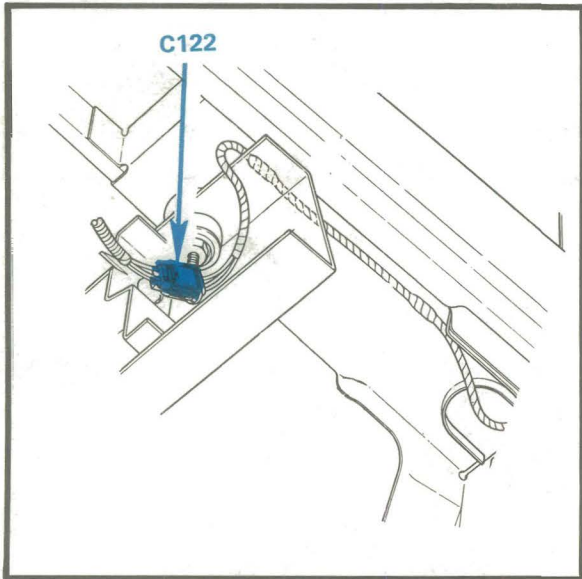

Figure 3 - RH Side Of Rear Crossmember

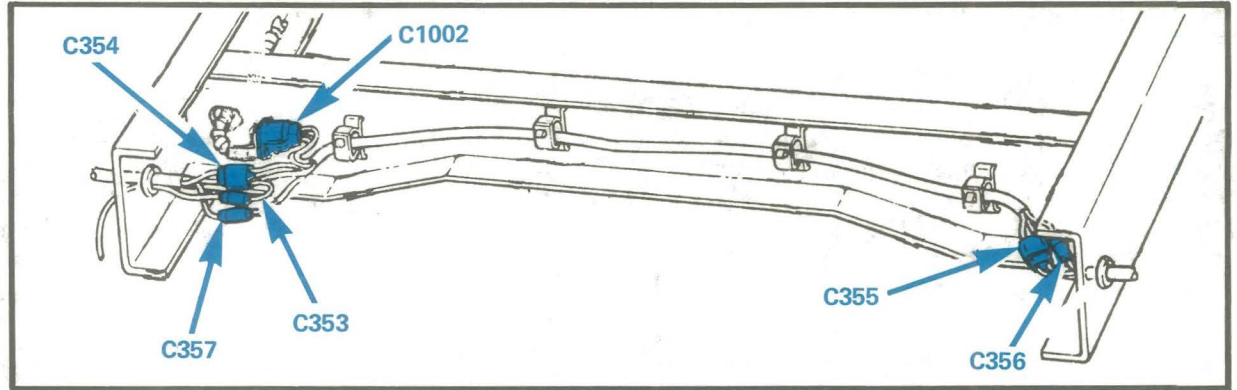

Figure 4 - Rear Frame Crossmember

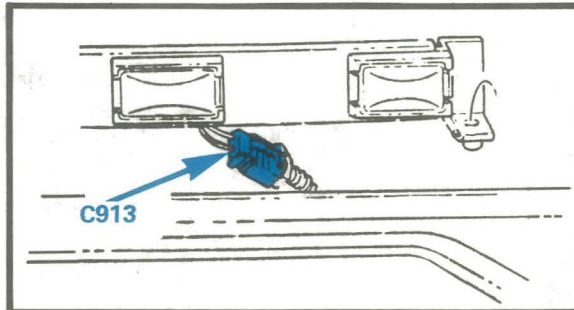

Figure 5 - Center Of Rear Bumper

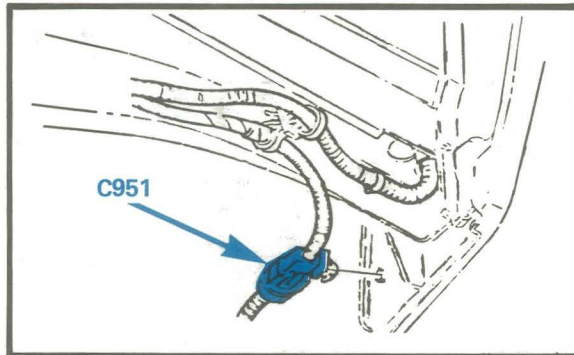

Figure 6 - RH Side Of Rear Crossmember

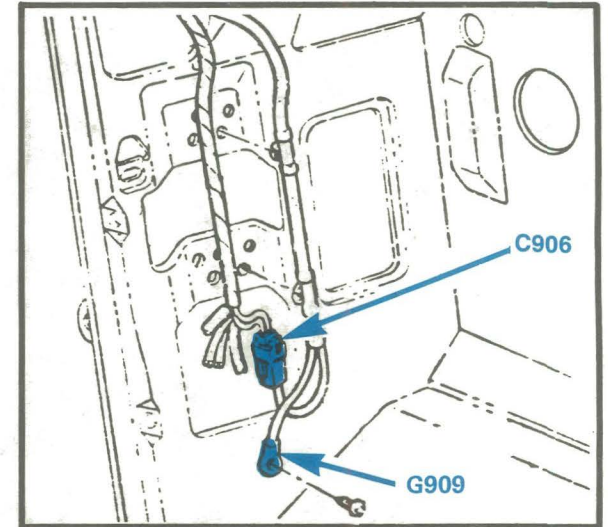

Figure 7 - Lower LH Cowl Area

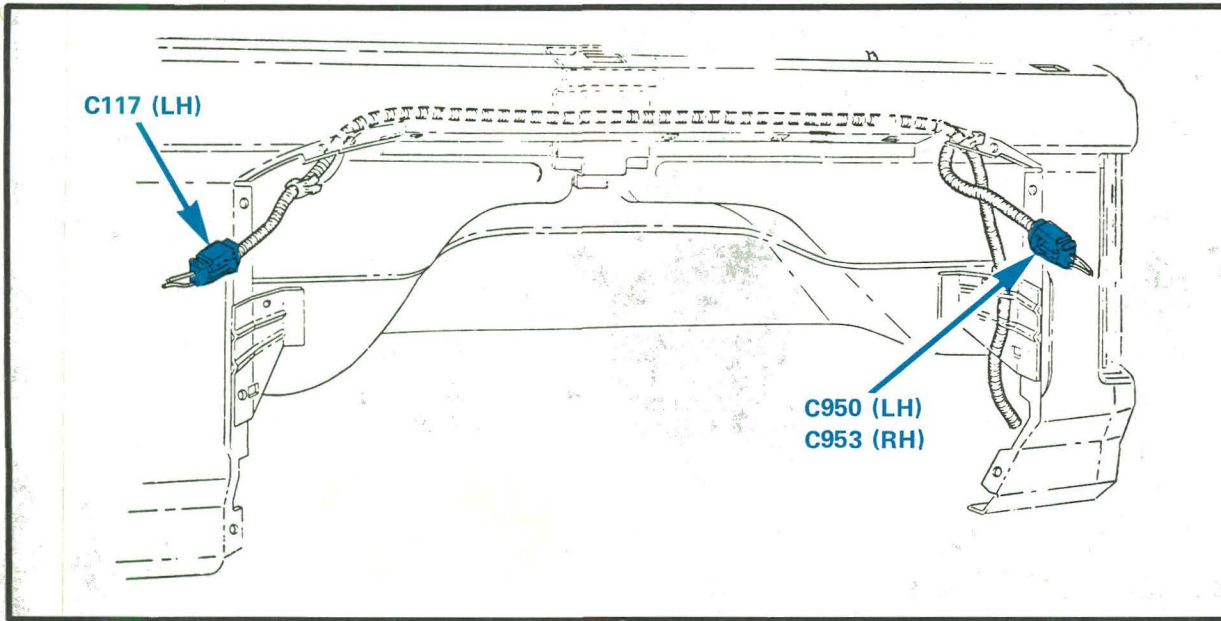

Figure 8—LH Rear Fender Well for Dual Wheels (RH Similar)

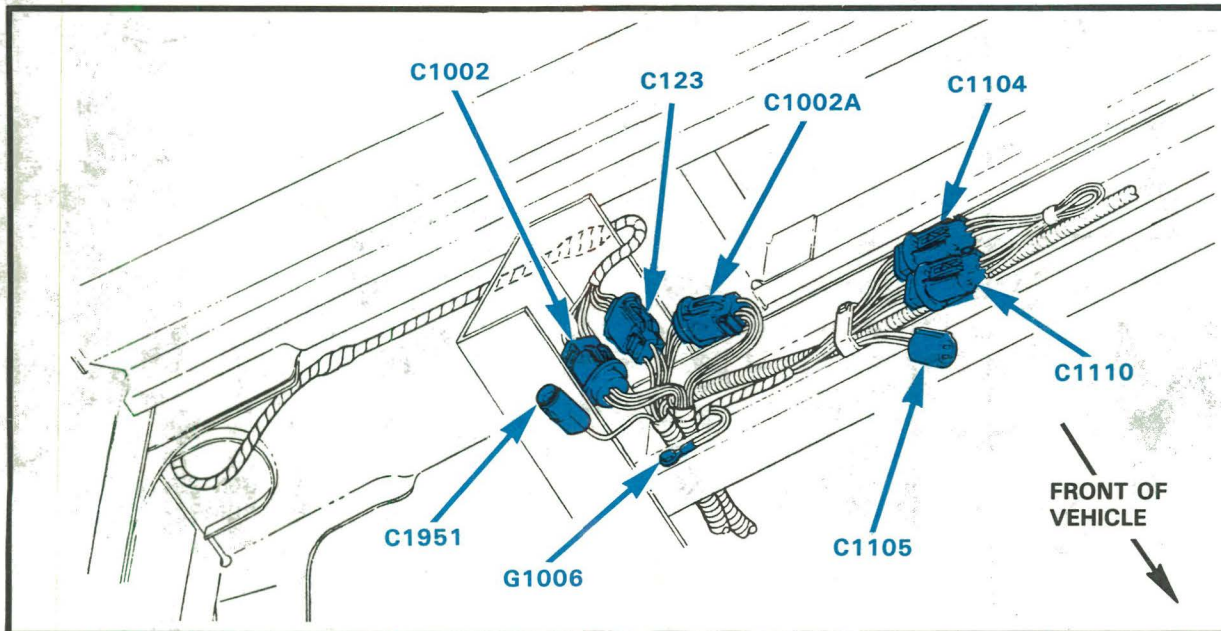

Figure 9—Rear LH Side Frame Crossmember

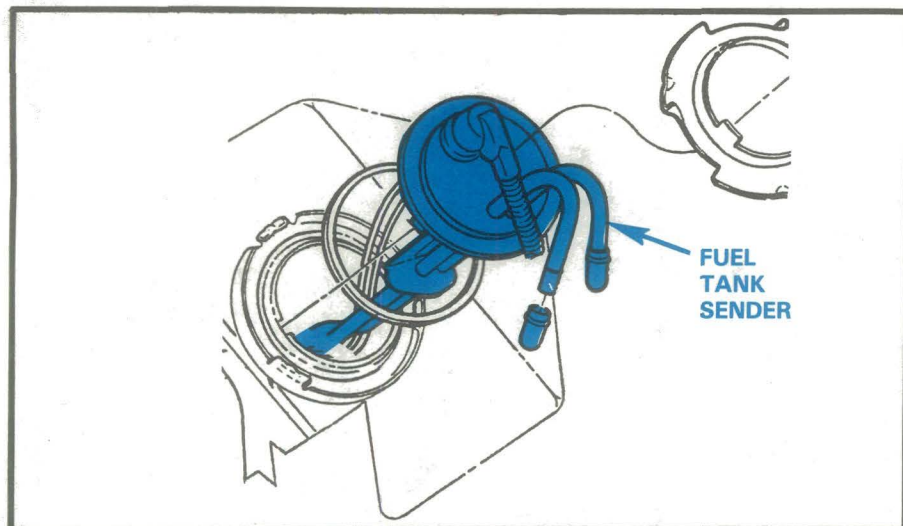

Figure 10 — Rear Tank (Behind Rear Axle)  
(Bronco Only)

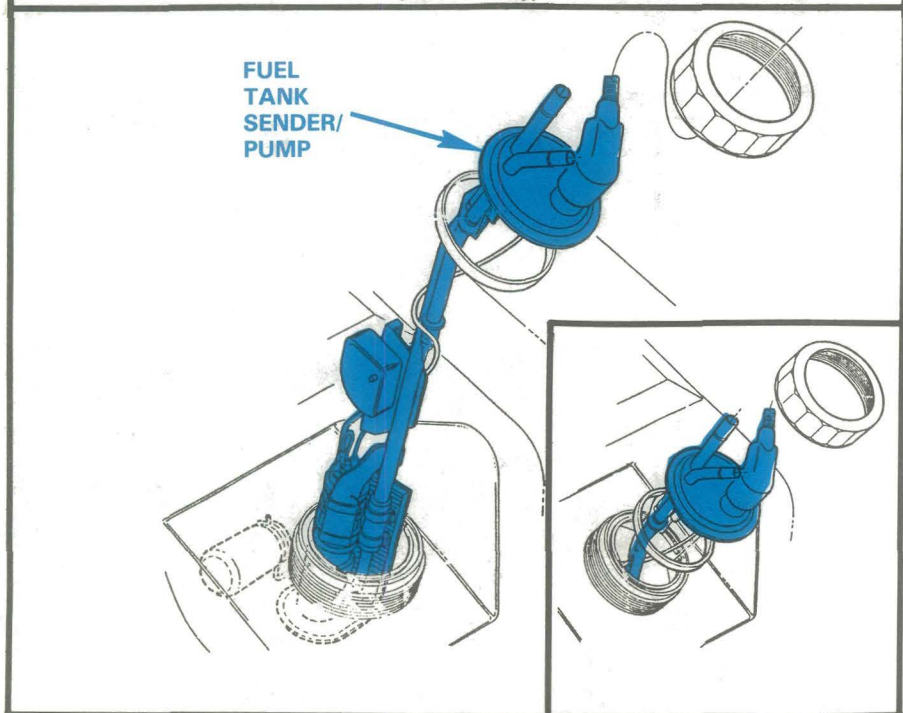
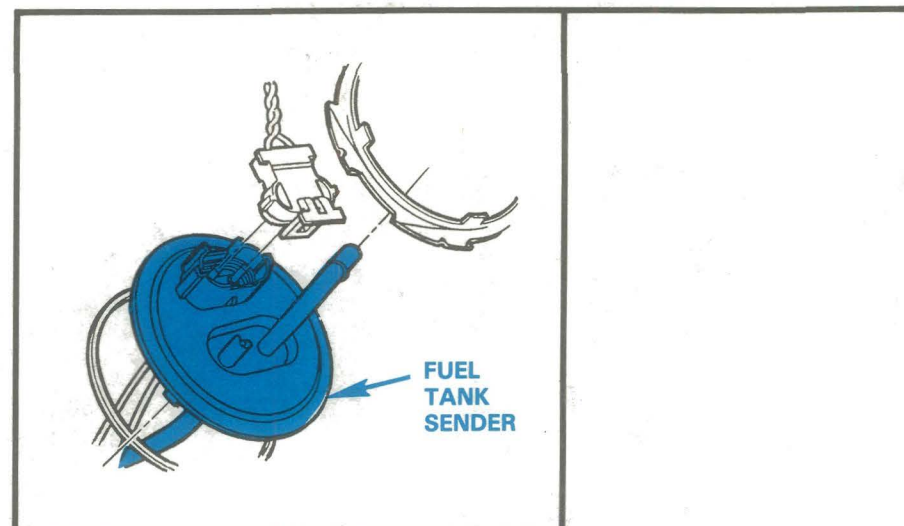

Figure 11 — Plastic Fuel Tank  
(F-Series)

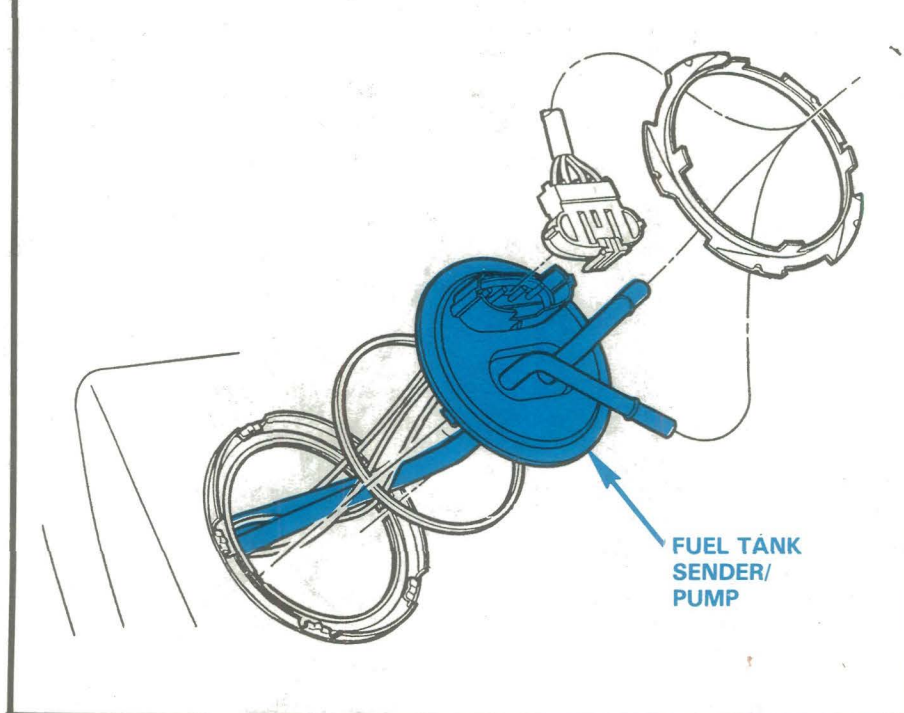
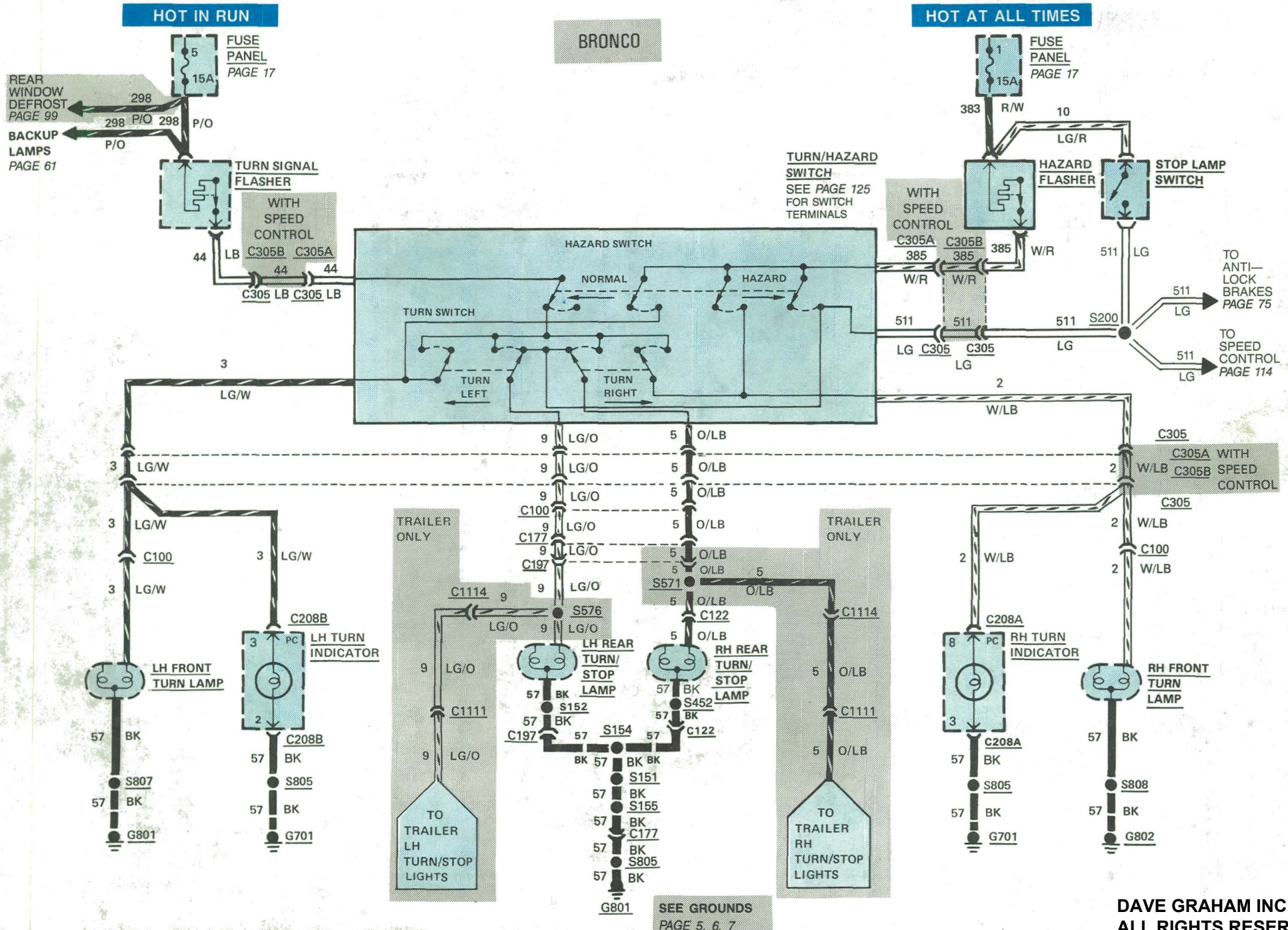
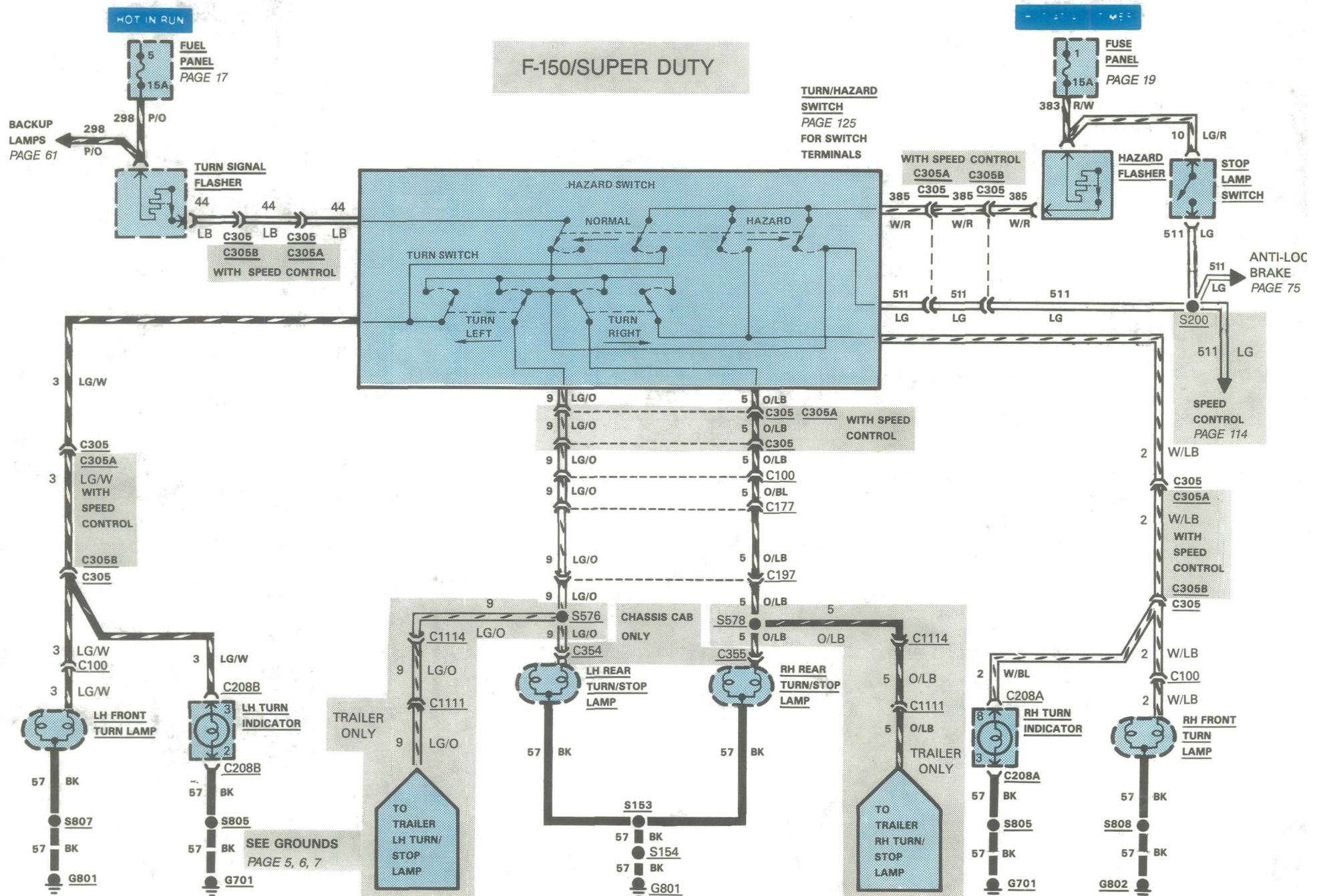

Figure 12 — Metal Fuel Tank  
(F-Series)



# 58 TURN/STOP/HAZARD LAMPS



## HOW THE CIRCUIT WORKS

### Turn Signals and Hazard Flashers

With the Ignition Switch in RUN, voltage is applied through Fuse 5 and the Turn Signal Flasher to the Turn/Hazard Switch. When the Turn/Hazard Switch is closed for LH, RH, or Hazard Indicator operation, voltage is applied through the Switch to the lamps. All of these lamps are permanently grounded.

### Stop Lights

Voltage is applied through Fuse 1 to the Stop Lamp Switch. When the Brake Pedal is pressed, the Stop Lamp Switch closes, and voltage is applied through the closed contacts of the Turn/Hazard Switch to the Stop Lamps. These lamps are permanently grounded.

Refer to section 32-01 of the shop manual.

## COMPONENT LOCATION

Page-  
Figure

Hazard Flasher .....	In rear of fuse panel .....	
Stop Lamp Switch .....	Mounted to bracket at top of brake pedal .....	74-2
Turn Signal Flasher .....	In front of fuse panel .....	14-1
Turn/Hazard Switch .....	Mounted in steering column .....	

Refer to the **Location Index** in the back of the manual for connector, ground, and splice descriptions and locations.

## TROUBLESHOOTING HINTS

CONDITION	POSSIBLE CAUSE	ACTION
<ul style="list-style-type: none"> <li>Hazard Flashers do not work</li> </ul>	<ul style="list-style-type: none"> <li>No voltage at R/W Hazard Flasher wire</li> <li>Defective Hazard Flasher</li> <li>No voltage at C305 W/R wire</li> <li>Defective Turn/Hazard Switch</li> </ul>	<ul style="list-style-type: none"> <li>Check Fuse 1 and wiring</li> <li>Replace with known good flasher</li> <li>Repair open in wiring</li> <li>Replace with known good switch</li> </ul>
<ul style="list-style-type: none"> <li>No Turn Indicators work</li> </ul>	<ul style="list-style-type: none"> <li>No voltage at P/O wire of Turn Signal Flasher</li> <li>No voltage at C305 LB wire</li> <li>Defective Turn Signal Flasher</li> <li>Defective Turn/Hazard Switch</li> </ul>	<ul style="list-style-type: none"> <li>Check Fuse 5 and wiring</li> <li>Repair open in wiring</li> <li>Replace with known good flasher</li> <li>Replace as required</li> </ul>
<ul style="list-style-type: none"> <li>No Stop Lamps</li> </ul>	<ul style="list-style-type: none"> <li>No voltage at LG/R wire of Stop Lamp Switch</li> <li>Defective Stop Lamp Switch</li> </ul>	<ul style="list-style-type: none"> <li>Check Fuse 1 and wiring</li> <li>Replace with known good switch</li> </ul>

## TROUBLESHOOTING HINTS (CONT'D)

CONDITION	POSSIBLE CAUSE	ACTION
<ul style="list-style-type: none"> <li>One Turn Indicator not working</li> </ul>	<ul style="list-style-type: none"> <li>Blown bulb</li> <li>No voltage at socket</li> <li>Poor ground</li> <li>Defective Turn/Hazard Switch</li> </ul>	<ul style="list-style-type: none"> <li>Replace bulb</li> <li>Repair opens in wiring</li> <li>Clean or repair open in BK ground wire</li> <li>Replace switch as required</li> </ul>

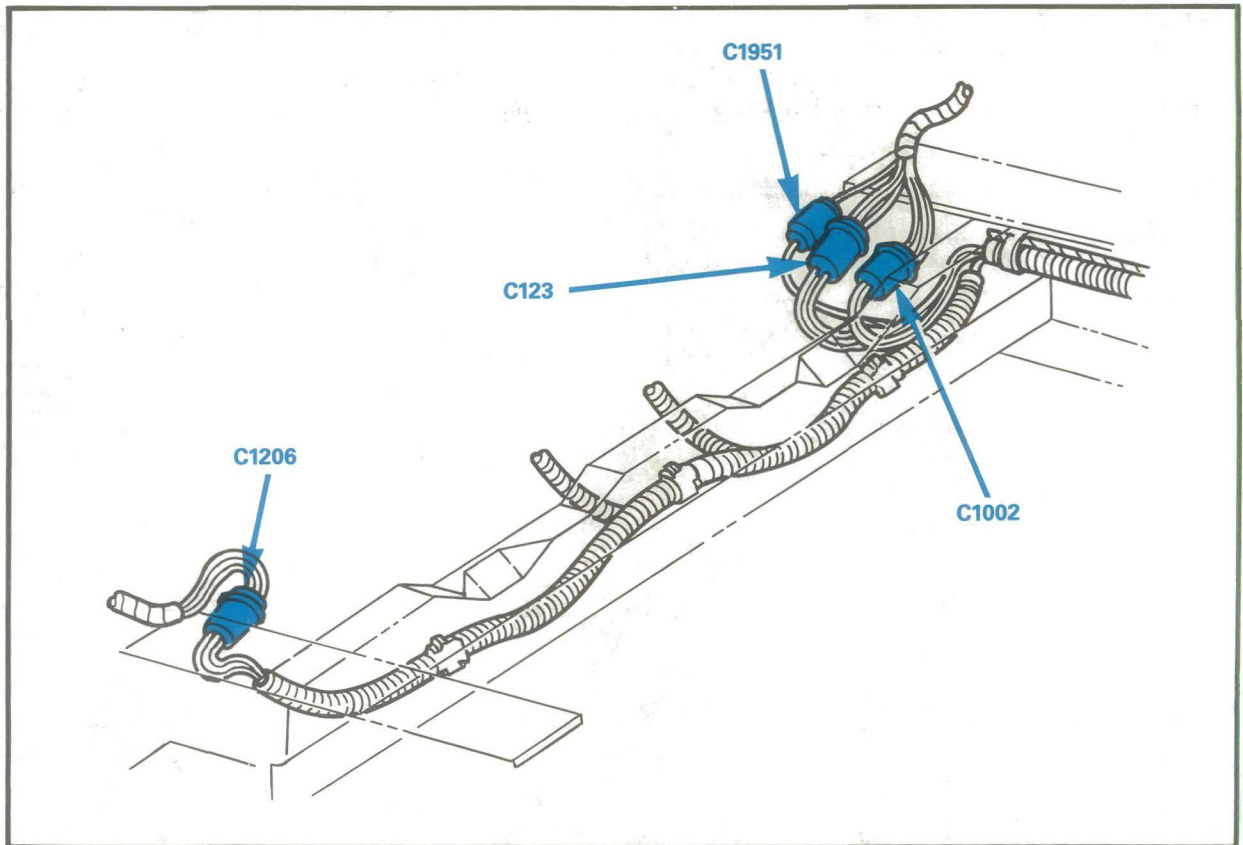
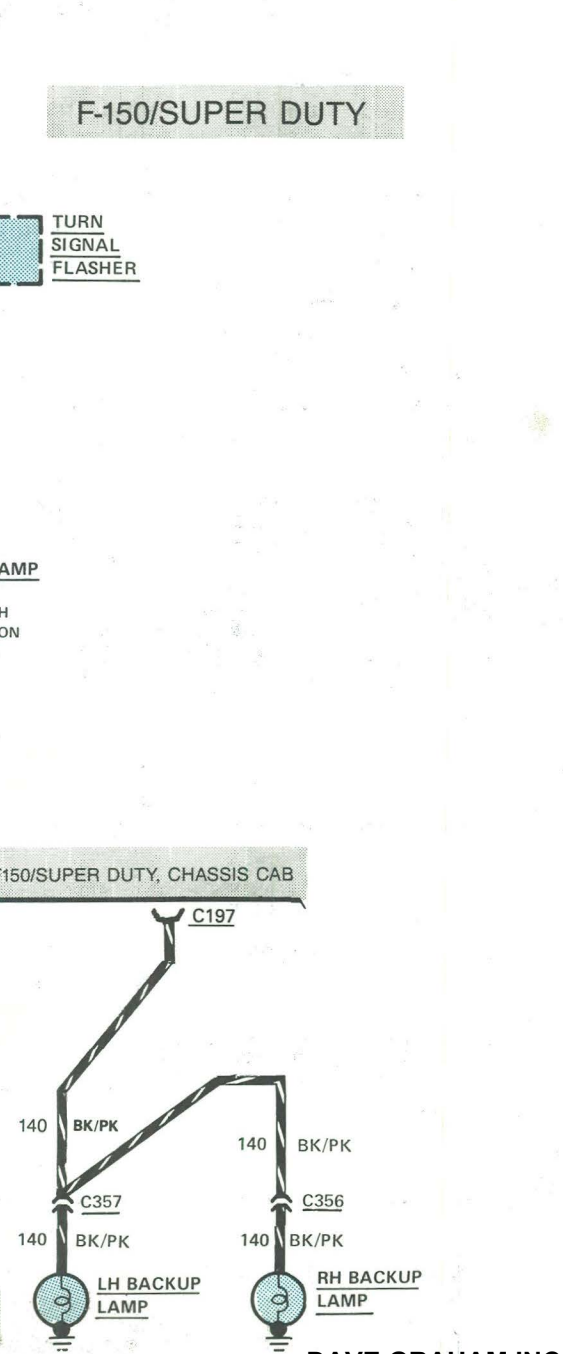
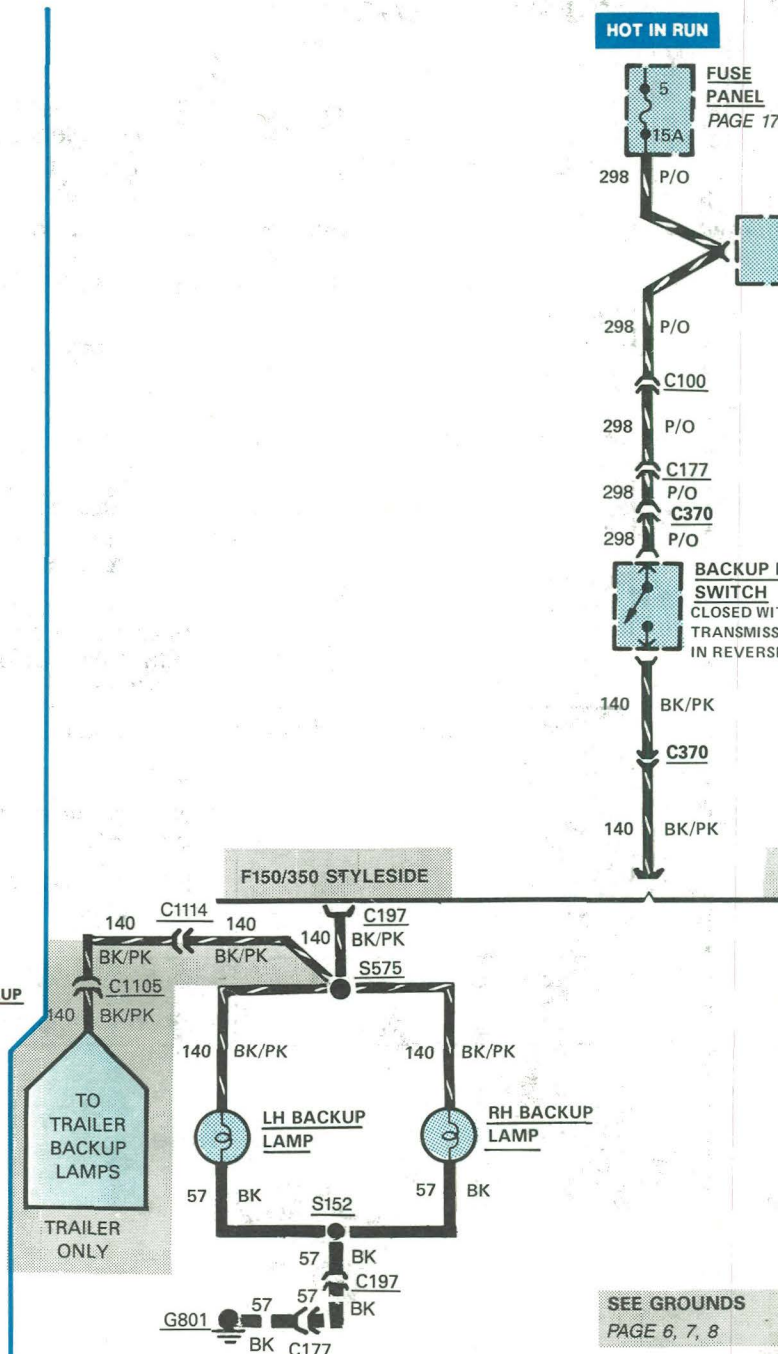
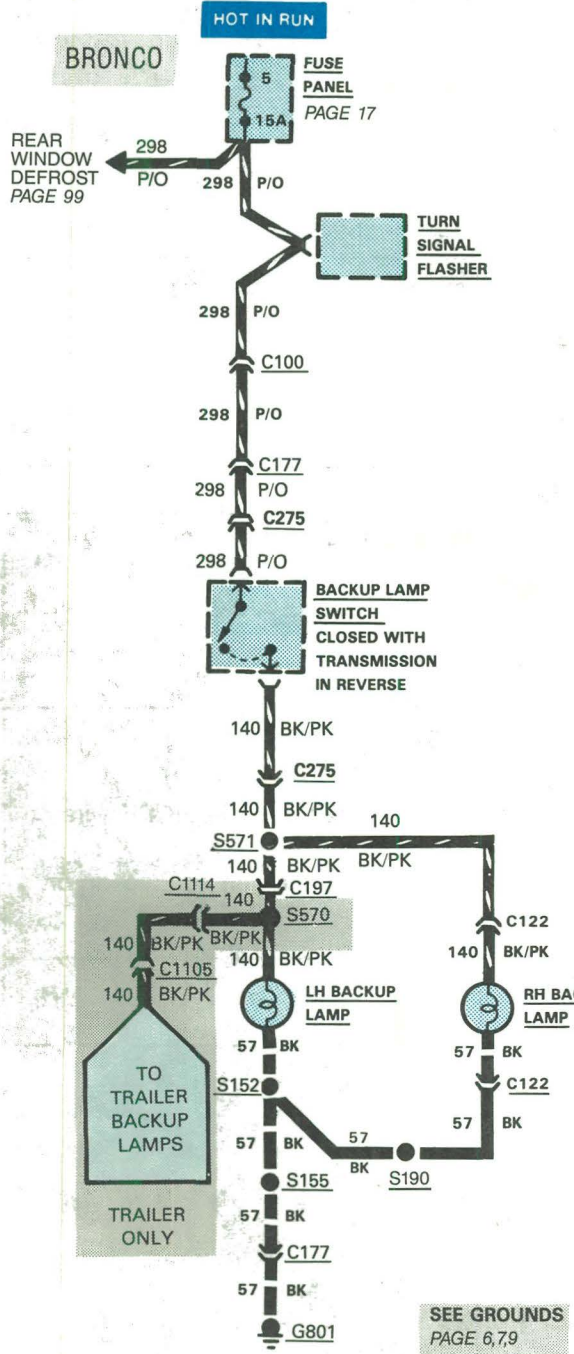

Figure 1 – At Rear Crossmember



# 62 BACKUP LAMPS

## HOW THE CIRCUIT WORKS

With the **Ignition Switch** in RUN or START, battery voltage is applied through **Fuse 5** to the **Backup Lamp Switch**. When the transmission is placed in REVERSE, the **Backup Lamp Switch** closes and voltage is applied to the LH and RH **Backup Lamps**. These lamps are permanently grounded through **G801**.

Refer to section 32-01 of the shop manual.

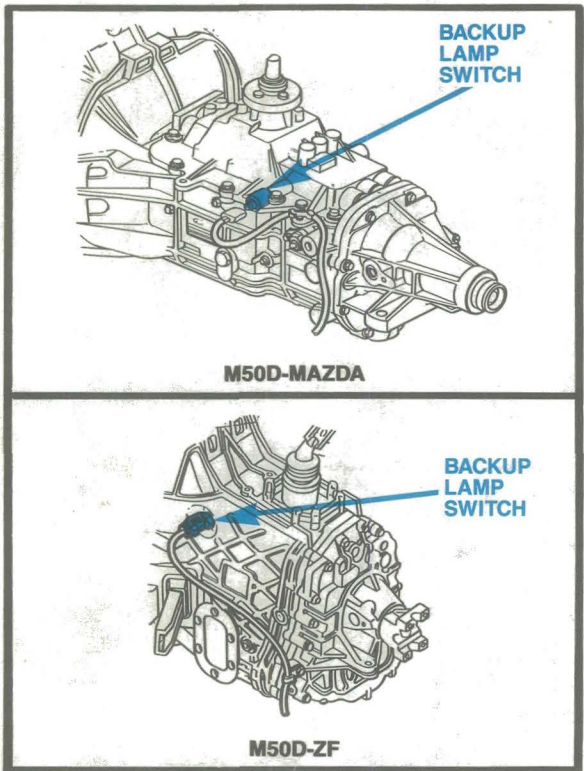

Figure 1 - Manual Transmissions

## COMPONENT LOCATION

Page-  
Figure

Backup Lamp Switch . . . . .	Part of manual transmission assembly or neutral safety switch . . . . .	62-1
Turn Signal Flasher . . . . .	In front of fuse panel . . . . .	14-1

Refer to the **Location Index** in the back of the manual for connector, ground, and splice descriptions and locations.

## TROUBLESHOOTING HINTS

CONDITION	POSSIBLE CAUSE	ACTION
<ul style="list-style-type: none"> <li>No Backup Lamps light</li> </ul>	<ul style="list-style-type: none"> <li>No voltage at P/O wire of Backup Lamp Switch</li> <li>No voltage at BK/PK wire of Backup Lamp Switch with transmission in Reverse.</li> </ul>	<ul style="list-style-type: none"> <li>Check Fuse 5 and wiring for opens</li> <li>Replace Backup Lamp Switch</li> </ul>
<ul style="list-style-type: none"> <li>One Backup Lamp will not light</li> </ul>	<ul style="list-style-type: none"> <li>Blown bulb</li> <li>Check socket for corrosion</li> <li>No voltage at socket hot pin</li> <li>Poor ground connection from bulb</li> </ul>	<ul style="list-style-type: none"> <li>Replace bulb</li> <li>Clean/Replace</li> <li>Repair open in BK/PK wire of socket</li> <li>Clean/Tighten connection or repair open in wiring</li> </ul>
<ul style="list-style-type: none"> <li>Backup Lamps stay on</li> </ul>	<ul style="list-style-type: none"> <li>Defective Switch</li> <li>Short to voltage</li> </ul>	<ul style="list-style-type: none"> <li>Replace as required</li> <li>Repair wiring</li> </ul>





## HOW THE CIRCUIT WORKS

Battery voltage is applied at all times through **Fuse 8** to the various **Courtesy, Dome, and Cargo Lamp Switches**. When the switches are closed, voltage is applied through the switches to the lamps. All of these lamps are permanently grounded.

Refer to section 32-01 of the shop manual.

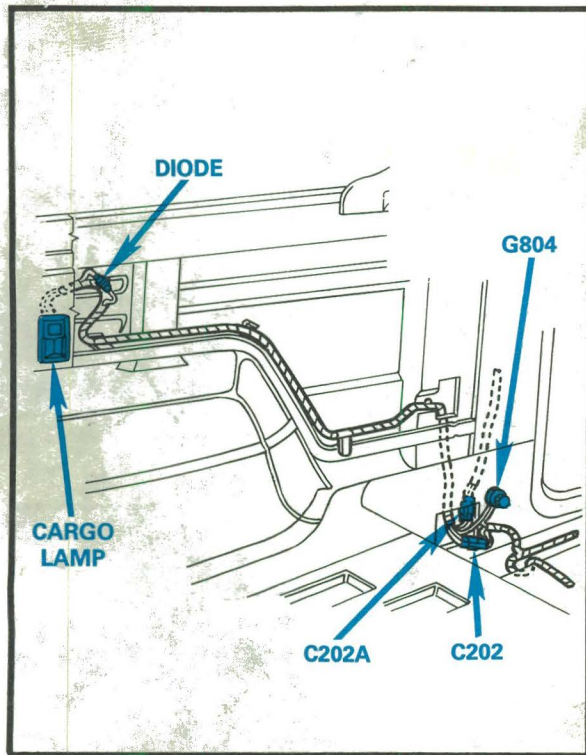

Figure 1 – Cargo Area of Bronco

## COMPONENT LOCATION

Page-  
Figure

Door Jamb Switches . . . . .	LH lower cowl, near fuse panel . . . . .	
In-Line Diode (Bronco) . . . . .	Forward of cargo lamp above LH rear wheelwell . . . . .	65-1
In-Line Diode . . . . .	Above LH quarter window . . . . .	
(F150-F SUPER DUTY)		

Refer to the **Location Index** in the back of the manual for connector, ground, and splice descriptions and locations.

## TROUBLESHOOTING HINTS

CONDITION	POSSIBLE CAUSE	ACTION
<ul style="list-style-type: none"> <li>No lamps light</li> </ul>	<ul style="list-style-type: none"> <li>No voltage at LG/Y wire of switches</li> </ul>	<ul style="list-style-type: none"> <li>Check Fuse 8 and wiring</li> </ul>
<ul style="list-style-type: none"> <li>Single lamp doesn't light</li> </ul>	<ul style="list-style-type: none"> <li>Blown bulb</li> <li>Socket corrosion</li> <li>Defective switch</li> </ul>	<ul style="list-style-type: none"> <li>Replace bulb</li> <li>Clean/Replace</li> <li>Replace switches as required</li> </ul>

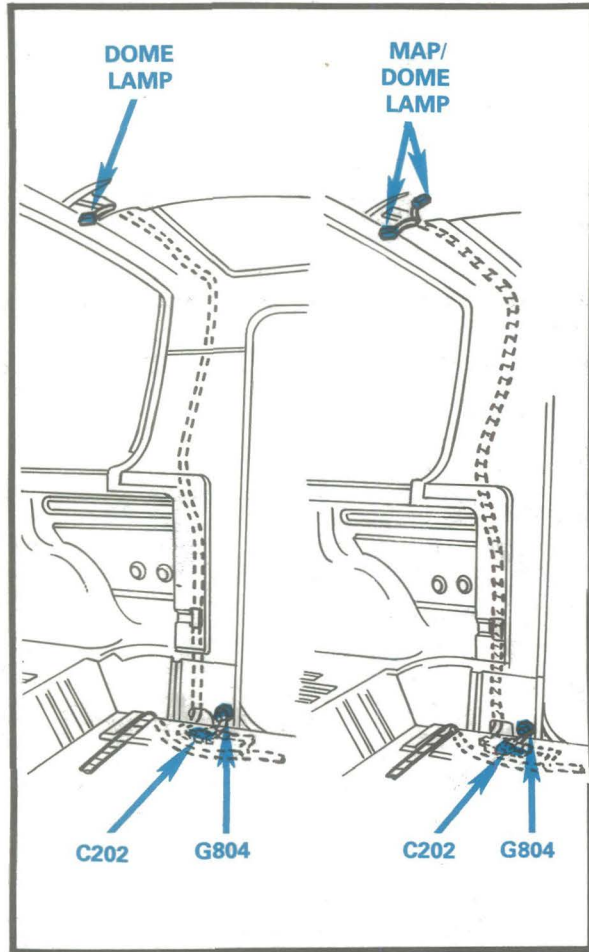

Figure 2 – Dome and Map/Dome Lamp Wiring (Bronco)

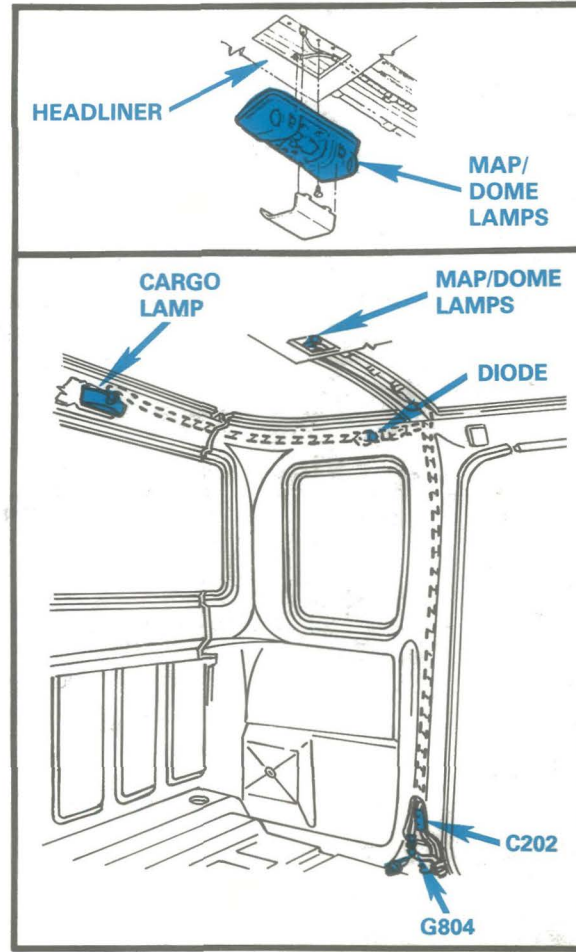

Figure 3 – LH Quarter Panel of Super Cab

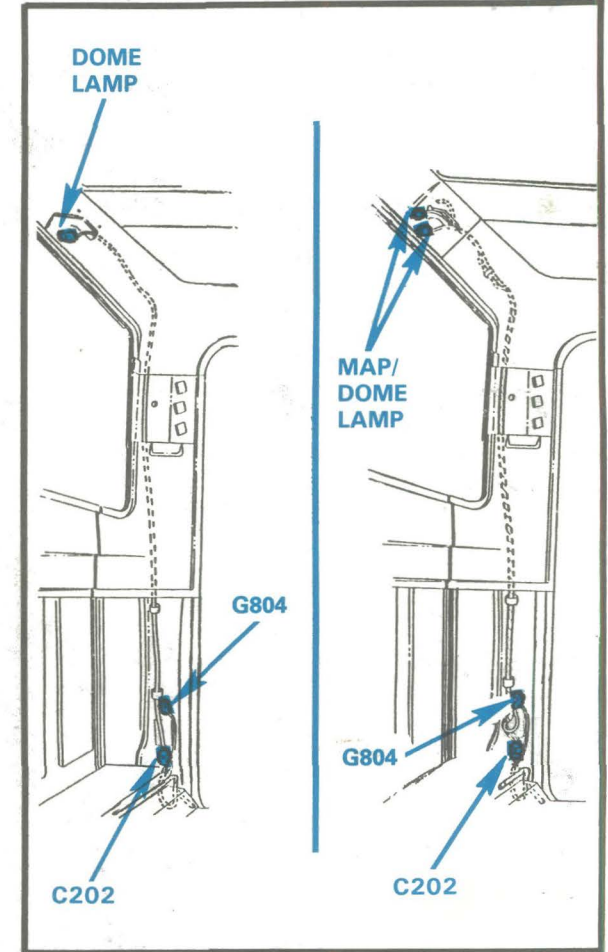

Figure 4 – LH Quarter Panel of Regular Cab



## HOW THE CIRCUIT WORKS

Battery voltage is applied at all times through **Fuse 4** to the **Main Light Switch**. When the **Main Light Switch** is turned to PARK or HEAD, voltage is applied through the switch to the **Instrument Illumination Lamps**. The amount of voltage, and in turn the intensity of the lamps, can be adjusted by rotating the **Dimmer Switch**.

Refer to section 32-01 of the shop manual.

## COMPONENT LOCATION

Main Light Switch . . . . . I/P, left of steering column . . . . . 95-2

Page-  
Figure

Refer to the **Location Index** in the back of the manual for connector, ground, and splice descriptions and locations.

## TROUBLESHOOTING HINTS

CONDITION	POSSIBLE CAUSE	ACTION
<ul style="list-style-type: none"> <li>No Instrument Lamps light</li> </ul>	<ul style="list-style-type: none"> <li>No voltage at T/W wire of Main Light Switch</li> <li>No voltage at LB/R wire of lamps</li> <li>Defective Dimmer Switch</li> <li>No or poor continuity at circuit connections</li> </ul>	<ul style="list-style-type: none"> <li>Check Fuse 4 and wiring</li> <li>Check Fuse 17, wiring, and Main Light Switch</li> <li>Replace with known good Dimmer Switch</li> <li>Clean/Tighten connections</li> </ul>
<ul style="list-style-type: none"> <li>One Lamp does not light</li> </ul>	<ul style="list-style-type: none"> <li>Blown bulb</li> <li>Socket corrosion</li> </ul>	<ul style="list-style-type: none"> <li>Replace bulb as required</li> <li>Clean/Replace socket</li> </ul>



## WARNING INDICATORS

### HOW THE CIRCUIT WORKS

With the **Ignition Switch** in RUN or START, the **Oil Pressure Warning Indicator** comes on if the oil pressure is too low.

The **Brake Warning Indicator** goes on:

1. With the **Ignition Switch** in START, to test the bulb. (This connection is closed just before the **Starter Relay** pulls in.)
2. When the brakes are applied and either front or rear brake system has failed (low pressure).
3. When the **Parking Brake Switch** closes.

With the **Ignition Switch** in START, the **Check Engine Warning Indicator** lights to test the bulb. With the **Ignition Switch** in RUN, the **Check Engine Warning Indicator** lights when a malfunction has occurred in the **EEC** system.

Refer to section 33-01 of the shop manual.

## SEATBELT WARNING

### HOW THE CIRCUIT WORKS

With the **Ignition Switch** in RUN, voltage is applied through **Fuse 18**, and the "**Fasten Belts**" **Indicator** for 4 to 8 seconds, whether belts are buckled or not. The buzzer/chime will sound during this time only if the driver's belt is not buckled.

Refer to section 33-01 of the shop manual.

### COMPONENT LOCATION

Page-Figure

Brake Sensor .....	Part of master cylinder .....
Brake Warning Indicator ..	Part of instrument cluster .....
Check Engine Warning Indicator .....	Part of instrument panel .....
Ignition Switch .....	Attached to steering column .....
Key Switch .....	Part of ignition switch .....
Parking Brake Switch ....	On parking brake bracket .....
Seatbelt Switch .....	In driver's seatbelt buckle .....
Seatbelt Warning Buzzer/Chime .....	Attached in left center of I/P .....

Refer to the **Location Index** in the back of the manual for connector, ground, and splice descriptions and locations.

### TROUBLESHOOTING HINTS — WARNING INDICATORS

CONDITION	POSSIBLE CAUSE	ACTION
<ul style="list-style-type: none"> <li>• Any Warning Indicator lights when systems are normal</li> </ul>	<ul style="list-style-type: none"> <li>• Defective switch</li> <li>• Shorts to ground in wiring between Instrument Cluster and any switch</li> </ul>	<ul style="list-style-type: none"> <li>• Check switches providing ground path to indicator</li> <li>• Check resistance of wiring between cluster and chassis ground</li> </ul>
<ul style="list-style-type: none"> <li>• Warning Indicator doesn't light</li> </ul>	<ul style="list-style-type: none"> <li>• Blown bulb</li> <li>• No continuity from printed circuit to ground</li> <li>• No voltage at R/Y wire at C208</li> <li>• Open in Instrument Cluster printed circuit</li> </ul>	<ul style="list-style-type: none"> <li>• Replace bulb</li> <li>• Check for any open wires or switches</li> <li>• Check for open in wire or Fuse 18</li> <li>• Repair/Replace as required</li> </ul>

## KEY WARNING

### HOW THE CIRCUIT WORKS

Battery voltage is applied at all times through **Fuse 8** to the **LH Front Door Jamb Switch**. When the **LH Front Door** is opened, the **Door Jamb Switch** closes and battery voltage is applied through the **Warning Buzzer/Chime** to the **Key Switch**. Battery voltage is also applied at all times through **Fuse 4** to the **Main Light Switch**. When the **Main Light Switch** is turned to **PARK** or **HEAD**, voltage is applied through the Switch to the **Warning Buzzer/Chime**. Whenever the key is in the **Ignition**, the **Key Switch** is closed and provides a ground for the **Warning Buzzer/Chime**. Therefore, with the **Lights ON** and/or the **LH Front Door** open, the **Warning Buzzer/Chime** will sound if the key is in the **Ignition**.

Refer to section 33-01 of the shop manual.

### TROUBLESHOOTING HINTS — SEATBELT WARNING

CONDITION	POSSIBLE CAUSE	ACTION
<ul style="list-style-type: none"> <li>No Seatbelt Warning Indicator Buzzer/Chime operation</li> </ul>	<ul style="list-style-type: none"> <li>No voltage at R/Y buzzer/chime wire</li> <li>No continuity to ground through BK wire</li> </ul>	<ul style="list-style-type: none"> <li>Check Fuse 18 and wiring</li> <li>Check for open in BK wire</li> </ul>
<ul style="list-style-type: none"> <li>Seatbelt Indicator does not light</li> </ul>	<ul style="list-style-type: none"> <li>Blown Bulb</li> <li>No voltage at DG/LG wire of C208A when buzzer is on</li> <li>No continuity from BK wire of C208A to G701</li> <li>Defective buzzer/chime</li> </ul>	<ul style="list-style-type: none"> <li>Replace bulb</li> <li>Check for open in wire</li> <li>Check for open in BK wire</li> <li>Replace with known good buzzer/chime</li> </ul>
<ul style="list-style-type: none"> <li>Buzzer/Chime doesn't sound</li> </ul>	<ul style="list-style-type: none"> <li>No continuity to ground from BR/LB wire of buzzer/chime</li> <li>No voltage on R/Y wire at buzzer/chime</li> <li>Defective buzzer/chime</li> </ul>	<ul style="list-style-type: none"> <li>Check for open in BK wire</li> <li>Check for open in R/Y wire or Fuse 18</li> <li>Replace with known good buzzer/chime</li> </ul>

### TROUBLESHOOTING HINTS — KEY WARNING

CONDITION	POSSIBLE CAUSE	ACTION
<ul style="list-style-type: none"> <li>Key Warning Buzzer/Chime does not sound</li> </ul>	<ul style="list-style-type: none"> <li>No voltage at R/PK wire</li> <li>No continuity to ground from BK/PK wire of buzzer/chime</li> </ul>	<ul style="list-style-type: none"> <li>Check Fuse 8, R/PK buzzer wire, and LH Door Jamb Switch for open</li> <li>Apply ground to both ground pins of buzzer/chime. If buzzer/chime operates, repair opens in ground</li> </ul>

# 72 WARNING INDICATORS (DIESEL)

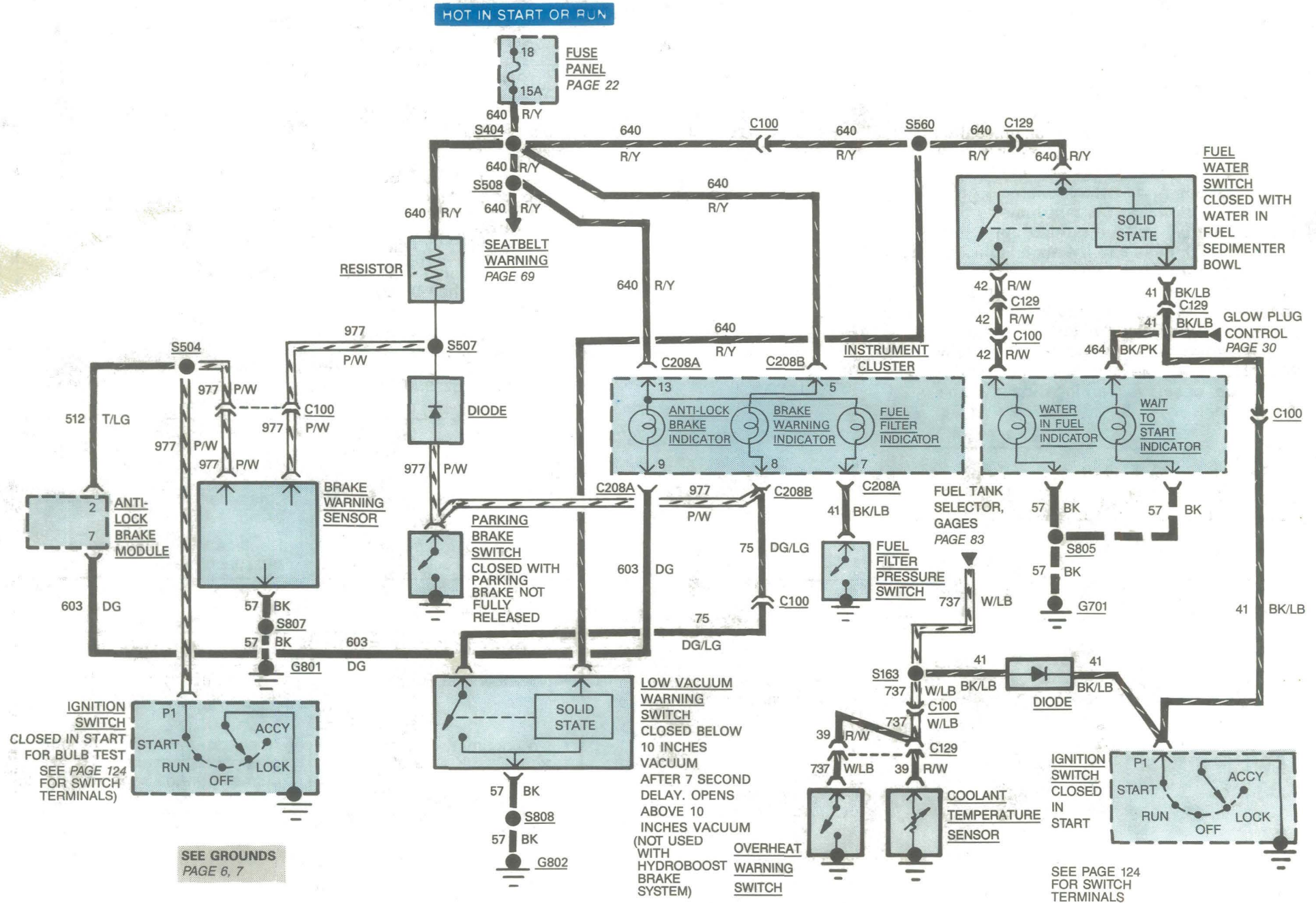

## HOW THE CIRCUIT WORKS

With the **Ignition Switch** in START or RUN, the **Diesel Warning Indicators** are powered through **Fuse 18**. With the **Ignition Switch** in START, the indicators are grounded for a bulb test.

The **Brake Warning Indicator** goes on:

1. With the **Ignition Switch** in START, to test the bulb. (This connection is closed just before the **Starter Relay** pulls in.)
2. When the brakes are applied and either front or rear brake system has failed (low pressure).
3. When the **Parking Brake Switch** closes.
4. When the **Low Vacuum Warning Switch** closes.

The **Low Vacuum Warning Switch** (not used with Hydroboost brake system) closes when manifold vacuum falls below 10 inches. The **Parking Brake Switch** closes when the parking brake is engaged.

There is a 7-second delay after the **Low Vacuum Warning Switch** opens or closes to prevent nuisance flashing of the Brake Indicator. Note that a belt driven vacuum pump is used with the diesel engine to supply vacuum. When the engine has been off for several minutes or more and vacuum has bled down, the **Brake Indicator** will come on as soon as the **Ignition Switch** is turned to RUN. The indicator will stay on even after the engine is started until vacuum has reached a normal level.

### CAUTION

*Do not drive vehicle until the brake indicator goes out. Greatly increased pedal effort is required to stop without vacuum assistance for the brakes.*

## COMPONENT LOCATION

Page-  
Figure

Anti-lock Brake Module . . .	Behind I/P left of center . . . . .
Anti-lock Brake Indicator . . . .	Part of instrument cluster . . . . .
Brake Warning Sensor . . . . .	Part of master cylinder . . . . .
Fuel Filter Indicator . . . . .	Part of instrument cluster . . . . .
Fuel Filter Pressure Switch . . . . .	Part of fuel filter on upper RH front of engine . . . . .
Coolant Temperature Sensor . . . . .	On LH front of engine . . . . .34-2
Diesel/Warning Lamp Module . . . . .	Behind LH side of I/P near fuse panel . . . . .
Fuel Water Switch . . . . .	Part of fuel filter on upper RH front of engine . . . . .
Low Vacuum Warning Switch (Not with Hydroboost Brake System) . . . . .	On RH fender apron . . . . .
Overheat Warning Switch . . . . .	On LH side of engine . . . . .34-2
Parking Brake Switch . . . . .	On parking brake bracket . . . . .

Refer to the **Location Index** in the back of the manual for connector, ground, and splice descriptions and locations.

## TROUBLESHOOTING HINTS

CONDITION	POSSIBLE CAUSE	ACTION
<ul style="list-style-type: none"> <li>• Any Warning Indicator lights when systems are normal</li> </ul>	<ul style="list-style-type: none"> <li>• Defective switch</li> <li>• Shorts to ground in wiring between warning bulb and switch</li> </ul>	<ul style="list-style-type: none"> <li>• Check switches providing ground path for indicator</li> <li>• Repair shorts in wiring as required</li> </ul>
<ul style="list-style-type: none"> <li>• Any Warning Indicator doesn't light</li> </ul>	<ul style="list-style-type: none"> <li>• Blown bulb</li> <li>• Poor ground connection from bulb</li> <li>• No voltage at R/Y, R/W, or BK/PK wire at affected bulb with Ignition Switch in RUN</li> </ul>	<ul style="list-style-type: none"> <li>• Replace bulb</li> <li>• Clean/Tighten connection or repair open in wiring</li> <li>• Repair opens in wiring</li> </ul>

## 74 WARNING INDICATORS (DIESEL)

The **Fuel Water Switch** senses water in the fuel/water separator sediment bowl. The switch will close with water in the sediment bowl and the **Water-In-Fuel Indicator** will go on. See Shop Manual section 25-50 for draining instructions.

The **Fuel Filter Indicator** lights when the **Fuel Filter Pressure Switch** closes as a result of a clogged Fuel Filter.

Refer to section 33-01 of the shop manual.

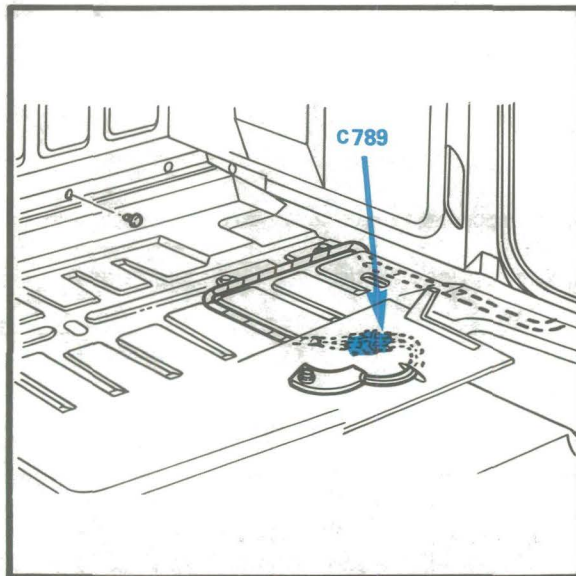

Figure 1 – Seat Belt Wiring (Super Cab)

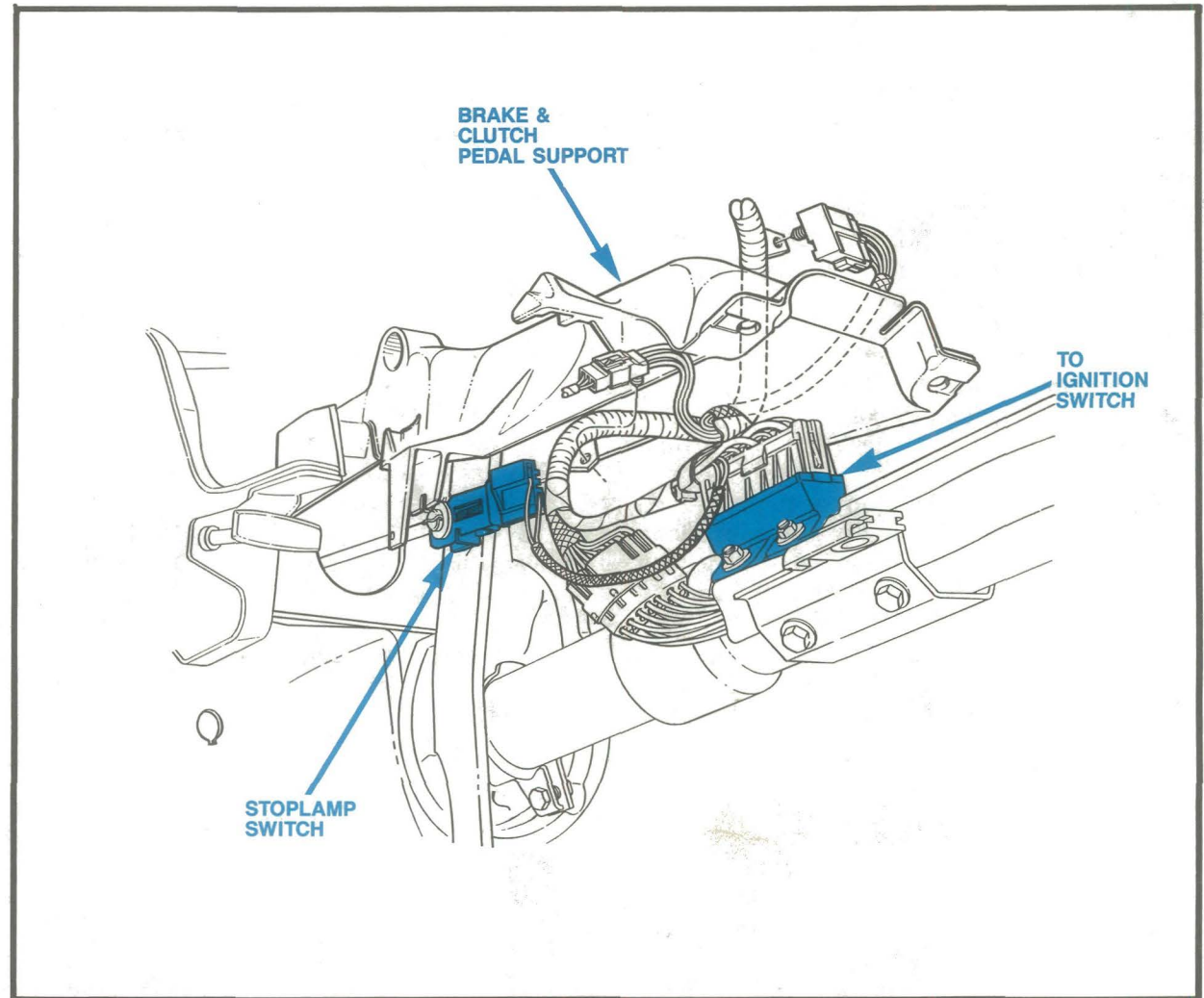
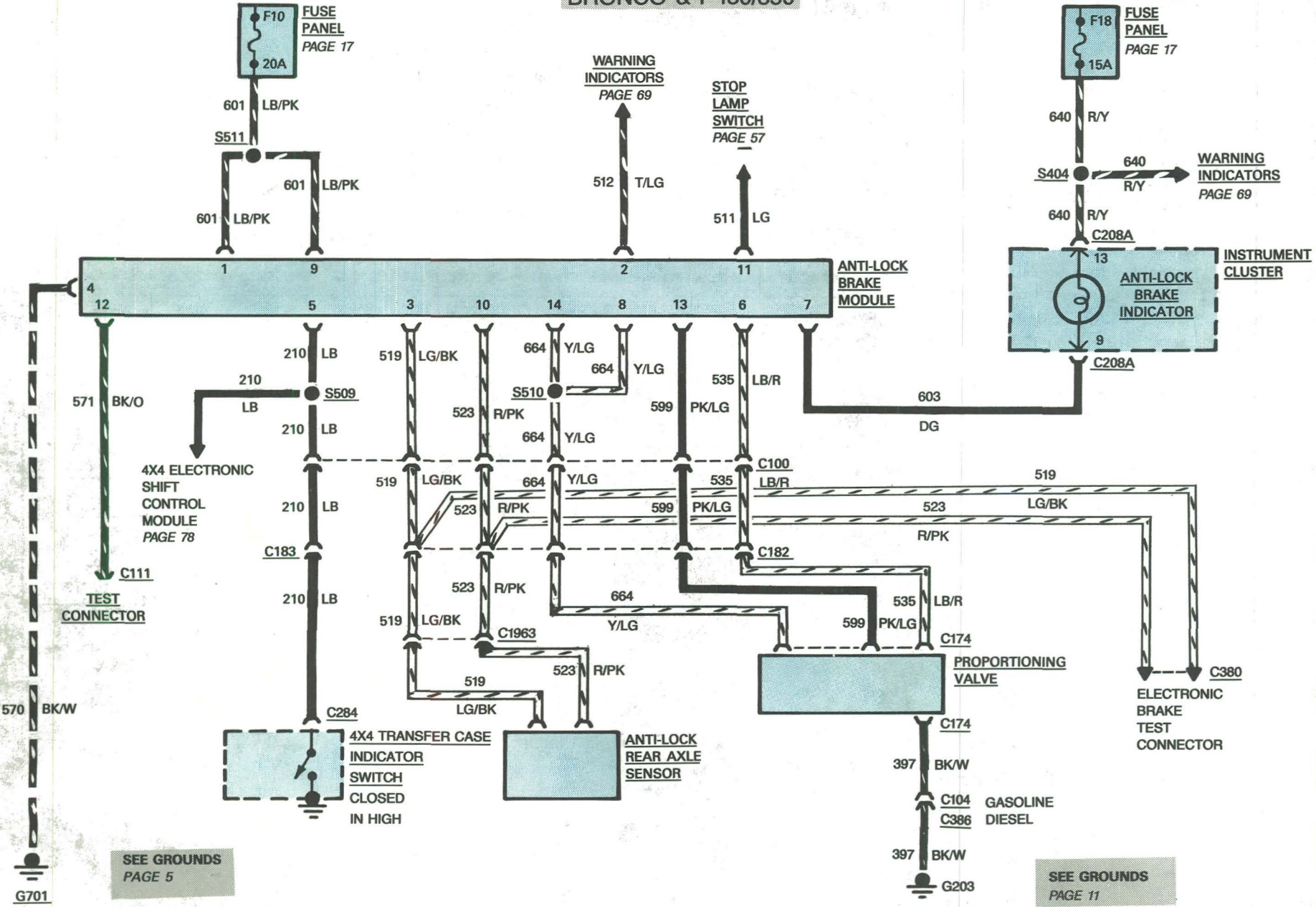

Figure 2 – Stop Lamp Switch

## BRONCO & F-150/350

HOT IN ACCY OR RUN

HOT IN START OR RUN



SEE GROUNDS PAGE 5

SEE GROUNDS PAGE 11

## HOW THE CIRCUIT WORKS

The **Anti-lock Brake System** is powered thru **Fuse 10** with the **Ignition Switch** in ACCY or RUN. The **Anti-lock Indicator** is powered thru **Fuse 18**.

The **Anti-lock Brake Module** processes signals from the **Rear Axle Sensor**, **Stop Lamp Switch** and **4 Wheel Drive Indicator Switch** to energize the **Electronic Rear Brake Proportioning (ERBP) Valve** to first isolate the **Rear Wheel Cylinders** from the **Master Cylinder**. If the signals indicate that rear wheel lock-up is still impending then the **ERBP Valve** is energized with rapid pulses to bleed sufficient fluid from the isolated rear brake system to prevent lock-up.

Refer to section 12-01 of the shop manual.

## COMPONENT LOCATION

Page-  
Figure

Anti-lock Brake Indicator . . . . .	Part of instrument panel . . . . .
Anti-lock Brake Module . . . . .	Behind I/P left of center . . . . .
Anti-lock Rear Axle Sensor . . . . .	At rear axle . . . . .
Electronic Rear Brake Proportioning Valve . . . . .	Inside of LH frame rail behind # crossmember . . . . .
4x4 Indicator Switch . . . . .	On transfer case . . . . .

Refer to the **Location Index** in the back of the manual for connector, ground, and splice descriptions and locations.

## TROUBLESHOOTING HINTS

CONDITION	POSSIBLE CAUSE	ACTION
<ul style="list-style-type: none"> <li>• Anti-lock Indicator is lit.</li> </ul>	<ul style="list-style-type: none"> <li>• Defect in Anti-lock Brake System</li> </ul>	<ul style="list-style-type: none"> <li>• Ground the test connector terminal C380 to obtain a diagnostic code from the Anti-lock Indicator. See Shop Manual Section 12-01 for more information.</li> </ul>

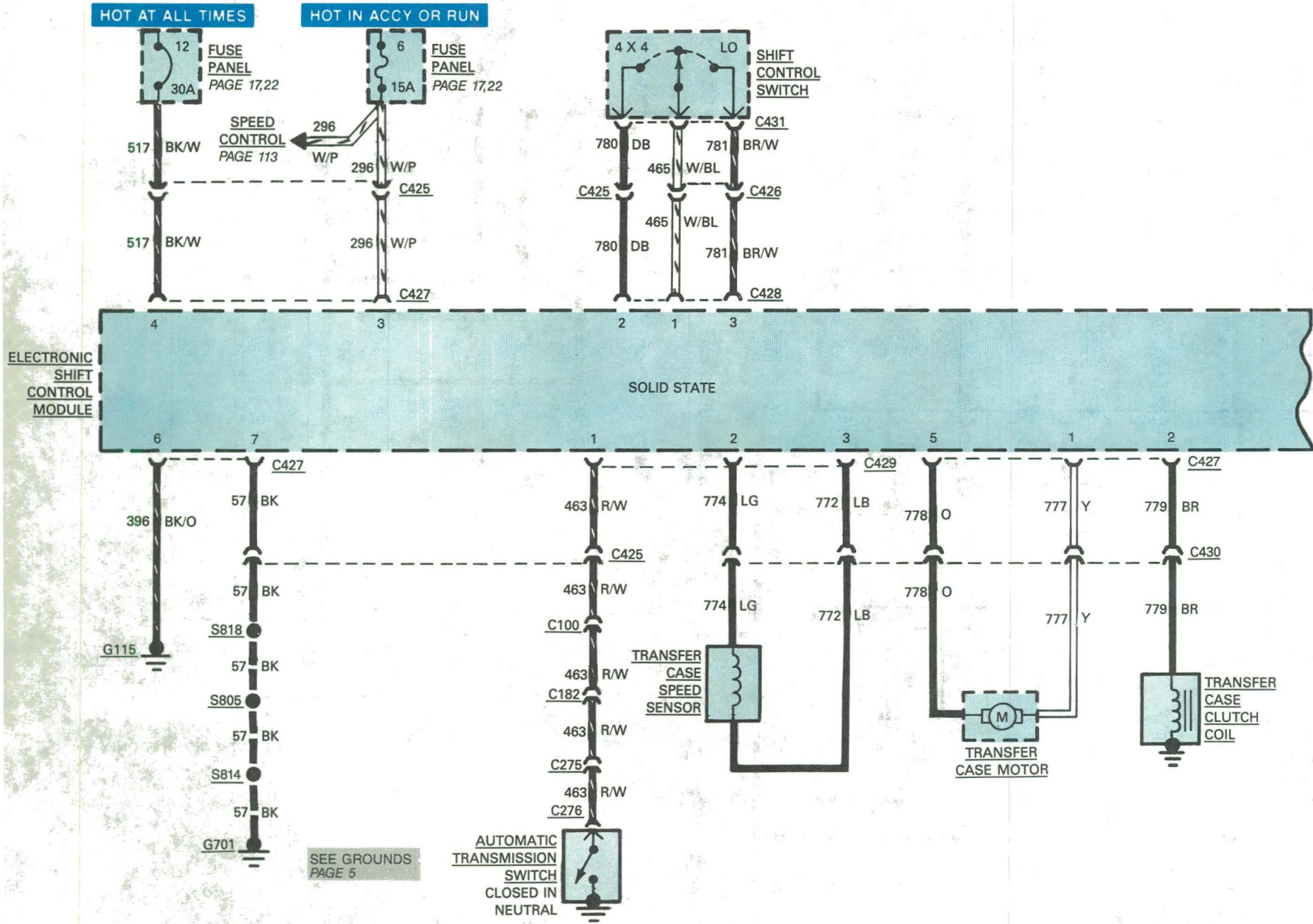

# 78 ELECTRONIC SHIFT — 4-WHEEL DRIVE/4-WHEEL DRIVE INDICATOR

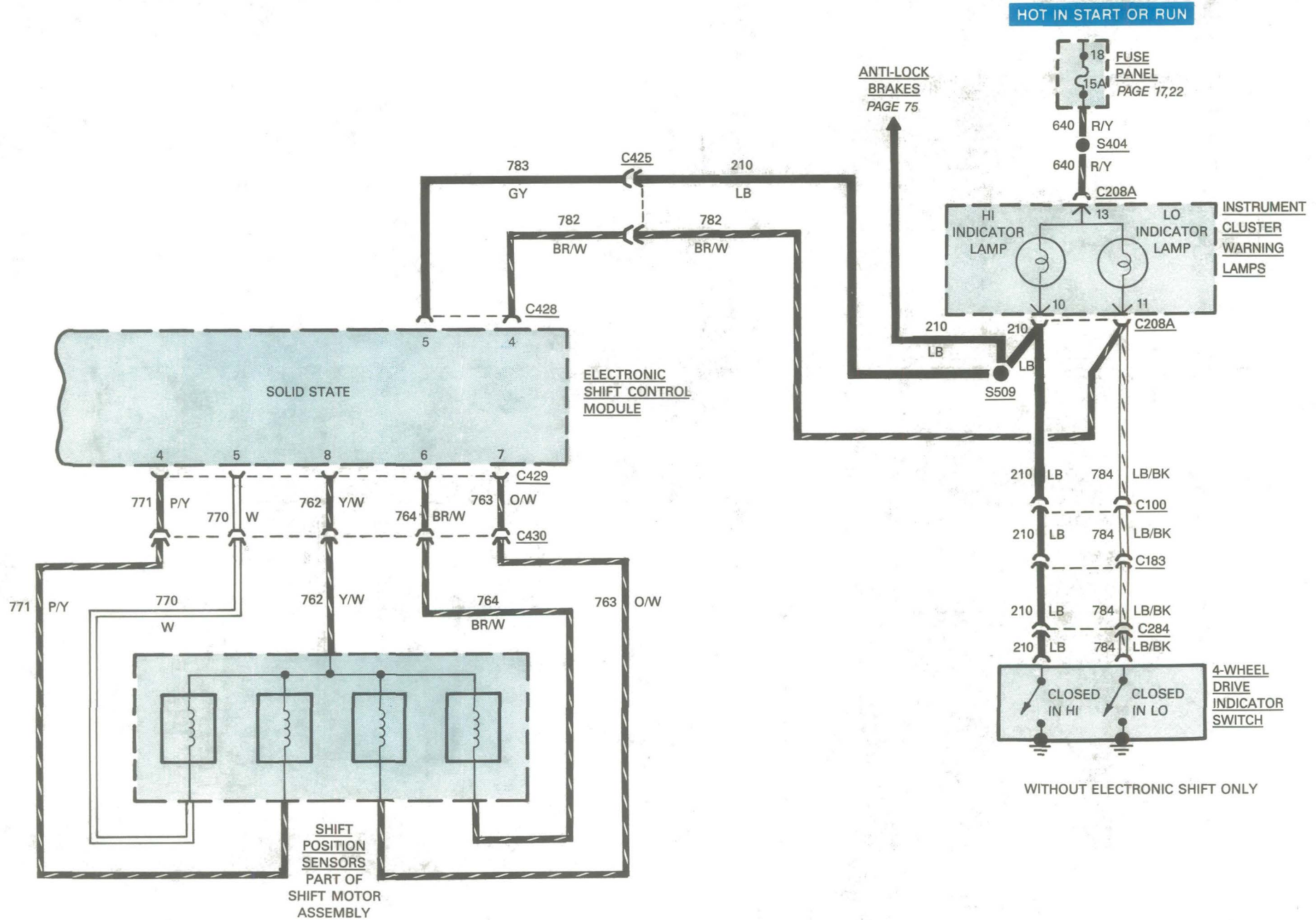

## 4-WHEEL DRIVE INDICATOR

### HOW THE CIRCUIT WORKS

With the **Ignition Switch** in ACCY or RUN and 4-wheel drive engaged, battery voltage is applied through **Fuse 18** to the **4-Wheel Drive Indicator** to light the appropriate indicator lamp.

Refer to **section 33-01** of the shop manual.

## ELECTRONIC SHIFT — 4-WHEEL DRIVE

### HOW THE CIRCUIT WORKS

When the **Shift Control Switch** is placed in 4x4 or Low, the **Electronic Shift Control Module** will analyze information from the **Shift Position Sensors** to determine their current positions. It will also analyze information inputs from the **Transfer Case Speed Sensor** and the **Automatic Transmission Switch**. The **Electronic Shift Control Module** will then activate the **Transfer Case Motor** to produce the desired shift, and the **4-Wheel Drive Indicator** will be illuminated.

Refer to **section 16-01** of the shop manual.

## COMPONENT LOCATION

Page-  
Figure

Automatic Transmission Switch Electronic Shift Control Module Shift Control Switch Hi Indicator Lamp Lo Indicator Lamp Shift Position Sensors Transfer Case Clutch Coil Transfer Case Motor Transfer Case Speed Sensor 4 Wheel Drive Indicator Switch	In automatic transmission RH cowl panel On LH side of I/P Part of instrument cluster Part of instrument cluster Inside transfer case Inside transfer case Inside transfer case Inside transfer case On transfer case	..... ..... 80-1 ..... ..... ..... 80-2 ..... ..... 80-2 ..... ..... .....
--	---	---

Refer to the **Location Index** in the back of the manual for connector, ground, and splice descriptions and locations.

## TROUBLESHOOTING HINTS — 4-WHEEL DRIVE INDICATOR

CONDITION	POSSIBLE CAUSE	ACTION
<ul style="list-style-type: none"> <li>• Indicator does not light</li> </ul>	<ul style="list-style-type: none"> <li>• No voltage at R/Y wire of warning lamps</li> <li>• Blown Bulb</li> </ul>	<ul style="list-style-type: none"> <li>• Check Fuse 18 and wiring</li> <li>• Replace bulb</li> </ul>

## TROUBLESHOOTING HINTS — ELECTRONIC SHIFT

CONDITION	POSSIBLE CAUSE	ACTION
<ul style="list-style-type: none"> <li>Electronic Shift does not operate</li> </ul>	<ul style="list-style-type: none"> <li>No voltage at BK/W or W/P wires of Electronic Shift Module</li> <li>Defective Shift Control Switch</li> <li>Defective Transfer Case Motor</li> <li>Frayed or damaged wires or loose connections</li> </ul>	<ul style="list-style-type: none"> <li>Check Circuit Breaker 12, Fuse 6 and wiring</li> <li>Replace switch as required</li> <li>Replace as required</li> <li>Repair as required</li> </ul>

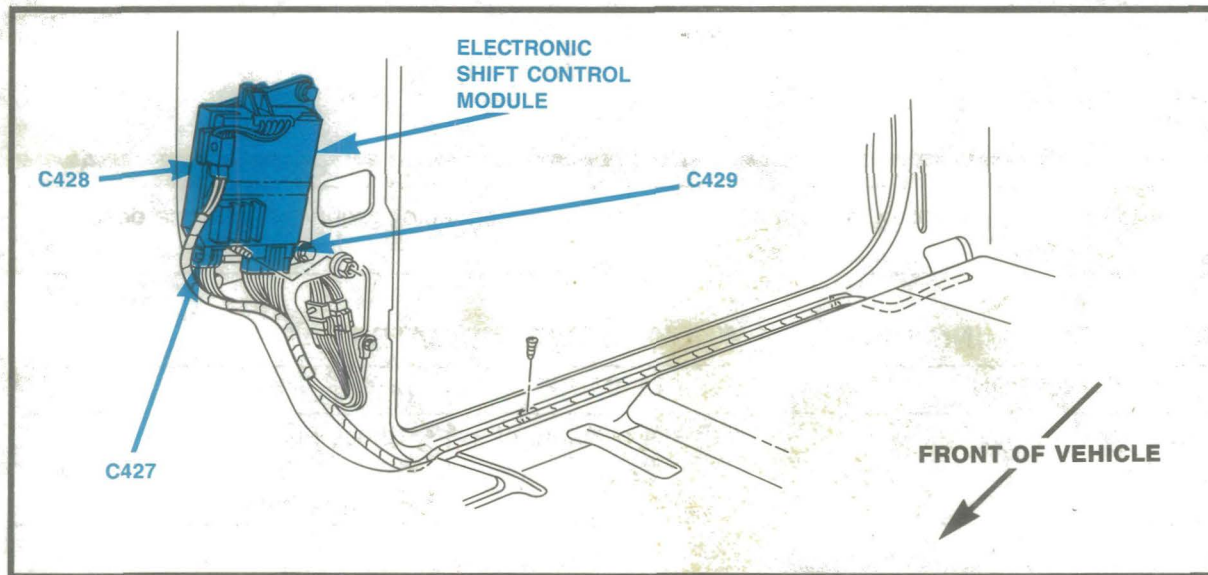

Figure 1 — Electronic Shift Control Module

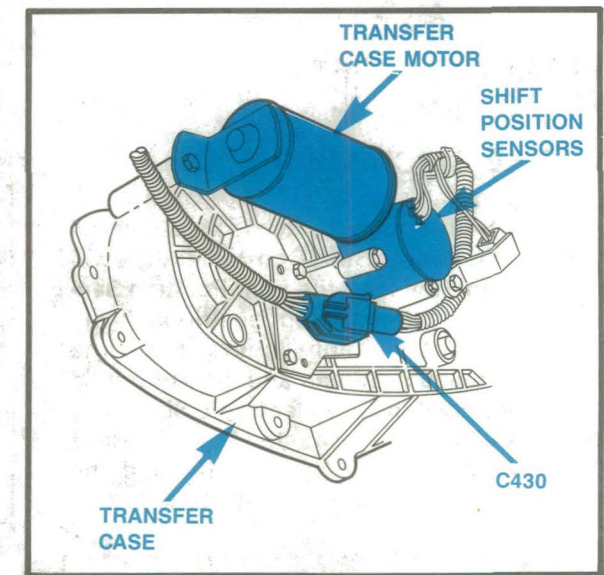
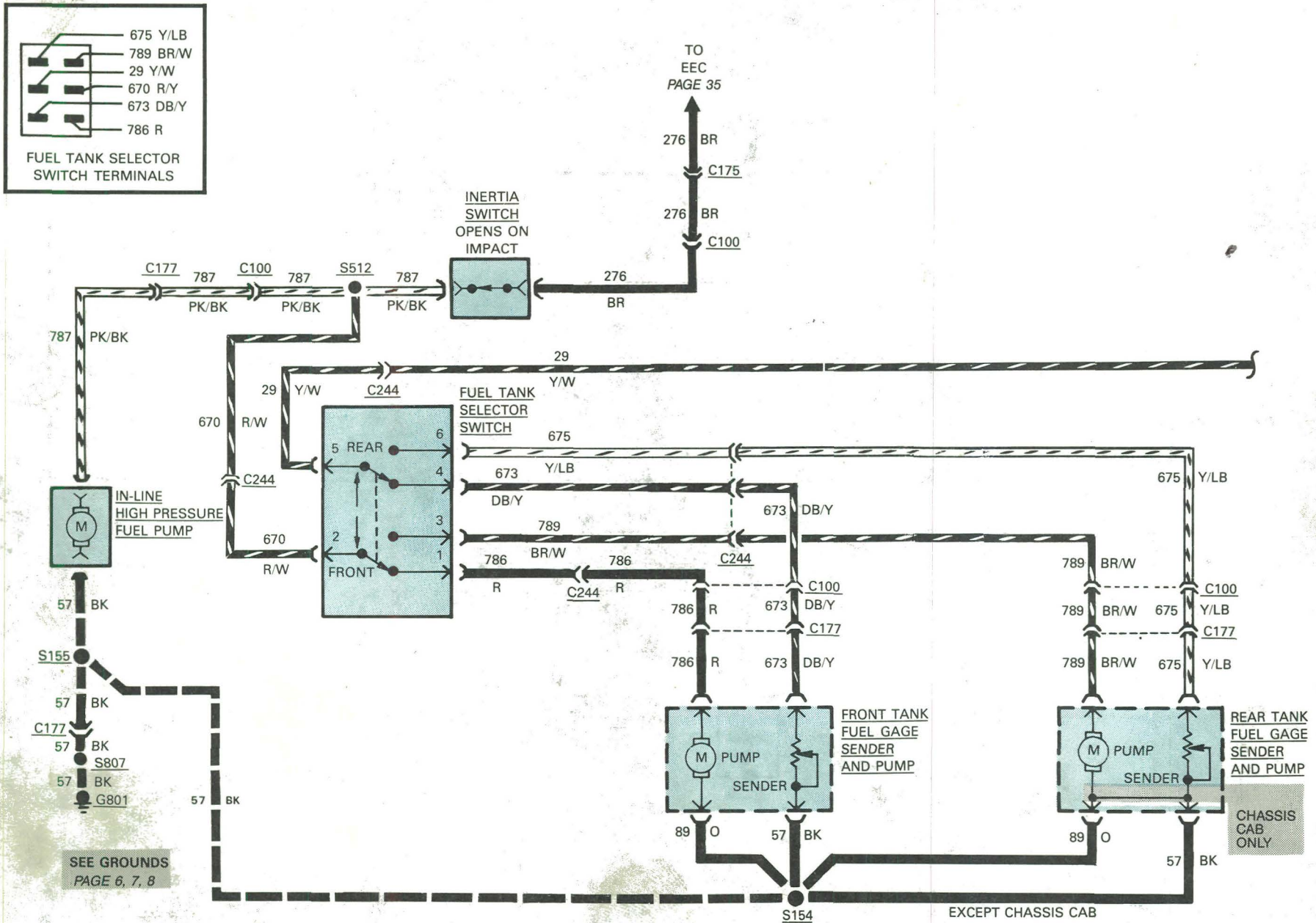
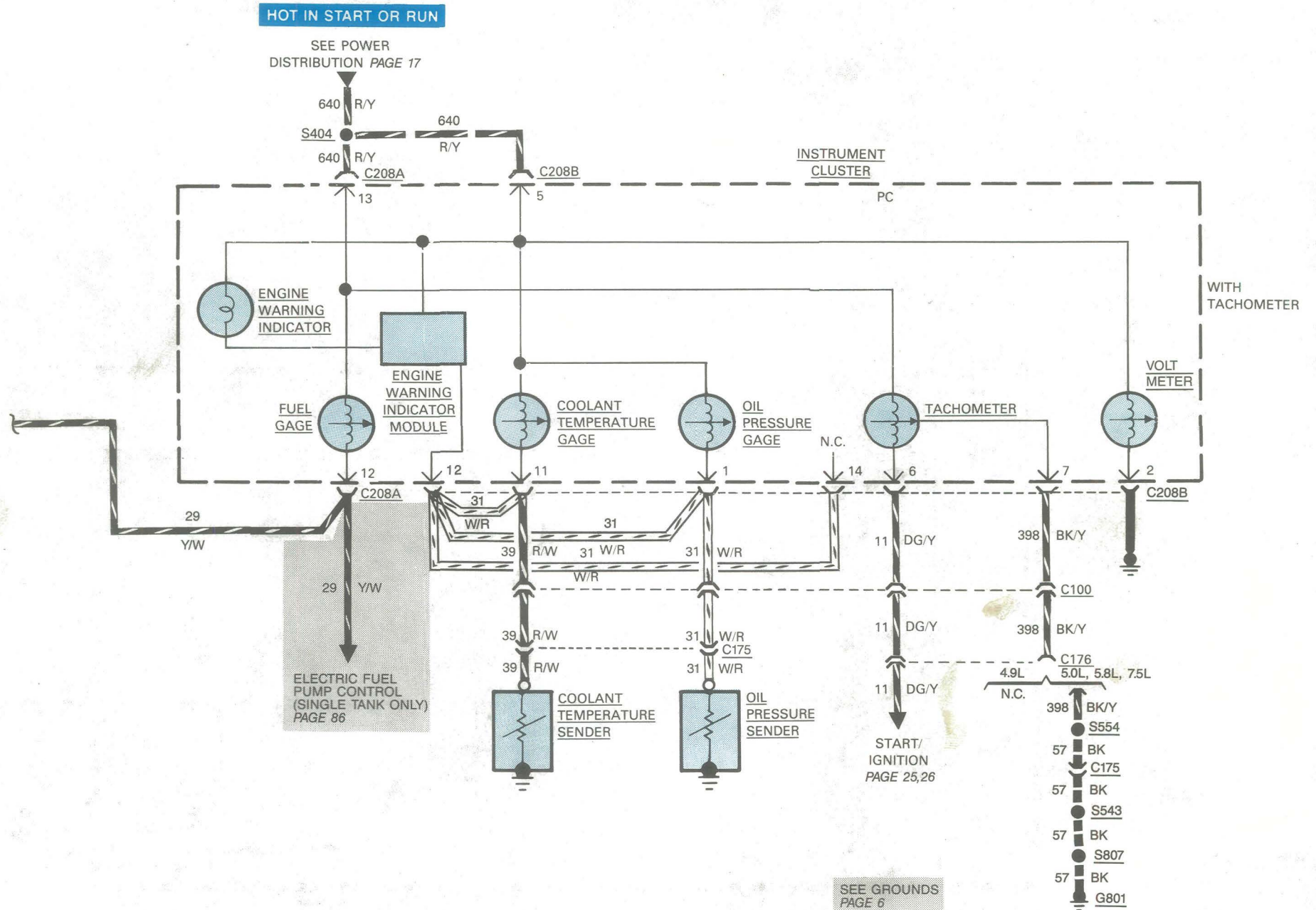

Figure 2 — At Transfer Case

# FUEL TANK SELECTOR/GAGES (FUEL, COOLANT OIL) (DUAL TANKS) 81



# 82 FUEL TANK SELECTOR/GAGES (FUEL, COOLANT OIL) (DUAL TANKS)



HOT IN START OR RUN

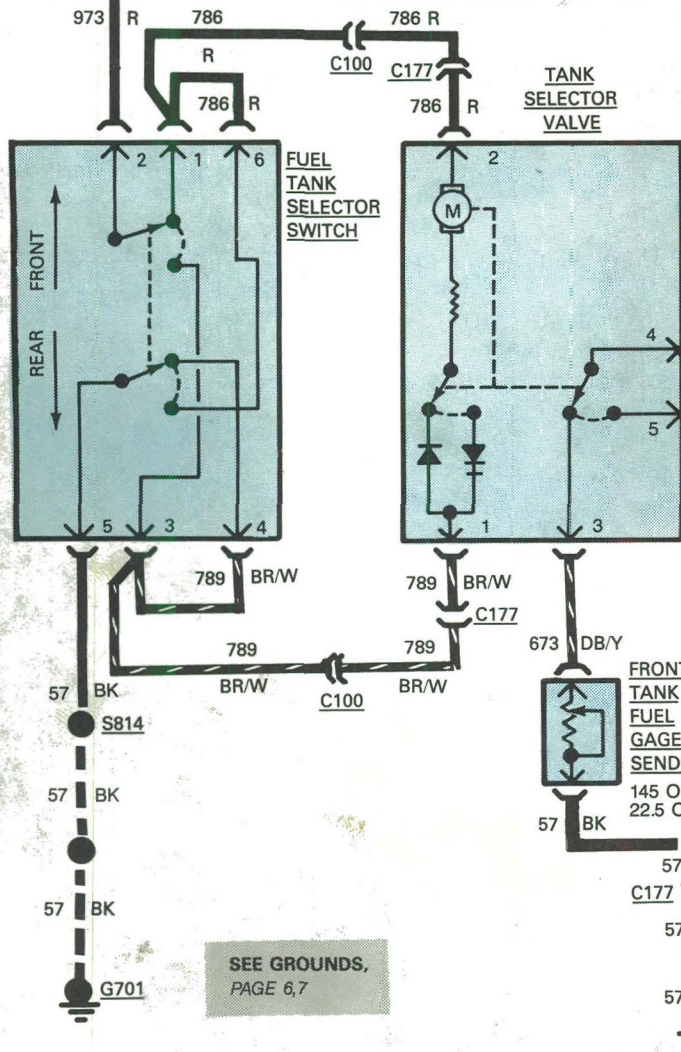
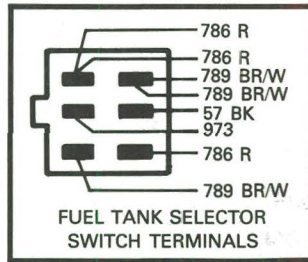

HOT IN START OR RUN

SEE POWER DISTRIBUTION PAGE 17

F-250/SUPER DUTY

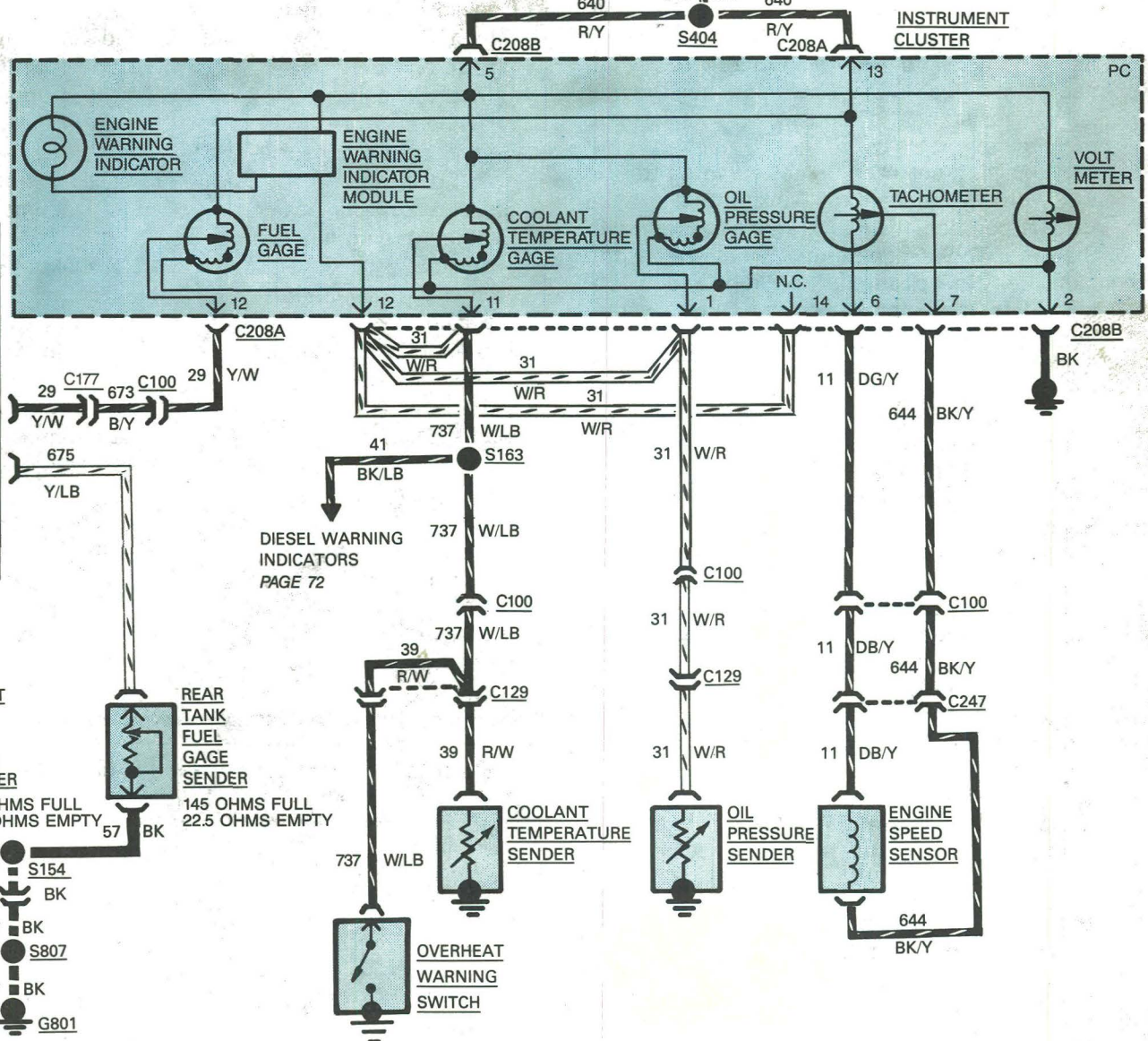

## HOW THE CIRCUIT WORKS

With the **Ignition Switch** in ACCY or RUN, circuit 640 R/Y from **Fuse 18** powers the **Fuel, Coolant Temperature, Oil Pressure Gages, Volt Meter** and, **Tachometer** if so equipped.

The **Fuel Gage** is connected to a **Fuel Gage Sender**. The **Sender** is a variable resistor connected to a float in the fuel tank. When the fuel is low, resistance is high; when fuel is high, resistance is low.

When the **Fuel Tank Selector Switch** for the 7.3L with the optional **Dual Tank** system is in the FRONT position, the **Fuel Gage** is connected to the **Front Tank Gage Sender**. When the switch is in the REAR position, the **Fuel Gage** is connected to the **Rear Tank Fuel Gage Sender**. Voltage is applied through **Fuse 15** and the switch to energize the motor-driven **Tank Selector Valve**. Fuel is then drawn from the rear tank.

The selector valves for the 7.3L engines are motor driven valves, used to switch the **Fuel Gage** between front and rear sending units as well as to switch fuel sources. The **Selector Switch** switches the sending units and In-Tank **Fuel Pumps** for the 4.9L, 5.0L, 5.8L and 7.5L engines.

The **Oil Pressure Gage** is connected to the **Oil Pressure Sender**. The sender is a pressure-sensitive variable resistor. When the oil pressure is low, resistance is high; when the oil pressure is high, resistance is low.

The **Coolant Temperature Gage** connects to the **Coolant Temperature Sender**. The sender is a temperature-sensitive variable resistor. When the coolant temperature is low, resistance is high; when coolant temperature is high, resistance is low.

Refer to section 24-01 of the shop manual.

## COMPONENT LOCATION

	Page-Figure
Coolant Temperature Gage .....	Part of instrument cluster .....
Coolant Temperature Switch (4.9L) .....	Behind #6 exhaust manifold on engine block .....
(5.0L and 5.8L) .....	LH side of intake manifold .....
(7.3L Diesel) .....	LH front of engine .....
(7.5L) .....	LH side of intake manifold .....
Engine Speed Sensor (7.3L Diesel) .....	At injection pump timing gear cover .....
Engine Warning Indicator .....	Part of instrument cluster .....
Engine Warning Indicator Module .....	Part of instrument cluster .....
Front Tank Fuel Gage Sender .....	On tank in front of rear axle .....
Fuel Tank Selector Switch .....	Center of I/P .....
Fuel Tank Selector Valve Solenoid .....	On LH side frame member behind cab .....
Inertia Switch .....	LH dash panel above brake pedal .....
Oil Pressure Gage .....	Part of instrument cluster .....
Oil Pressure Sender (4.9L) .....	On engine block to rear of oil filter .....
(5.0L, 5.8L, 7.5L) .....	LH front of engine .....
(7.3L Diesel) .....	Rear of engine .....
Rear Tank Fuel Gage Sender .....	On tank behind rear axle .....
Tachometer .....	Part of instrument cluster .....

Refer to the **Location Index** in the back of the manual for connector, ground, and splice descriptions and locations.

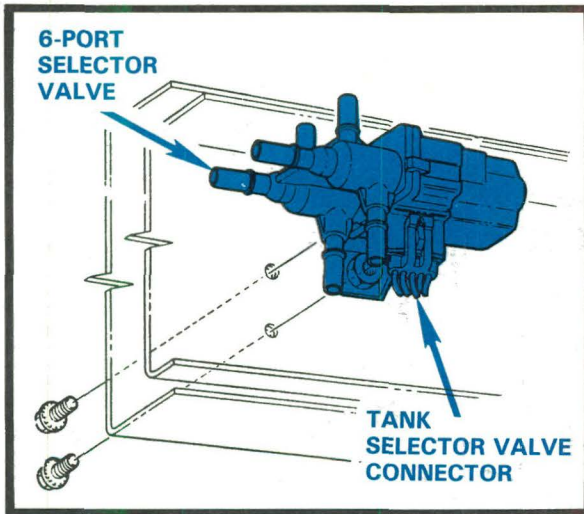

Figure 1 — 6 Port Fuel Tank Selector Valve, LH Side of Mainframe, Aft of Cab — 7.3L Diesel

## TROUBLESHOOTING HINTS

CONDITION	POSSIBLE CAUSE	ACTION
<ul style="list-style-type: none"> <li>Fuel Tank Selector Switch does not work</li> </ul>	<ul style="list-style-type: none"> <li>No voltage at R, Y/W, or R/W wires of switch</li> <li>Defective switch</li> </ul>	<ul style="list-style-type: none"> <li>Check Fuses 15 and 18 and wiring</li> <li>Replace switch as required</li> </ul>
<ul style="list-style-type: none"> <li>One Gage doesn't work</li> </ul>	<ul style="list-style-type: none"> <li>Poor ground connection to BK wire of sender</li> <li>Broken or corroded terminals at sender</li> <li>Open circuit in gage or wiring</li> </ul>	<ul style="list-style-type: none"> <li>Clean/Tighten connection or repair any open in wiring</li> <li>Clean/Replace</li> <li>Replace gage or repair open in wiring</li> </ul>
<ul style="list-style-type: none"> <li>Incorrect gage readings</li> </ul>	<ul style="list-style-type: none"> <li>Gage out of calibration</li> </ul>	<ul style="list-style-type: none"> <li>Replace gage with known good gage.</li> </ul>



## HOW THE CIRCUIT WORKS

### SINGLE TANK

The fuel delivery system consists of two electric fuel pumps. A low pressure **In-Tank Fuel Pump** which pumps fuel into a reservoir, and a high pressure In-Line Pump, which takes fuel from the **Reservoir** and pumps fuel to the **Fuel Injectors**.

With the **Ignition Switch** in START or RUN, Voltage is applied to **Fuel Pump Relay** through **Fuse Link M**. When the **Fuel Pump Relay** receives a signal from the **EEC Module** and with the **Inertia Switch** closed, power is applied to the **Fuel Pumps**.

When voltage is applied to the low pressure **Fuel Pump**, the **Reservoir** is filled with fuel. This **Reservoir** assures that adequate fuel flow is available to the high pressure **Fuel Pump** when climbing steep grades and during hard cornering, when the **In-Tank Fuel Pump** may be starved of fuel.

### DUAL TANKS

The **Electric Fuel Pump Control** for **Dual Tanks** consists of three electric fuel pumps. Two low pressure (**C68 In-Tank Fuel Pumps**) located in both the front and rear tanks, pump fuel into a reservoir. A high pressure **In-Line Fuel Pump** then takes the fuel from the **Reservoir** to the **Fuel Injectors**.

This system allows fuel to be drawn from either the **Front** or **Rear Fuel Tank Unit**. With the **Ignition Switch** in START or RUN, voltage is applied through **Fuse Link M** to the **Fuel Pump Relay**. When the **Fuel Pump Relay** receives a signal from the **EEC Module** and the **Inertia Switch** is closed, power is supplied to the **In-Line**

## COMPONENT LOCATION

Page-  
Figure

Fuel/Gage Sender and Pump .....	At tank in front of rear axle .....	56-10,11,12
Inertia Switch .....	LH dash panel above brake pedal .....	

Refer to the **Location Index** in the back of the manual for connector, ground, and splice descriptions and locations.

## TROUBLESHOOTING HINTS

CONDITION	POSSIBLE CAUSE	ACTION
<ul style="list-style-type: none"> <li>Fuel Pump doesn't work</li> </ul>	<ul style="list-style-type: none"> <li>No voltage at PK/BK wire of Fuel Pump</li> <li>Poor ground connection to BK wire</li> <li>Defective Fuel Pump Cutoff Relay</li> <li>Open Inertia Switch</li> </ul>	<ul style="list-style-type: none"> <li>Check Fuse Link M and wiring</li> <li>Clean/Tighten or repair open in wiring</li> <li>Replace with known good relay</li> <li>Replace as required</li> </ul>

**Fuel Pump**, and depending on which position the **Fuel Tank Selector Switch** is in (FRONT OR REAR), to either the **Front** or **Rear In-Tank Fuel Pump**.

The **Fuel Tank Selector Switch** controls which **Fuel Tank Unit** is used. When turned to the Front position, power flows through the Front contacts of the **Fuel Tank Selector Switch** to the fuel pump of the **Front Fuel Tanks**. The sender in the **Front Fuel Tank Unit** is connected simultaneously to the **Fuel Gage**.

When the **Fuel Tank Selector Switch** is turned to REAR, the **Fuel Pump** in the **Rear Fuel Tank Unit** is connected simultaneously to the **Fuel Gage**.

For circuit description and troubleshooting hints of gages, please see pages 84 and 85.

Refer to section 24-01 of the shop manual.

# 88 HORN/CIGAR LIGHTER

HOT AT ALL TIMES

WITHOUT SPEED CONTROL

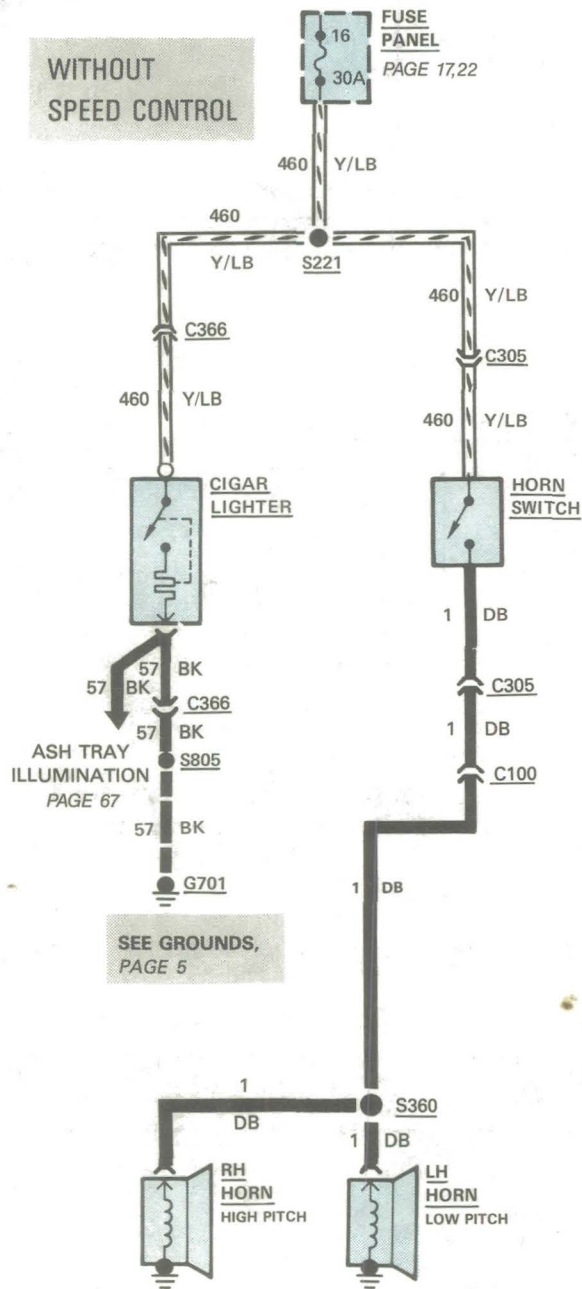

HOT AT ALL TIMES

WITH SPEED CONTROL

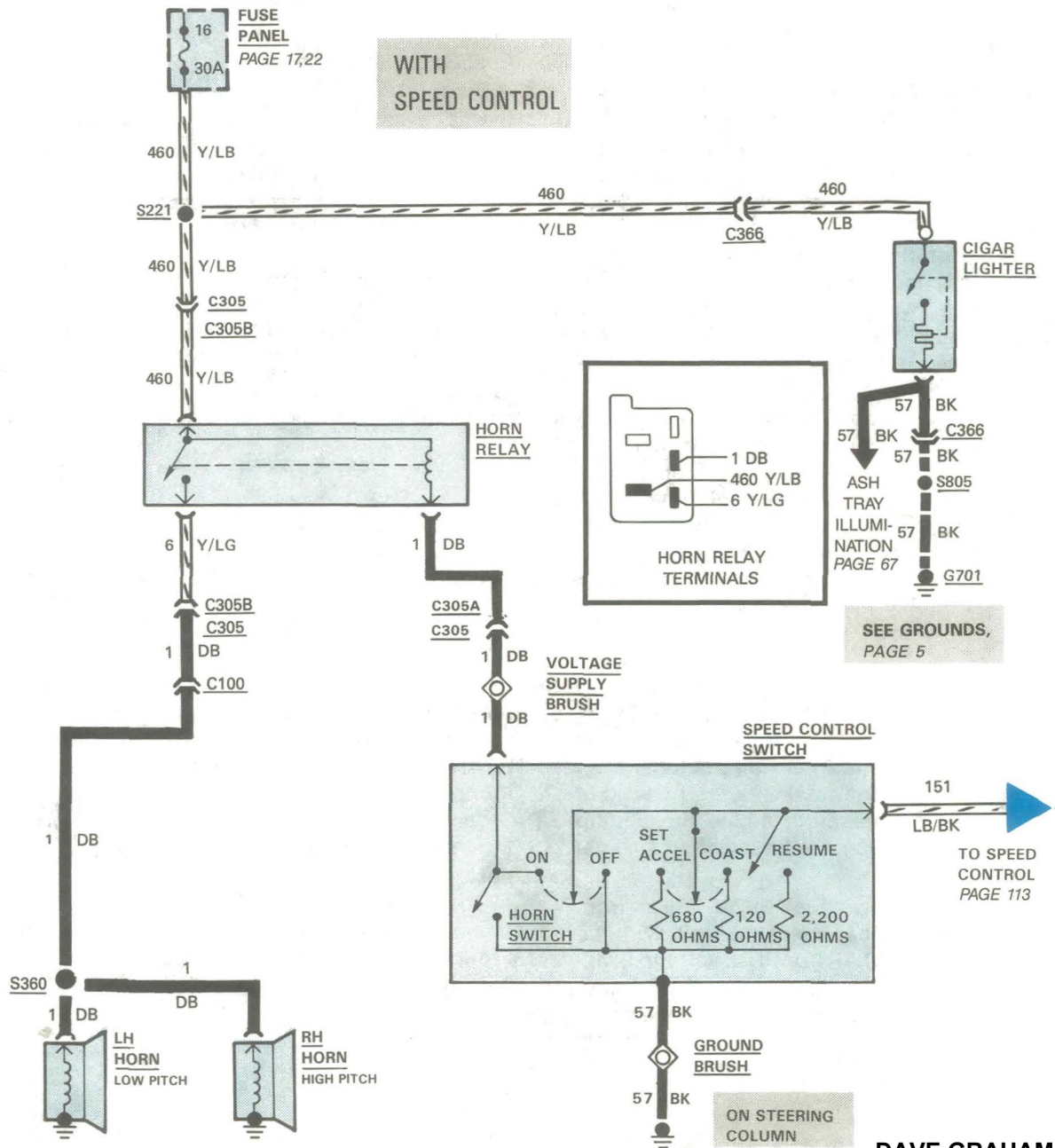

# HORN

## HOW THE CIRCUIT WORKS

### Horns (Without Speed Control)

When the **Horn Switch** is closed, voltage is applied through **Fuse 16** to the **Horns**.

### Horns (With Speed Control)

Pressing the **Horn Switch** energizes the **Horn Relay**. The **Relay** closes, and voltage is applied through **Fuse 16** to the **Horns**.

Refer to section 35-01 of the shop manual.

# CIGAR LIGHTER

## HOW THE CIRCUIT WORKS

Voltage is applied at all times to the **Cigar Lighter**. Pushing in the **Cigar Lighter** closes the switch and allows current to flow through the heating element. The element opens the switch when it is heated.

Refer to section 35-01 of the shop manual.

## COMPONENT LOCATION

Page-Figure

Cigar Lighter .....	Center of I/P .....	
Horns .....	LH front of radiator support .....	90-1
Horn Relay .....	Near speed control amplifier .....	
Horn Switch .....	In steering wheel hub assembly .....	

Refer to the **Location Index** in the back of the manual for connector, ground, and splice descriptions and locations.

## TROUBLESHOOTING HINTS — HORN

CONDITION	POSSIBLE CAUSE	ACTION
<ul style="list-style-type: none"> <li>• Horn does not sound</li> </ul>	<ul style="list-style-type: none"> <li>• No voltage at Y/LB wire of Horn Switch</li> <li>• Horn out of adjustment</li> <li>• Defective Horn</li> </ul>	<ul style="list-style-type: none"> <li>• Check Fuse 16 and wiring</li> <li>• Turn adjusting screw on Horn counterclockwise 1/4 to 3/8 turn and secure</li> <li>• Replace with known good Horn</li> </ul>

## TROUBLESHOOTING HINTS — CIGAR LIGHTER

CONDITION	POSSIBLE CAUSE	ACTION
<ul style="list-style-type: none"> <li>• Cigar Lighter doesn't work</li> </ul>	<ul style="list-style-type: none"> <li>• No voltage at Y/LB wire of Cigar Lighter</li> <li>• Poor continuity to ground at lighter shell</li> </ul>	<ul style="list-style-type: none"> <li>• Check Fuse 16 and wiring</li> <li>• Clean/Tighten connection and check BK wire for opens</li> </ul>

# 90 HORN/CIGAR LIGHTER

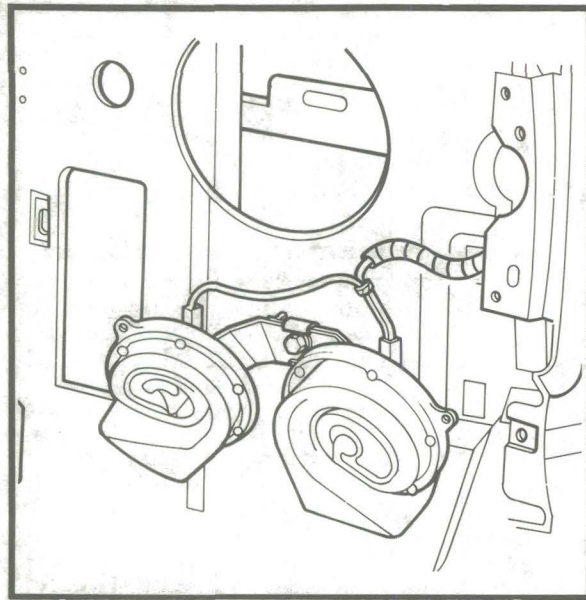

Figure 1 - Forward of Radiator Support, Single Bracket Mounting Dual Horns

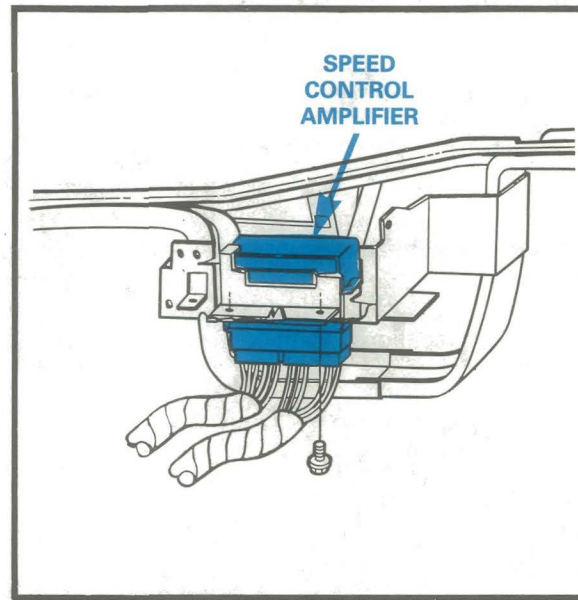
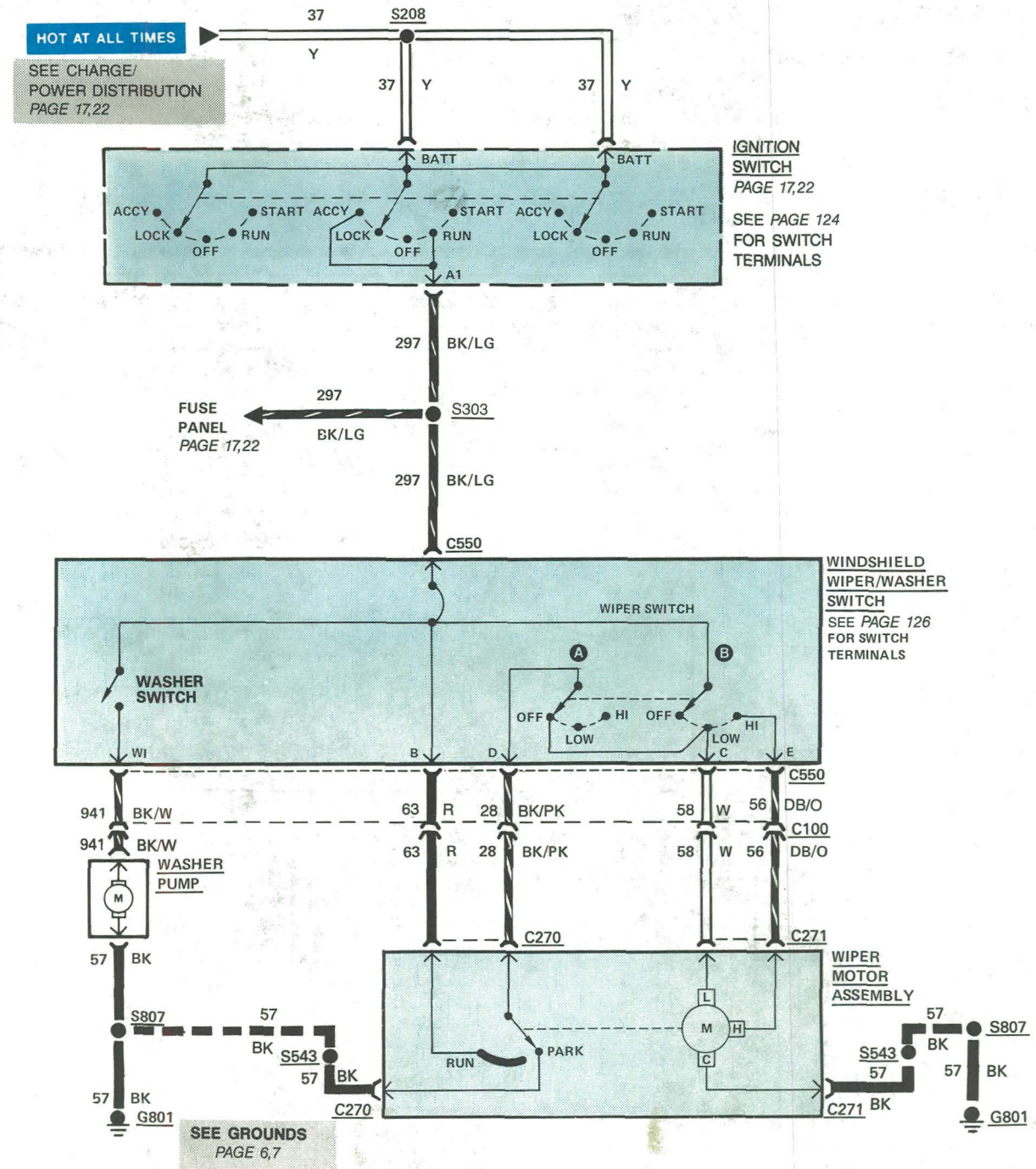

Figure 2 - Behind LH Side of I/P



## HOW THE CIRCUIT WORKS

The **Windshield Wiper/Washer Switch** has both a momentary washer switch and wiper switch. The wiper switch has three positions: OFF, and LO and HI speeds.

**Washer Operation**—Current flows directly to the **Washer Pump** motor as long as the washer switch is depressed.

**Wiper Operation**—The wipers are controlled by the three-position wiper switch and the wiper motor switch. When the wipers are turned OFF, they continue to operate until they return to the PARK position of the wiper motor switch.

In LO or HI current flows through the wiper switch, into the L or H terminal of the **Wiper Motor**, and grounds through the C terminal.

When parking current flows through:

1. the **R** wire to the RUN contact of the wiper motor switch;
2. through the wiper motor switch and the **BK/PK** wire to the wiper switch;
3. through section **A** of the wiper switch and the **W** wire to the **Wiper Motor** L terminal;
4. through **Wiper Motor** C terminal to ground.
5. When the **Wiper Motor** reaches the end of its travel, the wiper motor switch moves to PARK position. In this position, power is removed from the motor, and operation stops.

Refer to section 35-01 of the shop manual.

## COMPONENT LOCATION

Page-  
Figure

Ignition Switch .....	Attached to steering column .....	
Washer Pump .....	In washer reservoir .....	
Windshield Wiper/Washer Switch .....	On LH side of I/P .....	95-2
Wiper Motor Assembly ...	Attached to center of dash panel .....	

Refer to the **Location Index** in the back of the manual for connector, ground, and splice descriptions and locations.

## TROUBLESHOOTING HINTS

CONDITION	POSSIBLE CAUSE	ACTION
<ul style="list-style-type: none"> <li>• Washer Pump doesn't work</li> </ul>	<ul style="list-style-type: none"> <li>• Circuit Breaker in Wiper/Washer Switch is open</li> <li>• Damaged hoses</li> <li>• Defective Pump Motor</li> </ul>	<ul style="list-style-type: none"> <li>• Reset and check for shorts to ground in BK wire</li> <li>• Repair/Replace as required</li> <li>• Replace with known good motor</li> </ul>
<ul style="list-style-type: none"> <li>• Wipers don't work</li> </ul>	<ul style="list-style-type: none"> <li>• Circuit Breaker in Wiper/Washer Switch is open</li> <li>• Defective Wiper Motor</li> <li>• Frayed or damaged wires or loose connections</li> </ul>	<ul style="list-style-type: none"> <li>• Reset and check for shorts to ground in BK wire</li> <li>• Replace with known good motor</li> <li>• Repair/Replace as required</li> </ul>

SEE CHARGE/  
POWER DISTRIBUTION  
PAGE 17,22

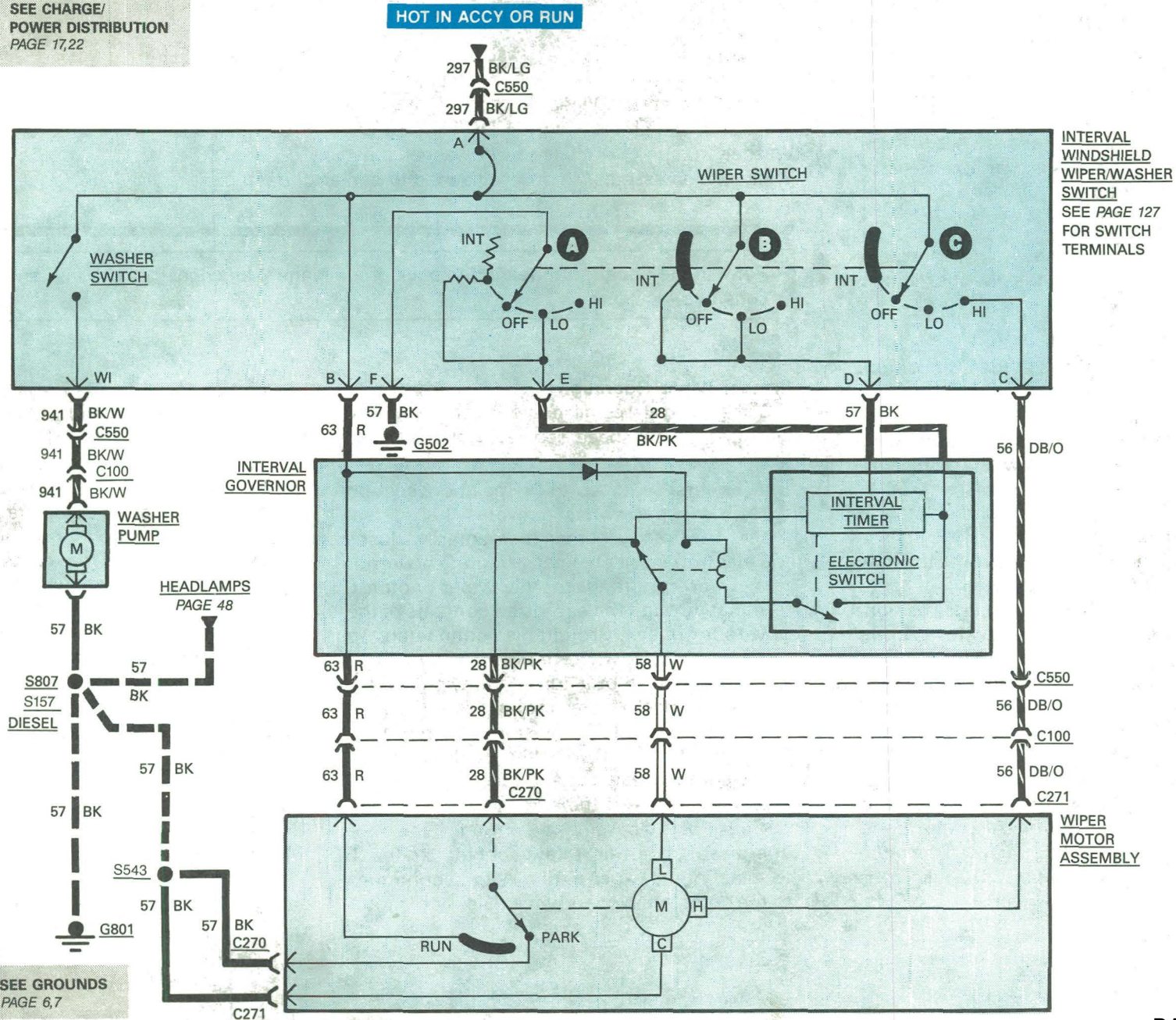

INTERVAL  
WINDSHIELD  
WIPER/WASHER  
SWITCH  
SEE PAGE 127  
FOR SWITCH  
TERMINALS

INTERVAL  
GOVERNOR

INTERVAL  
TIMER  
ELECTRONIC  
SWITCH

WIPER  
MOTOR  
ASSEMBLY

SEE GROUNDS  
PAGE 6,7

## HOW THE CIRCUIT WORKS

The **Interval Windshield Wiper/Washer** allows the driver to select LO speed, HI speed, or INTerval wipe. In INTerval, the wipes can be spaced one second to fifteen seconds apart.

The **Interval Windshield Wiper/Washer Switch** has a momentary washer switch, a four-position wiper switch, and a variable resistor which sets interval time.

### Washer Operation

As long as the washer switch is pressed, current flows directly to the **Washer Pump** motor.

### Wiper Operation

When the wiper switch is in the LO position, section **A** of the wiper switch powers the interval timer input so that the electronic switch is pulled closed. Current then flows through the wiper/washer switch, wire **63R**, the diode, the governor relay coil, wire **58W**, and section **B** of the wiper/washer switch to **G502**. The governor relay coil pulls in the governor switch allowing current to flow through the motor.

When the wiper switch is in the HI position, section **C** of the wiper/washer switch powers the motor through the H terminal.

When the wiper switch is placed in the OFF position, the circuit energizing the **Interval Governor** relay coil is broken. Current to the motor then flows through circuit **63**, the RUN contact of the wiper motor switch, and the de-energized **Interval Governor** relay contacts to the L terminal of the motor. After the completion of one wipe, the wiper motor switch returns to the PARK position. This removes power and the wiper motor stops.

## COMPONENT LOCATION

		Page- Figure
Interval Governor .....	Lower reinforcement of I/P to left side of cowl .....	95-1
Interval Windshield Wiper/Washer Switch .....	On LH side of I/P .....	95-2
Washer Pump .....	In washer reservoir .....	
Wiper Motor Assembly ...	Attached to center of dash panel .....	

Refer to the **Location Index** in the back of the manual for connector, ground, and splice descriptions and locations.

### Interval Wiper Operation

During interval operation, the wipers make single wipes at low speed separated by a variable length pause.

When first switched to INT position, section **A** of the wiper switch activates the interval timer. The interval timer momentarily closes the electronic switch, energizing the governor relay. Current flows to the wiper motor L terminal through the energized contacts of the governor relay. Ground is connected to terminal C of the wiper motor.

As the wiper motor turns, the wiper motor switch changes from the grounded PARK position to the hot RUN position. Current now flows through the R wire, the RUN contact of the wiper motor switch and resets the interval timer, which opens the electronic switch. The current path continues through the de-energized governor relay contact to the L terminal of the wiper motor. Wiping continues to the completion of one wipe. The wiper motor

switch returns to the PARK position contact, power is removed and the wiper motor stops. After a pause (controlled by a variable resistor) the interval timer pulls in the governor relay to start another wipe.

When parking is complete, the wiper motor is braked to a stop by grounding the L and C terminals through the wiper motor switch. Braking takes place when the wiper motor switch moves to the PARK position. The wiper motor L terminal is grounded through the PARK contact of the wiper motor switch and the de-energized contact of the governor relay.

Refer to section 35-01 of the shop manual.

## TROUBLESHOOTING HINTS

CONDITION	POSSIBLE CAUSE	ACTION
<ul style="list-style-type: none"> <li>No Wipers in interval position</li> </ul>	<ul style="list-style-type: none"> <li>Variable resistor of Wiper Switch is defective</li> <li>Defective Interval Governor</li> </ul>	<ul style="list-style-type: none"> <li>Repair/Replace as required</li> <li>Replace as required with known good governor</li> </ul>
<ul style="list-style-type: none"> <li>Interval time is too long</li> </ul>	<ul style="list-style-type: none"> <li>Defective Interval Governor</li> </ul>	<ul style="list-style-type: none"> <li>Replace as required with known good governor</li> </ul>
<ul style="list-style-type: none"> <li>Wipers operate in HI speed only</li> </ul>	<ul style="list-style-type: none"> <li>Poor ground connection on BK wire from Wiper Switch</li> <li>Defective Interval Governor</li> </ul>	<ul style="list-style-type: none"> <li>Clean/Tighten connections and check for opens in BK wire</li> <li>Replace as required with known good governor</li> </ul>

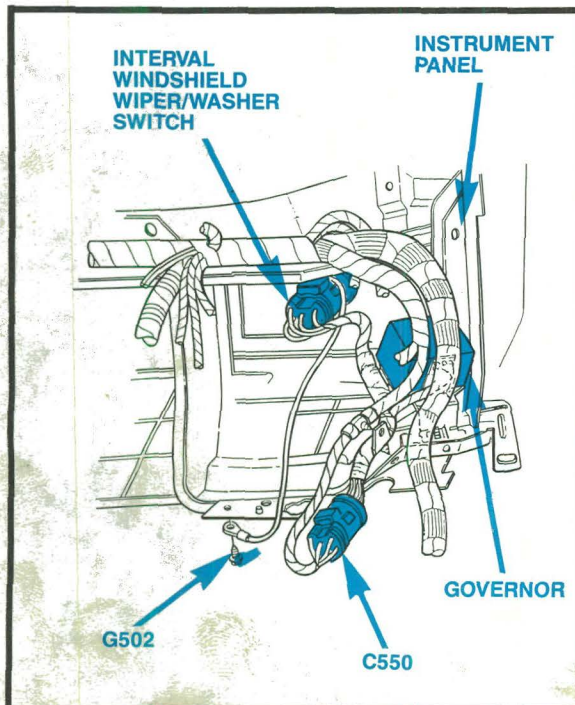

Figure 1 — Behind LH Corner of I/P

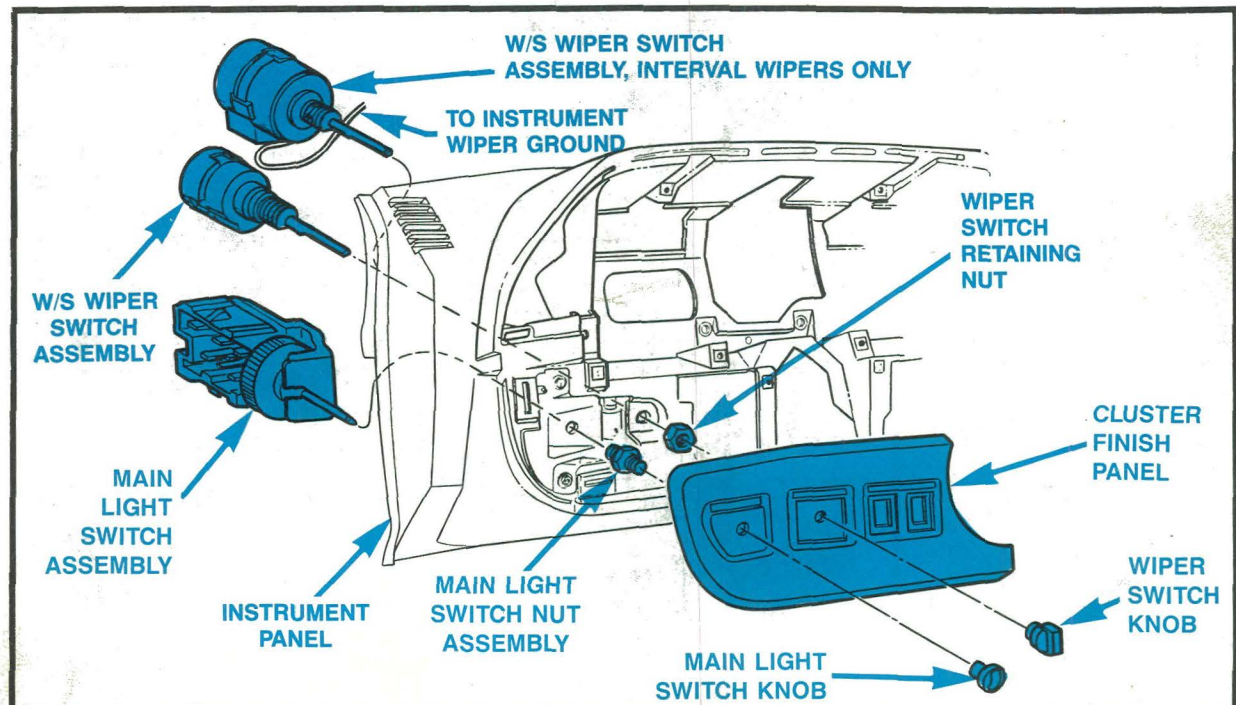
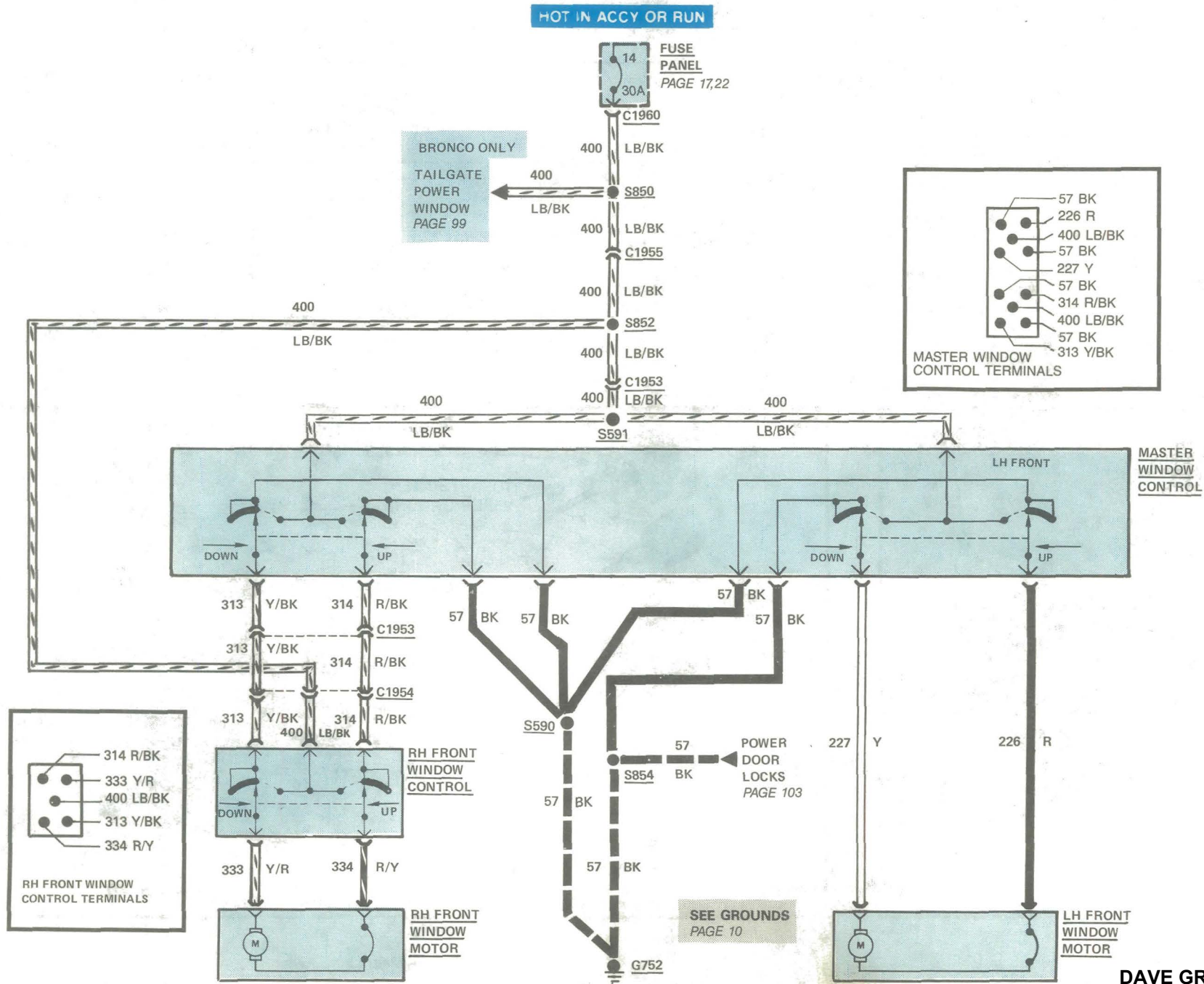

Figure 2 — Main Light Switch



**HOW THE CIRCUIT WORKS**

With the **Ignition Switch** in ACCY or RUN, voltage is applied through **Circuit Breaker 14** to the **Master Window Control** and the **RH Window Control**. These controls control voltage through the **Window Motors** in one direction for UP, and they reverse the current direction for DN.

In the "at rest" position, all switches ground both wires of each motor.

To raise the window, voltage is applied through the UP side of the switch, through the motor, through the motor circuit breaker, and through the DN side of the switch to ground.

To lower the window, voltage is applied in the opposite direction.

Refer to section 42-01 of the shop manual.

**COMPONENT LOCATION**

Master Window Control ..	In LH door .....	98-2
RH Window Control .....	In RH door .....	98-3
Window Motors .....	In respective doors .....	98-1

Page-Figure

Refer to the **Location Index** in the back of the manual for connector, ground, and splice descriptions and locations.

**TROUBLESHOOTING HINTS**

CONDITION	POSSIBLE CAUSE	ACTION
<ul style="list-style-type: none"> <li>No Windows operate</li> </ul>	<ul style="list-style-type: none"> <li>No voltage at LB/BK wire of Window Control</li> <li>Poor ground continuity at BK wires from Master Window Control</li> <li>Frayed or damaged wires or loose connections</li> </ul>	<ul style="list-style-type: none"> <li>Check Circuit Breaker 14 and wiring</li> <li>Clean/Tighten connections and check wires for opens</li> <li>Repair/Replace as required</li> </ul>
<ul style="list-style-type: none"> <li>One Motor doesn't work</li> </ul>	<ul style="list-style-type: none"> <li>If passenger's window motor doesn't work, no voltage at Y/BK or R/BK wires of RH Front Window Control</li> <li>Defective Motor</li> </ul>	<ul style="list-style-type: none"> <li>Repair opens in wires</li> <li>Repair/Replace motor as required</li> </ul>

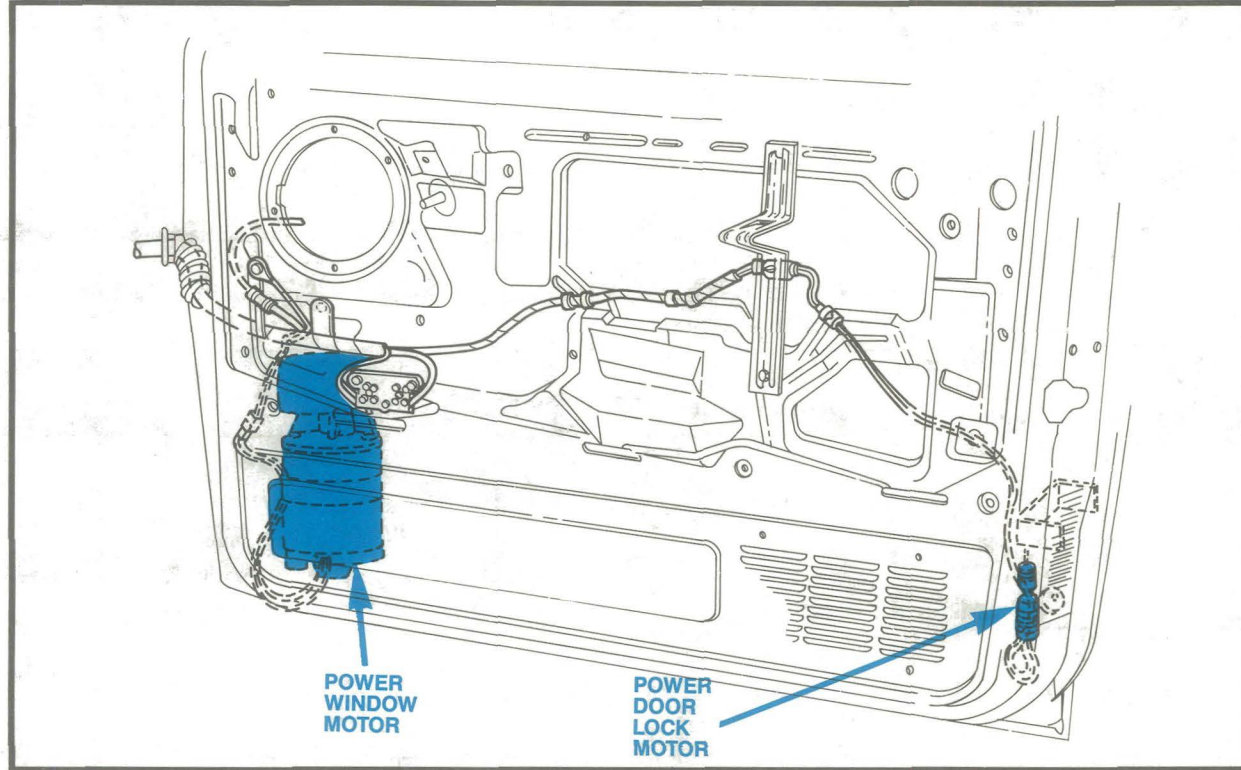

Figure 1 – RH Door

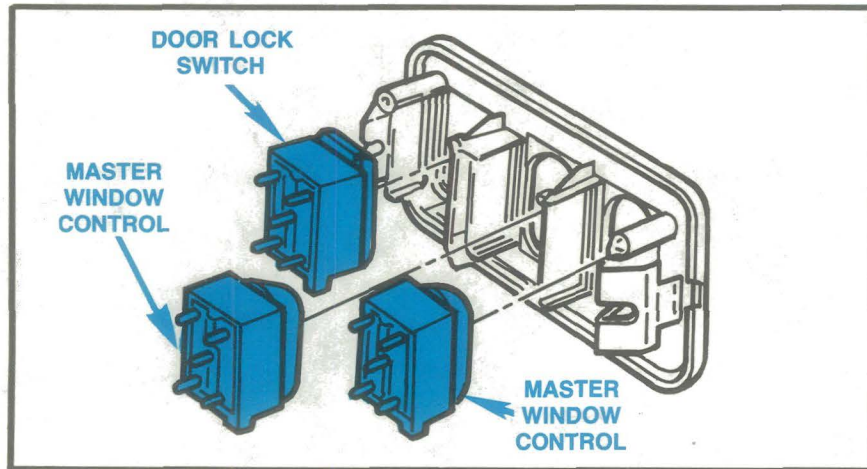

Figure 2 – LH Door

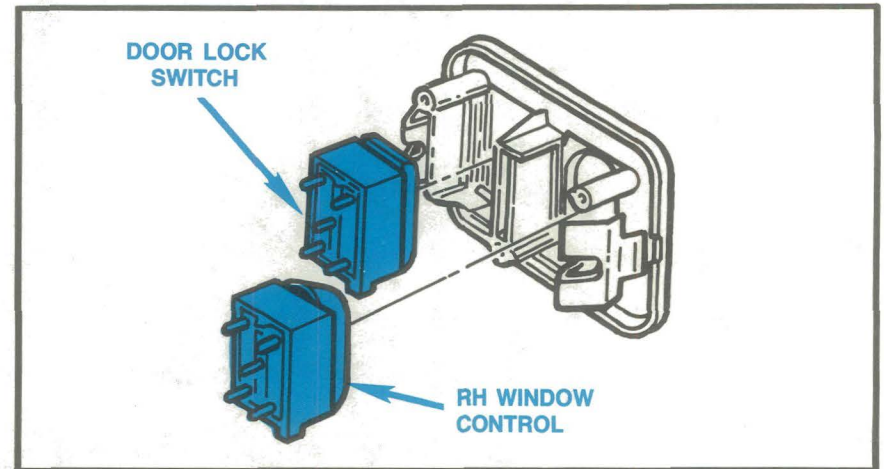
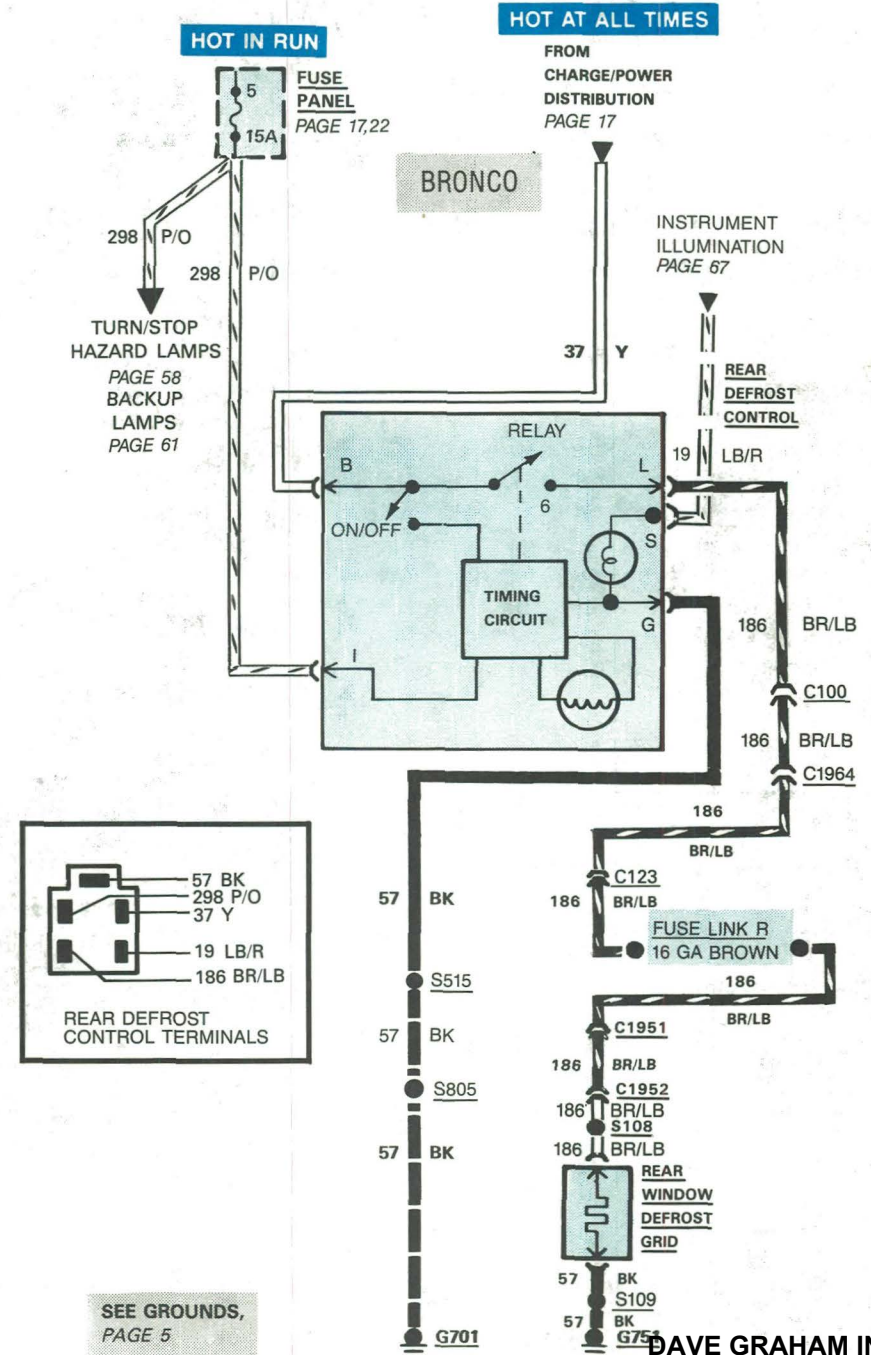
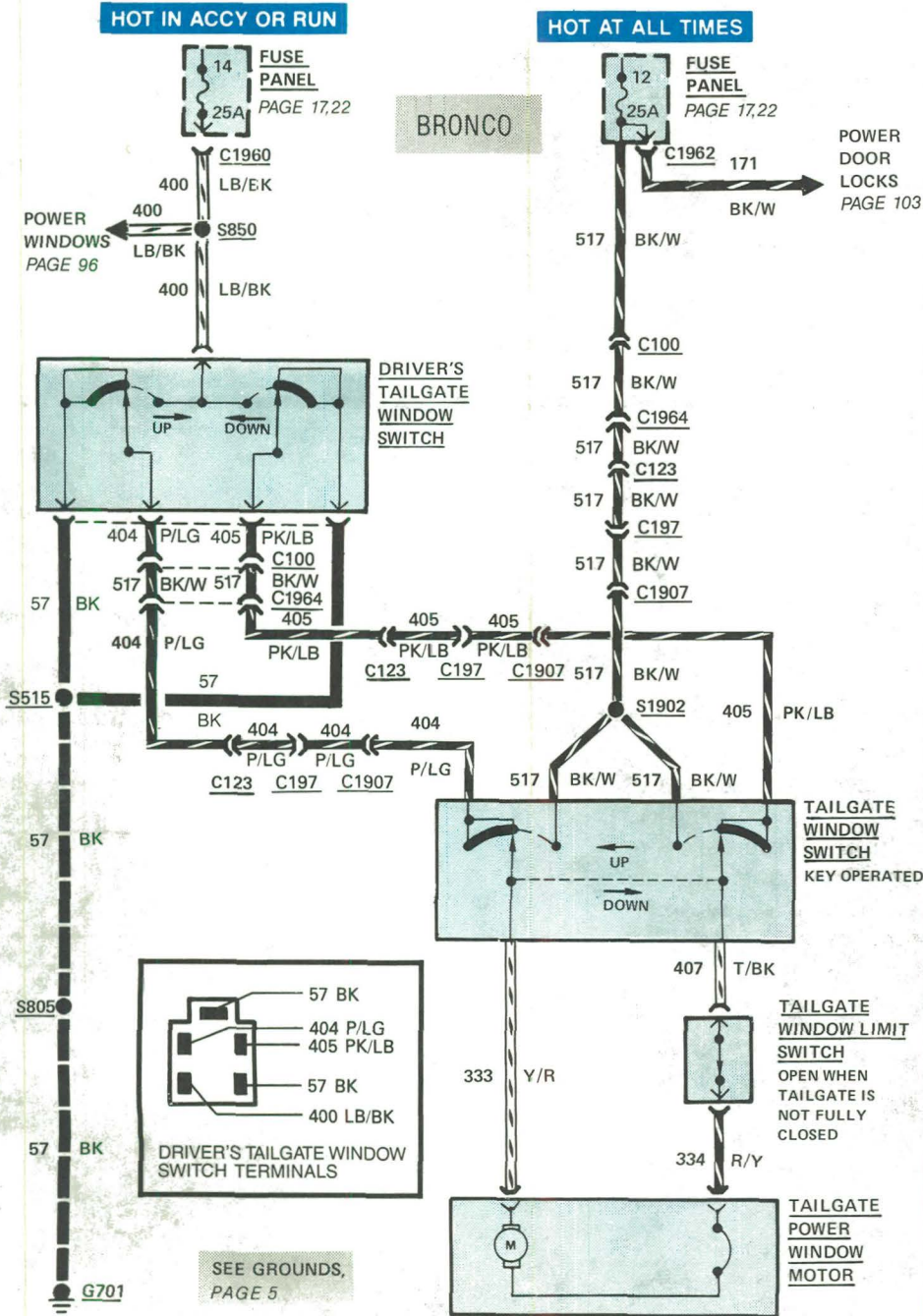

Figure 3 – RH Door



## TAILGATE POWER WINDOW

### HOW THE CIRCUIT WORKS

With **Ignition Switch** in ACCY or RUN, voltage is applied through **Fuse 14** to the **Driver's Tailgate Window Switch** on the instrument panel to run the **Tailgate Power Window Motor**.

The **Tailgate Window Limit Switch** does not allow the motor to run with the tailgate open.

Voltage is applied at all times through **Fuse 12** to the **Key Switch** in the tailgate to run the motor.

Either switch assembly sends current through the motor in one direction for UP, and the opposite direction for DN.

In OFF position, both motor wires are grounded through separate switches.

When the DN switch is pushed, power flows to the DN motor lead. The UP lead acts as ground.

When the UP switch is pushed, power flows to the UP motor lead. The DN lead acts as ground.

Refer to section 42-01 of the shop manual.

### COMPONENT LOCATION

		Page-Figure
Rear Defrost Control	Under LH corner of I/P	101-2
Driver's Tailgate Window Switch	LH side of I/P	101-2
Fuse Link R	LH fender apron	
Tailgate Power Window Motor	In center of tailgate	102-3
Tailgate Window Limit Switch	LH latch	
Key Switch	LH side of tailgate	102-3

Refer to the **Location Index** in the back of the manual for connector, ground, and splice descriptions and locations.

## REAR WINDOW DEFROST

### HOW THE CIRCUIT WORKS

With the **Ignition Switch** in RUN, the **Rear Defrost Control** is powered through **Fuse 5**.

Pressing the momentary defrost switch ON closes the contacts of the defrost relay and starts the ten minute (approximate) timing cycle. Current now flows through **Fuse Link R** to the **Rear Window Defrost Grid**. When the defrost switch is released from ON, the solid-state circuitry keeps the defrost relay coil energized.

Pressing the defrost switch OFF drops out the defrost relay. This removes power from the defrost circuit.

If the OFF switch is not pressed, power will remain on until the time delay runs out. Then the coil will drop out and remove power from the defrost circuit.

Refer to section 36-01 of the shop manual.

## TROUBLESHOOTING HINTS — TAILGATE POWER WINDOW

CONDITION	POSSIBLE CAUSE	ACTION
<ul style="list-style-type: none"> <li>Window works from Key Switch but not from Driver's Switch</li> </ul>	<ul style="list-style-type: none"> <li>No voltage at LB/BK wire of Driver's Switch</li> <li>Defective Driver's Switch</li> <li>Frayed or damaged wires or loose connections</li> </ul>	<ul style="list-style-type: none"> <li>Check Fuse 14 and wiring</li> <li>Replace with known good switch</li> <li>Repair/Replace as required</li> </ul>
<ul style="list-style-type: none"> <li>Window works from Driver's Switch but not from Key Switch</li> </ul>	<ul style="list-style-type: none"> <li>No voltage at BK/W wires of Key Switch</li> <li>Defective Key Switch</li> <li>Frayed or damaged wires or loose connections</li> </ul>	<ul style="list-style-type: none"> <li>Check Fuse 12 and wiring</li> <li>Replace with known good switch</li> <li>Repair/Replace as required</li> </ul>

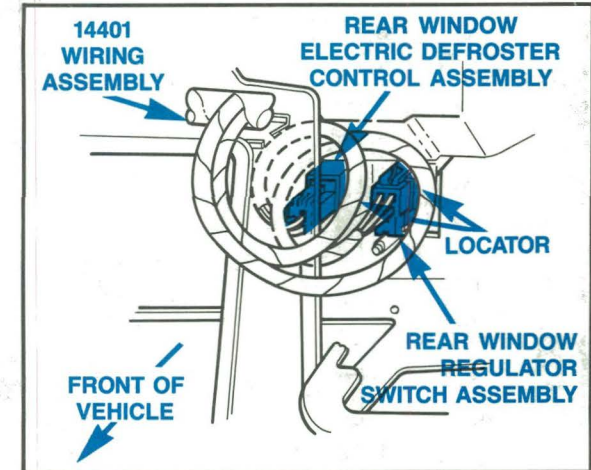

Figure 1 — Rear Window Electric Defrost Control Wiring Installation and Rear Window Regulator Switch Assembly Wiring Installation

## TROUBLESHOOTING HINTS — REAR WINDOW DEFROST

CONDITION	POSSIBLE CAUSE	ACTION
<ul style="list-style-type: none"> <li>Defrost does not operate</li> </ul>	<ul style="list-style-type: none"> <li>No voltage at P/O wire of Defrost Control</li> <li>No voltage at Y wire of Defrost Control</li> <li>No voltage at BR/LB wire of Defrost Grid</li> <li>Defective Defrost Switch Relay</li> </ul>	<ul style="list-style-type: none"> <li>Check Fuse 5 and wiring</li> <li>Check Fuse Link M and wiring</li> <li>Check Fuse Link R and wiring</li> <li>Replace with known good relay</li> </ul>

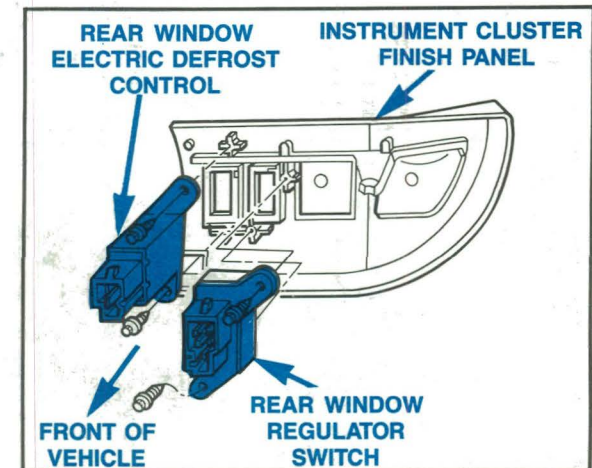

Figure 2 — Rear Window Electric Defrost Control and Rear Window Regulator Switch (Rear View)

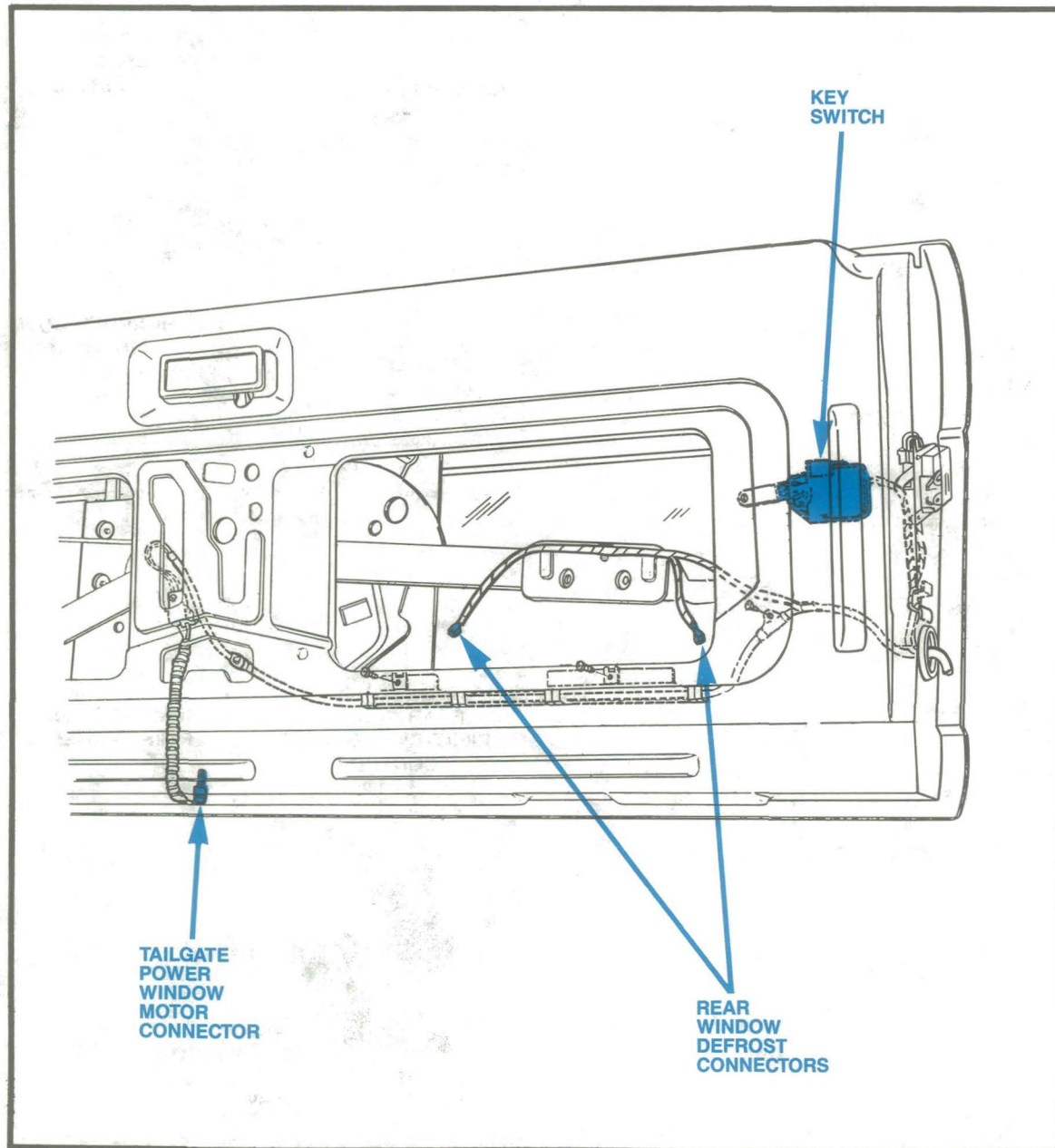

Figure 3—Tailgate (Bronco)

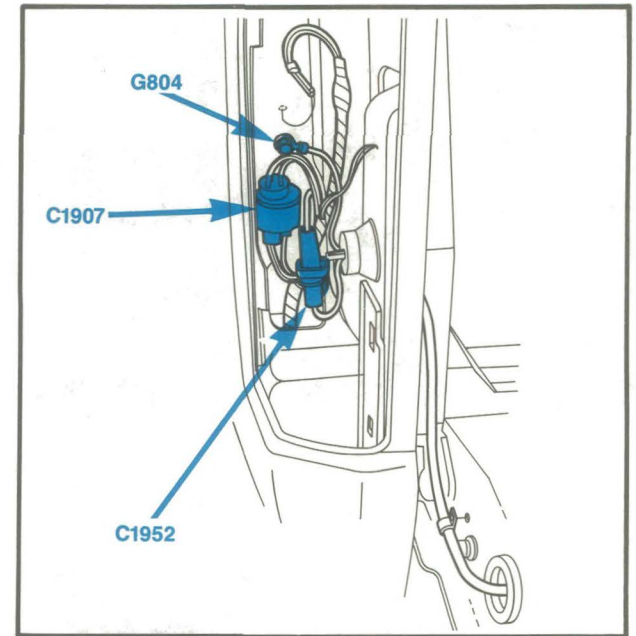

Figure 4—Rear LH Light Assembly

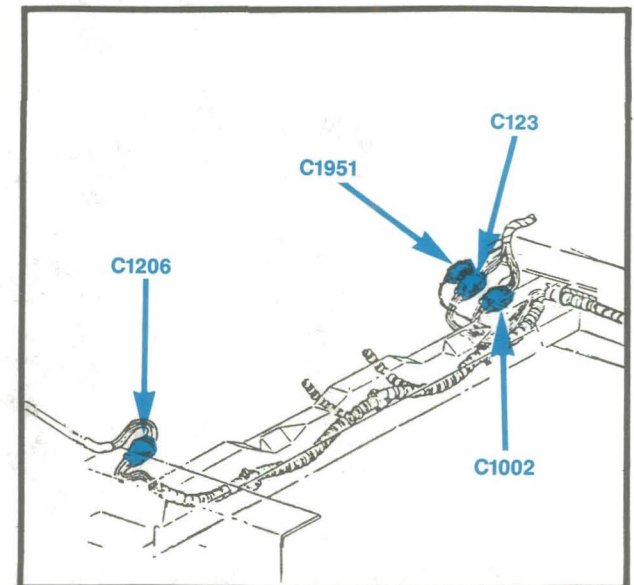
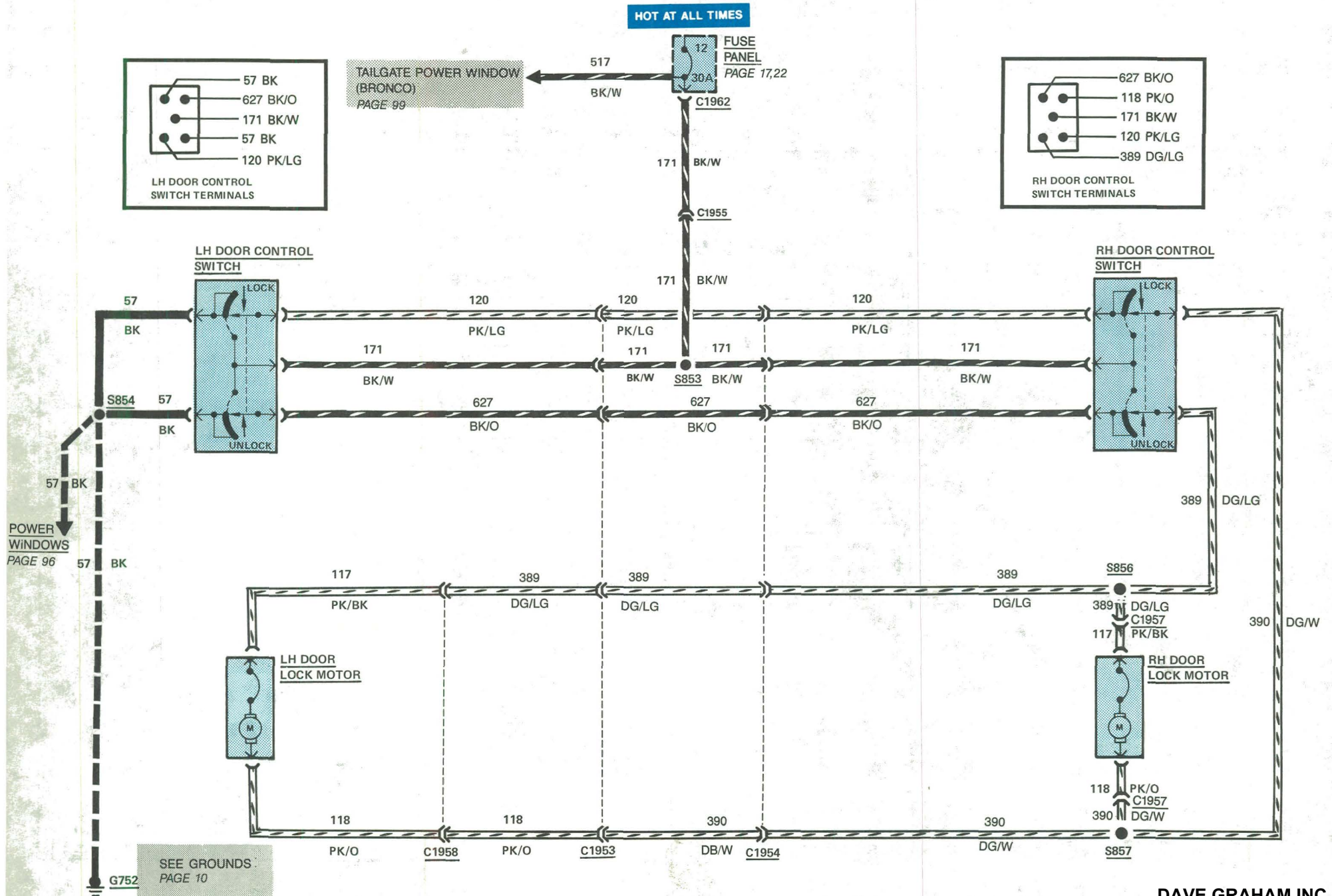

Figure 5—At Rear Crossmember



## HOW THE CIRCUIT WORKS

**Power Door Locks** are powered through **Circuit Breaker 12** (hot at all times).

When either **Door Control Switch** is pressed to **LOCK**, voltage is applied to both **Door Lock Motors**. The motors turn in the direction to lock the locks. When either switch is pressed to **UNLOCK**, voltage of opposite potential is sent to the **Door Lock Motors**, turning them in the **UNLOCK** direction. When "at rest," the switches are grounded.

Refer to section 44-01 of the shop manual.

## COMPONENT LOCATION

Page-  
Figure

Door Lock Motors .....	In respective door .....	98-1
Door Lock Switches .....	In respective doors .....	104-1

Refer to the **Location Index** in the back of the manual for connector, ground, and splice descriptions and locations.

## TROUBLESHOOTING HINTS

CONDITION	POSSIBLE CAUSE	ACTION
<ul style="list-style-type: none"> <li>No Locks work</li> </ul>	<ul style="list-style-type: none"> <li>No voltage at BK/W wire of C1956</li> </ul>	<ul style="list-style-type: none"> <li>Check Circuit Breaker 12 and wiring</li> </ul>
<ul style="list-style-type: none"> <li>One door does not lock (unlock)</li> </ul>	<ul style="list-style-type: none"> <li>Defective Motor</li> <li>Frayed or damaged wiring or loose connections</li> </ul>	<ul style="list-style-type: none"> <li>Repair/Replace with known good motor</li> <li>Repair/Replace as required</li> </ul>
<ul style="list-style-type: none"> <li>One Switch does not work</li> </ul>	<ul style="list-style-type: none"> <li>Frayed or damaged wiring or loose connections</li> <li>Defective Switch</li> </ul>	<ul style="list-style-type: none"> <li>Repair/Replace as required</li> <li>Replace with known good switch</li> </ul>

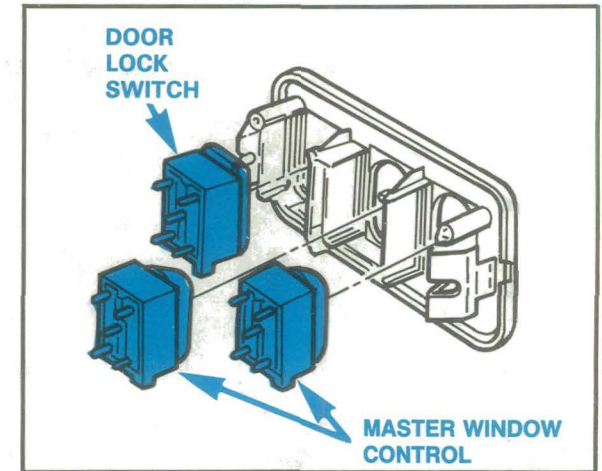

Figure 1 — LH Door  
DAVE GRAHAM INC. - 2012  
ALL RIGHTS RESERVED

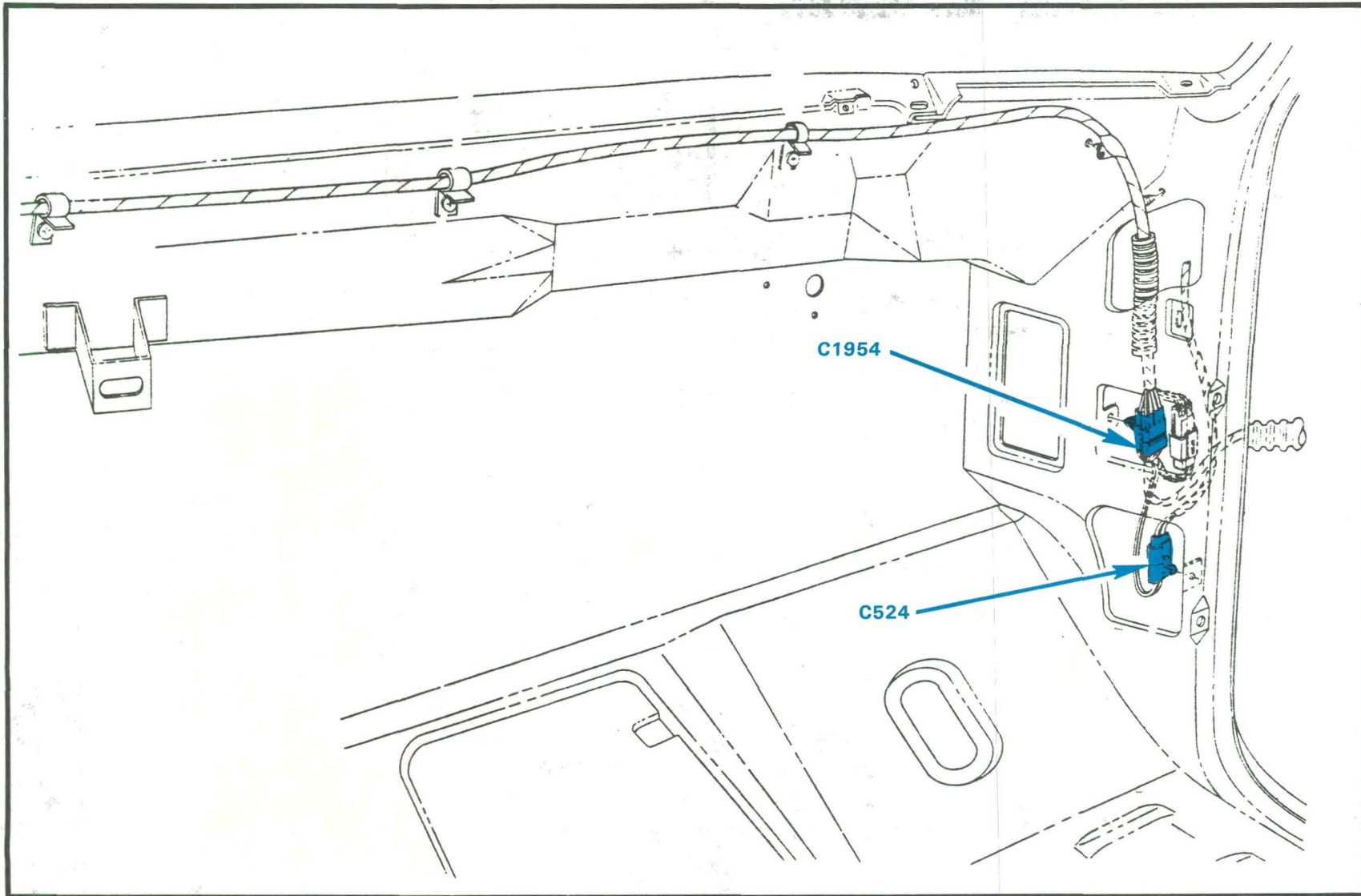
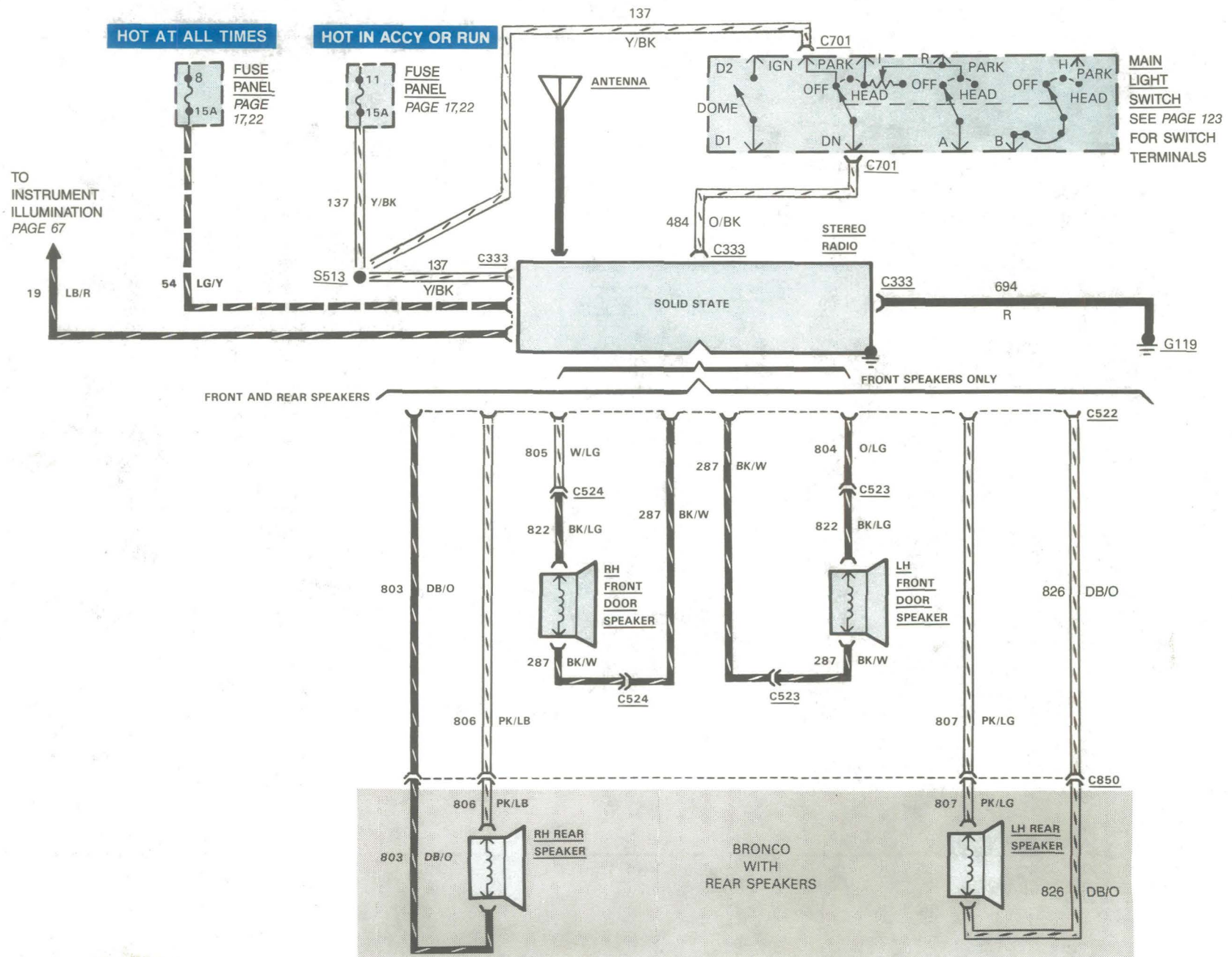

Figure 3 — RH Cowl Center Access Hole

# 106 RADIO (STEREO) (ELECTRONIC)



## HOW THE CIRCUIT WORKS

With the **Ignition Switch** in ACCY or RUN, voltage is applied through **Fuse 11** to operate the radio. Circuit number 54 powers the Radio Memory. Circuit number 484 powers the LCD Radio Lighting.

### Stereo Radio

The AM/FM/MPX **Stereo Radio** has two **Front Door Speakers** and two optional **Rear Speakers** (Bronco only).

Refer to section 35-01 of the shop manual.

## COMPONENT LOCATION

Page-  
Figure

Main Light Switch .....	Lower I/P, left of steering column .....	95-2
Radio .....	Center of I/P .....	

Refer to the **Location Index** in the back of the manual for connector, ground, and splice descriptions and locations.

## TROUBLESHOOTING HINTS

CONDITION	POSSIBLE CAUSE	ACTION
• Radio does not work	• No voltage at Y/BK wire of Radio	• Check Fuse 11 and wiring
• Radio memory, Display and Clock do not work	• No voltage at LG/Y wire of Radio	• Check Fuse 8 and wiring

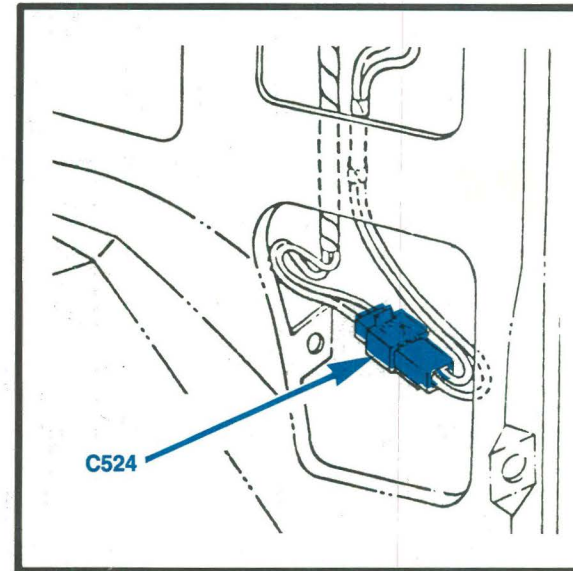
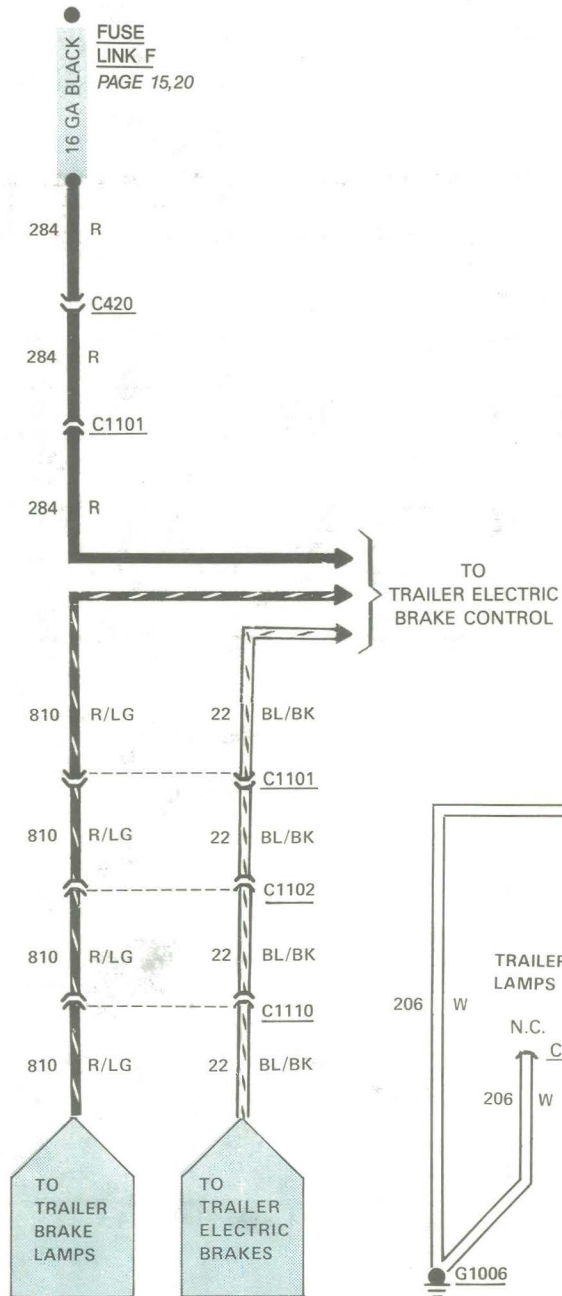

Figure 1 – RH Lower Shroud Access Hole

# 108 TRAILER OPTION

HOT AT ALL TIMES



HOT AT ALL TIMES

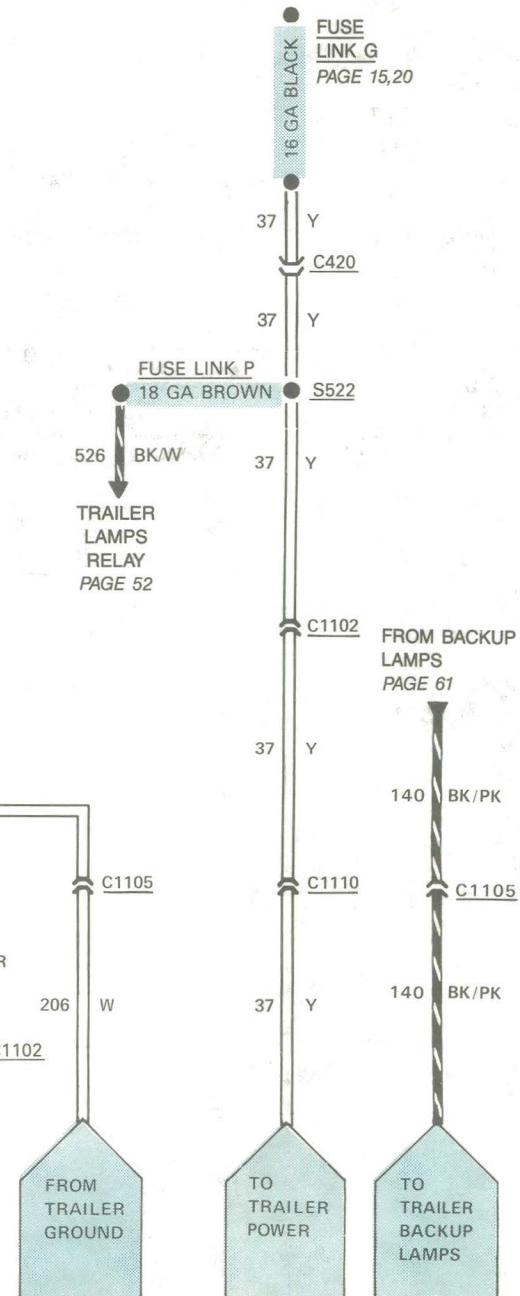

**HOW THE CIRCUIT WORKS**

Power for the **Camper** or **Trailer** circuits is provided through fuse links at the **Starter Relay**. Trailer exterior lamps and accessories are powered through **Fuse Link G**. Trailer brakes and brake lamps are powered through **Fuse Link F**.

Refer to section 32-01 of the shop manual.

**COMPONENT LOCATION**

Page-  
Figure

Fuse Link F, G ..... At starter relay .....  
 Fuse Link P ..... Near trailer lamps relay — LH fender apron .....

Refer to the **Location Index** in the back of the manual for connector, ground, and splice descriptions and locations.

**TROUBLESHOOTING HINTS**

CONDITION	POSSIBLE CAUSE	ACTION
<ul style="list-style-type: none"> <li>Trailer Lamps don't light</li> </ul>	<ul style="list-style-type: none"> <li>No voltage at R or Y wires of circuit</li> <li>Poor in-line circuit connections</li> </ul>	<ul style="list-style-type: none"> <li>Check Fuse Links F and G and wiring</li> <li>Clean/Tighten and/or repair open in wiring</li> </ul>

# 110 VACUUM SYMBOLS

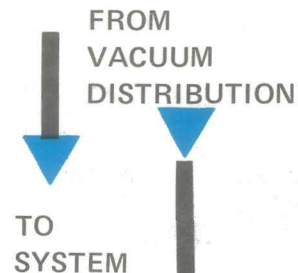
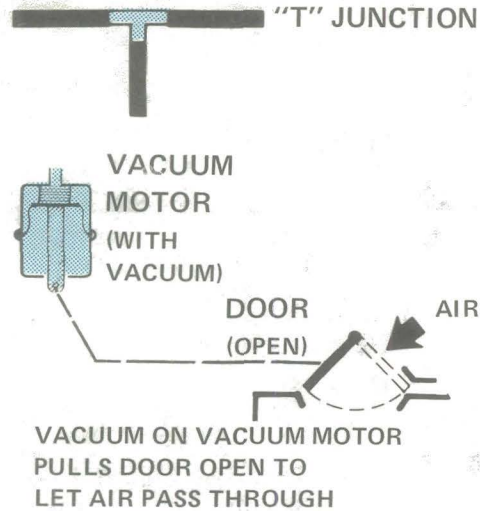

"CUT" HOSES REFERENCED BETWEEN PAGES  
ARROW SHOWS VACUUM FLOW FROM MANIFOLD FITTING TO COMPONENT

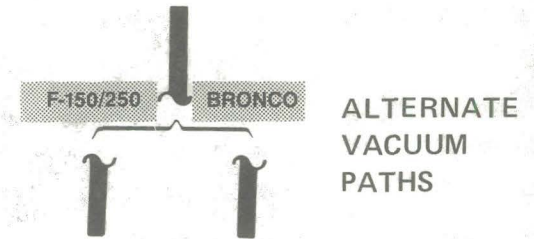

NOTE  
Other vacuum symbols used on vacuum system diagrams are fully explained on those pages.

## VACUUM MOTOR OPERATIONS

### SINGLE DIAPHRAGM MOTOR

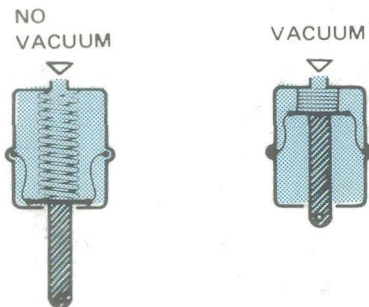

Vacuum motors operate like electrical solenoids, mechanically pushing or pulling a shaft between two fixed positions. When vacuum is applied, the shaft is pulled in. When no vacuum is applied, the shaft is pushed all the way out by a spring.

### SERVO MOTOR

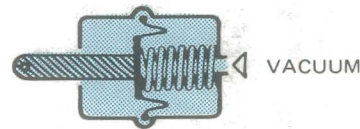

Some vacuum motors such as the **Servo Motor** in the **Speed Control** can position the actuating arm at any position between fully extended and fully retracted. The **Servo** is operated by a control valve that applies varying amounts of vacuum to the motor. The higher the vacuum level, the greater retraction of the motor arm. **Servo** motors work exactly the same as the two-position motors; the only difference is in the way the vacuum is applied. **Servo Motors** are generally larger and provide a calibrated control.

### DOUBLE DIAPHRAGM MOTOR

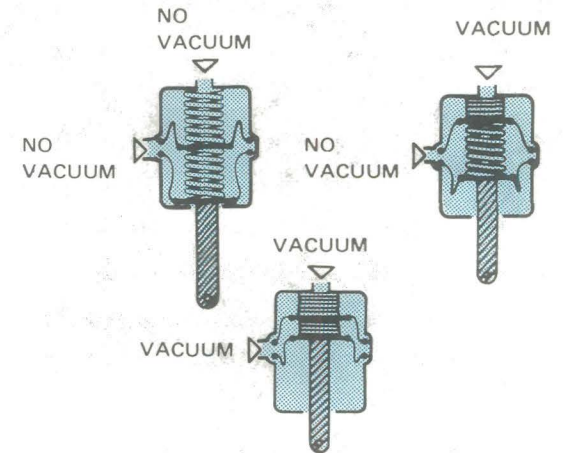

A double diaphragm motor has three positions and is really two motors in one housing. When the top port gets vacuum, the shaft pulls half-way in. When both ports get vacuum, the shaft pulls all the way in.

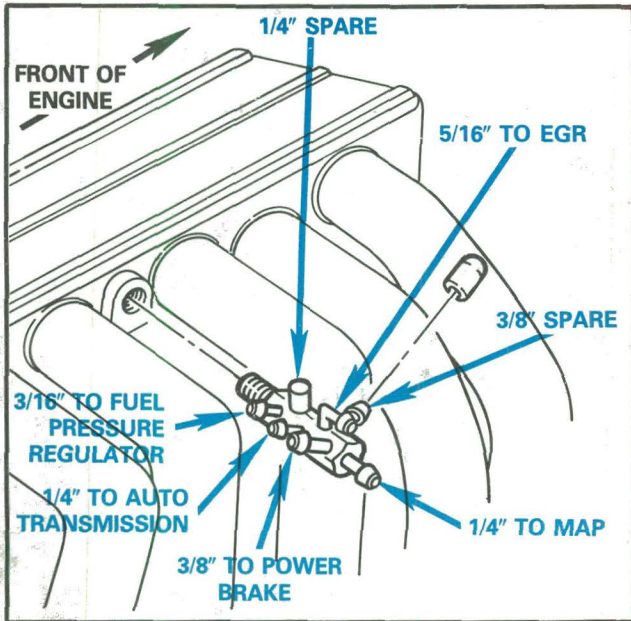

Figure 1 - 4.9L

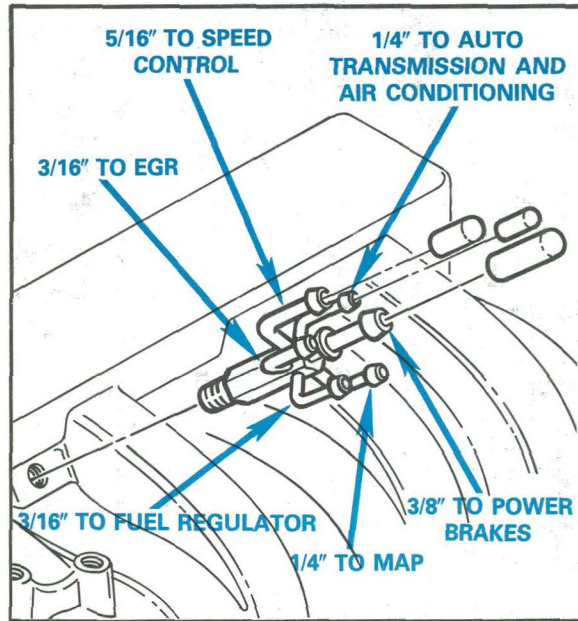

Figure 2 - 5.0L

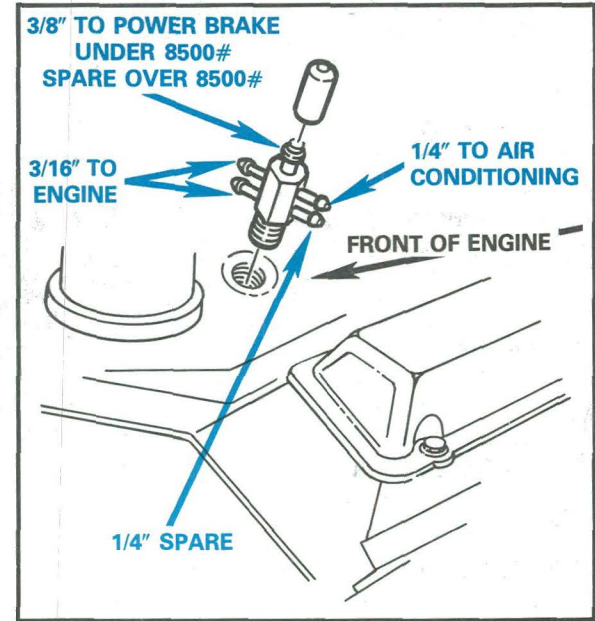

Figure 3 - 5.8L Front Fitting

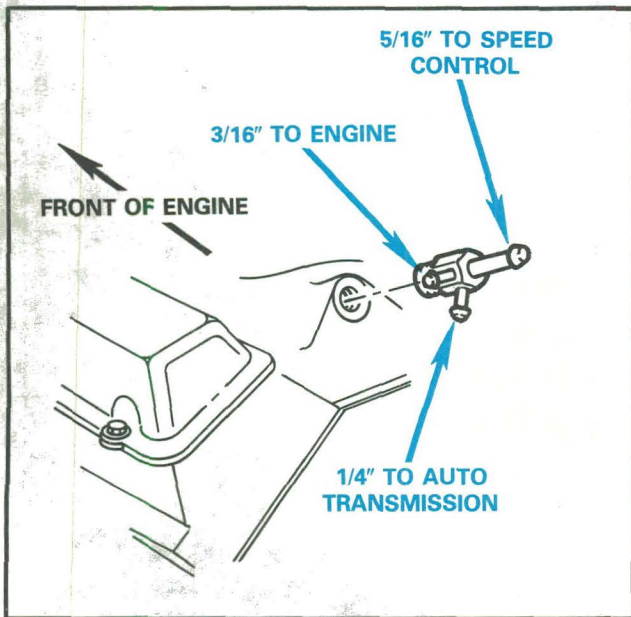

Figure 4 - 5.8L Under 8500# Rear Fitting

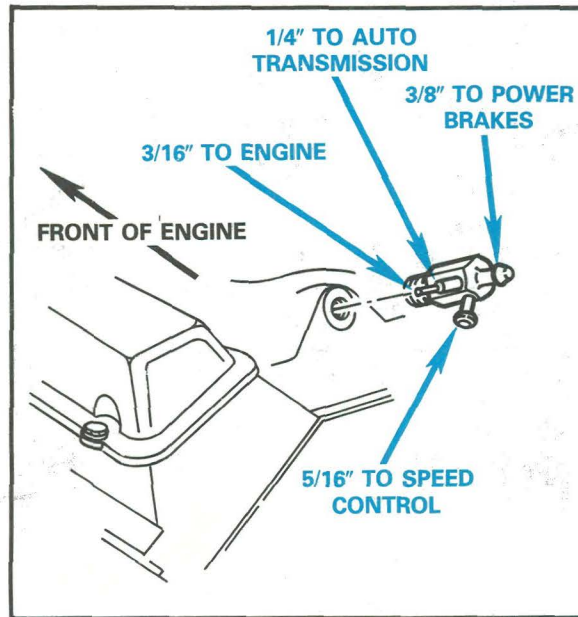

Figure 5 - 5.8L Over 8500# Rear Fitting

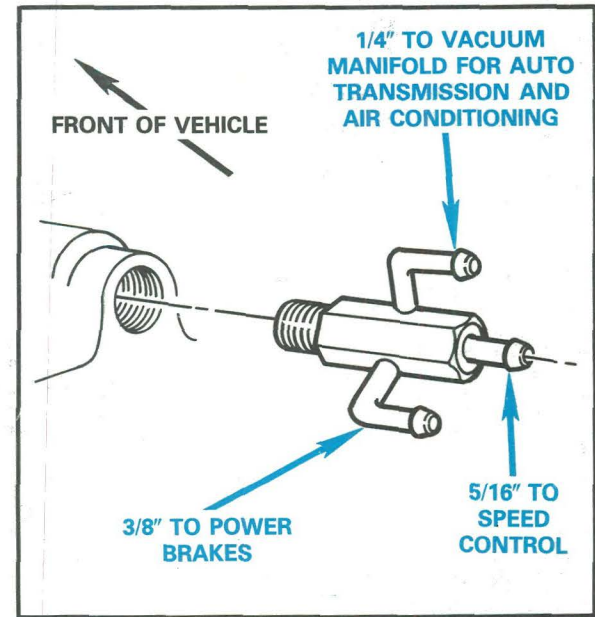

Figure 6 - 7.5L

## TROUBLESHOOTING STEPS

These six steps present an orderly method of troubleshooting:

### Step 1. Verify the problem.

- Operate the complete system and see all symptoms for yourself in order to:
  - check the accuracy and completeness of the customer's complaint.
  - learn more that might give a clue to the nature and location of the problem.

### Step 2. Narrow the problem.

- Using the EVTm, narrow down the possible causes and locations of the problem in order to more quickly find the exact cause.

### Step 3. Test the cause.

- Use test procedures to find the specific cause of the symptoms.

### Step 4. Verify the cause.

- Confirm the fact that you have found the correct cause through operating the parts of the circuit you think are good.

### Step 5. Make the repair.

- Repair or replace the faulty component.

### Step 6. Verify the repair.

- Operate the system as in Step 1 and check that your repair has removed all symptoms, and also has not caused any new symptoms.

## TROUBLESHOOTING TESTS

### NOTE

Vacuum system problems fall into three groups:

1. Leaks in hoses, connectors, or motor diaphragms.
2. Pinched Lines or Clogged Valves.
3. Faulty mechanical operation of parts driven by vacuum motors.

## Vacuum Supply Test

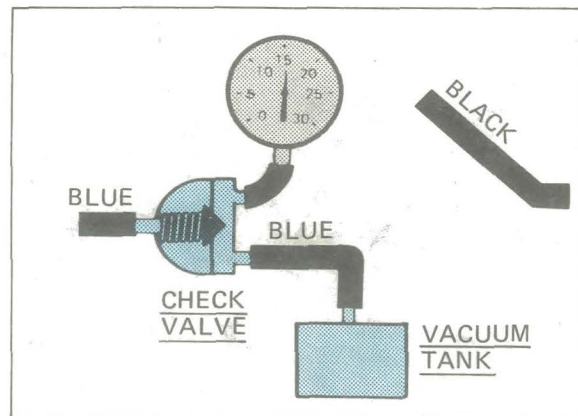

Figure 1 — System Supply Test

1. Connect **Vacuum Tester** to system side of **Check Valve** (Figure 1).
2. Start engine. Gage should show approximately 15" of vacuum.
3. Turn off engine. Watch gage.
  - If vacuum holds, supply OK.
  - If vacuum fails, replace **Check Valve** or **Tank**.

## Leak Test

1. Connect **Vacuum Gage** and **Vacuum Pump** (Figure 3) to system hose in place of tank.
2. Open valve and start pump. Operate controls in all modes.
3. Listen for hiss, watch gage.

### NOTE

Hissing is normal at **Function Control** when changing modes.

If system hisses or loses vacuum, find system leak as follows:

1. Turn on **Vacuum Pump** and check for vacuum build-up.

2. Stop pump, vacuum should drop due to leak.
3. Clamp supply hoses with needle-nose pliers one at a time until vacuum stops dropping (Figure 3).
4. Check vacuum schematic to find components in that line.
5. Clamp hoses through circuit to find leak.

## Component Test

1. Connect **Vacuum Tester** (Figure 2) to component.
2. Pump **Vacuum Tester** and check that component operates correctly and vacuum holds.
3. Replace component if vacuum doesn't hold.

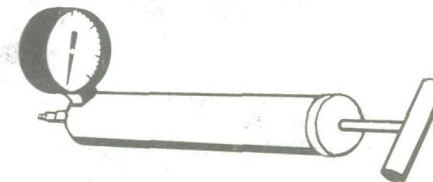

Figure 2 — Vacuum Tester

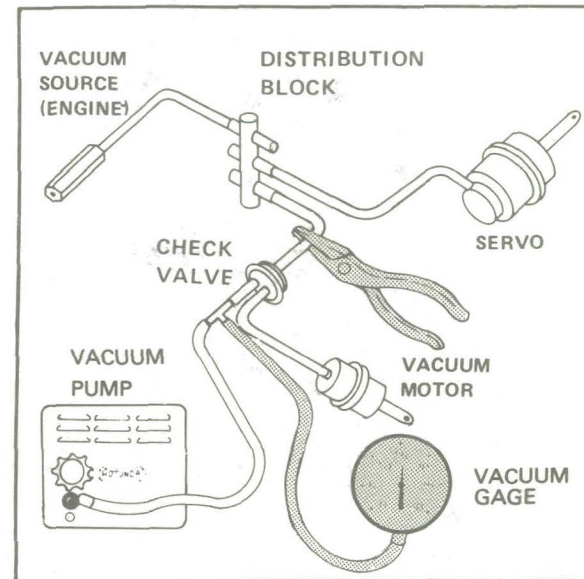
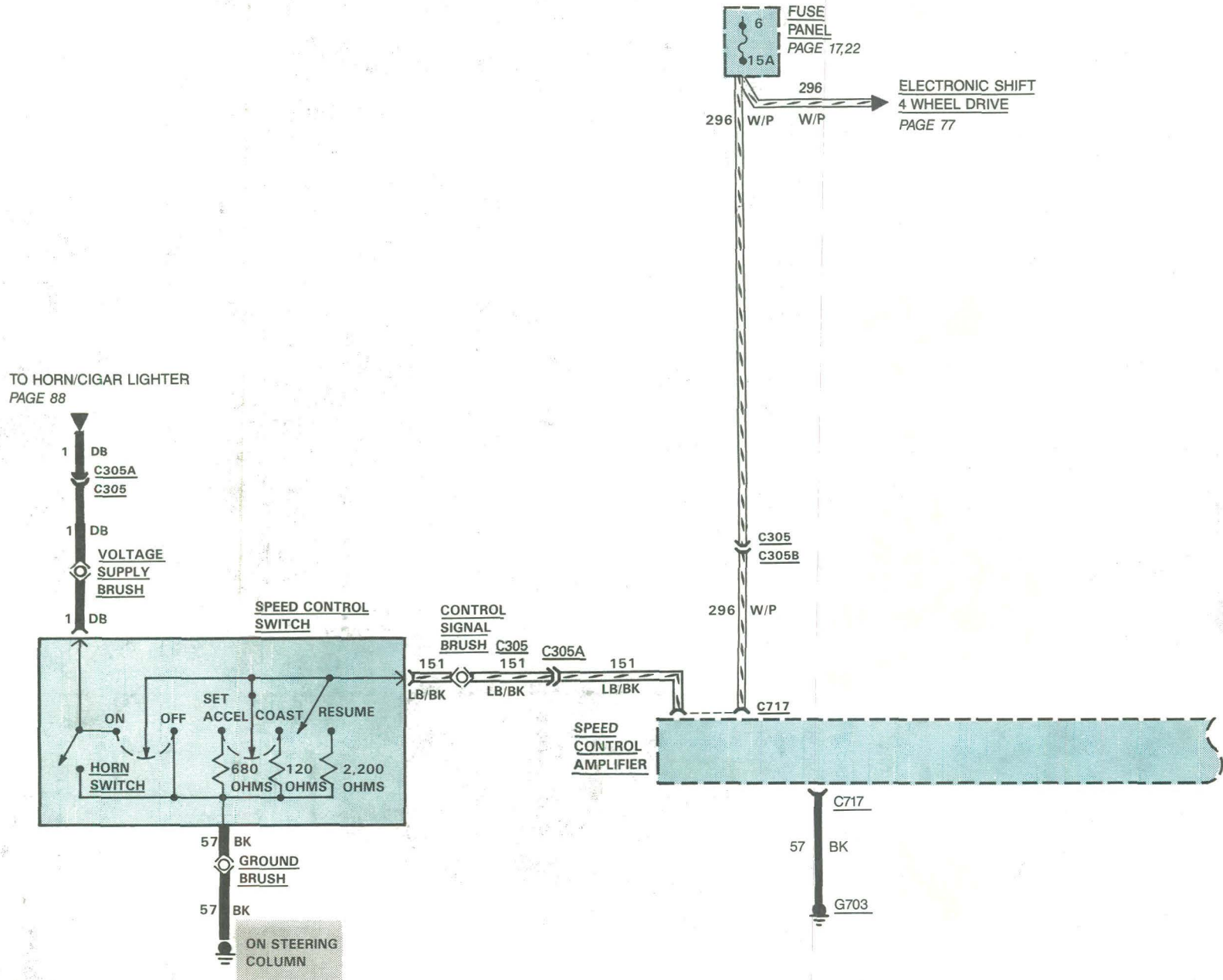

Figure 3 — Testing For Leak In Typical Vacuum System





**HOW THE CIRCUIT WORKS**

The **Speed Control Amplifier** controls vacuum to the **Speed Control Servo** motor through the modulating valve. The servo motor moves the throttle through the **Actuator** (cable or bead chain).

To operate the **Speed Control System**, the engine must be running and the car speed faster than 30 mph. The system is turned on by pressing the ON switch of the **Speed Control Switch**.

Pressing and releasing SET/ACCEL or COAST sends a command to hold the present speed. This speed is now the *set speed*. The **Speed Sensor** (in the transmission) sends signals to the **Speed Control Amplifier**. These signals tell the amplifier to increase or decrease the vacuum at the servo motor to keep the truck at the *set speed*.

Pressing and holding SET/ACCEL speeds the truck up. The truck speed increases as long as SET/ACCEL is depressed. Releasing SET/ACCEL gives the system a new *set speed* to maintain. Truck speed may also be increased by depressing the accelerator until the higher speed is reached, then pressing and releasing SET/ACCEL.

Pressing and holding COAST slows the truck down. The truck speed decreases as long as COAST is depressed. Releasing COAST gives the system a new *set speed* to maintain.

Pressing OFF turns the system off (grounds LB/BK wire). The system is also turned off when the brake pedal is depressed (power through LG/R wire) or the **Ignition Switch** is turned OFF. The **Vacuum Dump Valve** also operates when the brake pedal is depressed. This is a backup device to turn off the system. In trucks with manual transmission, the **Clutch Switch** opens when the clutch pedal is depressed and turns off the system.

**COMPONENT LOCATION**

Page-Figure

Hazard Flasher .....	On back of fuse panel .....	
Clutch Switch .....	Attached to bracket at top of clutch pedal .....	
Horn Switch .....	Mounted in steering wheel hub assembly .....	
Speed Control Amplifier ..	Behind I/P at RH side of steering column .....	90-2
Speed Control Servo ....	On LH inner fender next to master brake cylinder .....	
Speed Control Switch ....	Mounted in steering wheel hub assembly .....	
Speed Sensor .....	On transmission .....	
Stop Lamp Switch .....	Mounted to bracket at top of brake pedal .....	

Refer to the **Location Index** in the back of the manual for connector, ground, and splice descriptions and locations.

**TROUBLESHOOTING HINTS**

CONDITION	POSSIBLE CAUSE	ACTION
<ul style="list-style-type: none"> <li>Speed Control does not operate</li> </ul>	<ul style="list-style-type: none"> <li>No voltage at W/P wire of Speed Control Amplifier</li> <li>Poor ground connection at BK wire of Speed Control Amplifier</li> <li>Open wires and/or damaged hoses</li> <li>Actuator cable has more than 1/8 inch free play</li> <li>Speed Control Servo binding</li> <li>Throttle linkage binding</li> </ul>	<ul style="list-style-type: none"> <li>Check Fuse 6 and wiring</li> <li>Clean/Tighten connection and check for open in wiring</li> <li>Repair/Replace as required</li> <li>Adjust as required</li> <li>Repair as required</li> <li>Repair as required</li> </ul>

When the system has been deactivated by depressing the brake or clutch pedal, the last *set speed* may be resumed by pressing RESUME. This feature will not work if OFF has been depressed or if truck speed is below 30 mph.

Refer to section 37-01 of the shop manual.

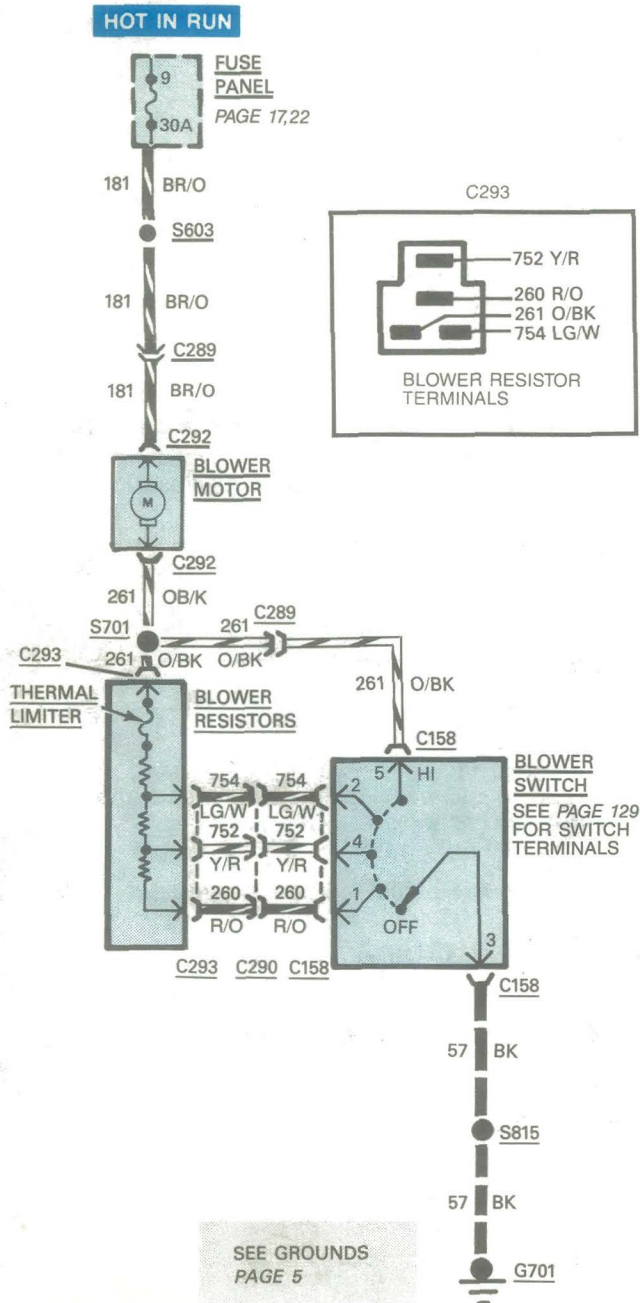

## COMPONENT LOCATION

Blower Motor	Mounted to heater housing at RH side of dash panel in engine compartment	
Blower Resistors	Mounted to heater housing next to blower motor in engine compartment	120-1
Blower Switch	At center of I/P	

Refer to the **Location Index** in the back of the manual for connector, ground, and splice descriptions and locations.

## TROUBLESHOOTING HINTS

CONDITION	POSSIBLE CAUSE	ACTION
<ul style="list-style-type: none"> <li>Blower does not work</li> </ul>	<ul style="list-style-type: none"> <li>No voltage at Blower Motor</li> <li>Poor continuity to ground from BK wire</li> <li>Defective Blower Motor</li> <li>Open Blower Resistors</li> <li>Defective Blower Switch</li> </ul>	<ul style="list-style-type: none"> <li>Check Fuse 9 and wiring</li> <li>Clean/Tighten connection and check wiring for opens</li> <li>Replace with known good motor</li> <li>Replace as required</li> <li>Replace with known good switch</li> </ul>

## HOW THE CIRCUIT WORKS

With the Ignition Switch in RUN and the Blower Switch in LO, MED 1, MED 2, or HI, voltage is applied through Fuse 9, the Blower Motor, the Blower Resistors, and the Blower Switch to G701.

In LO, MED 1, or MED 2, voltage is applied through one, two or all Blower Resistors. In HI, voltage is applied directly from the Blower Motor through the switch to ground.

Refer to section 36-01 of the shop manual.

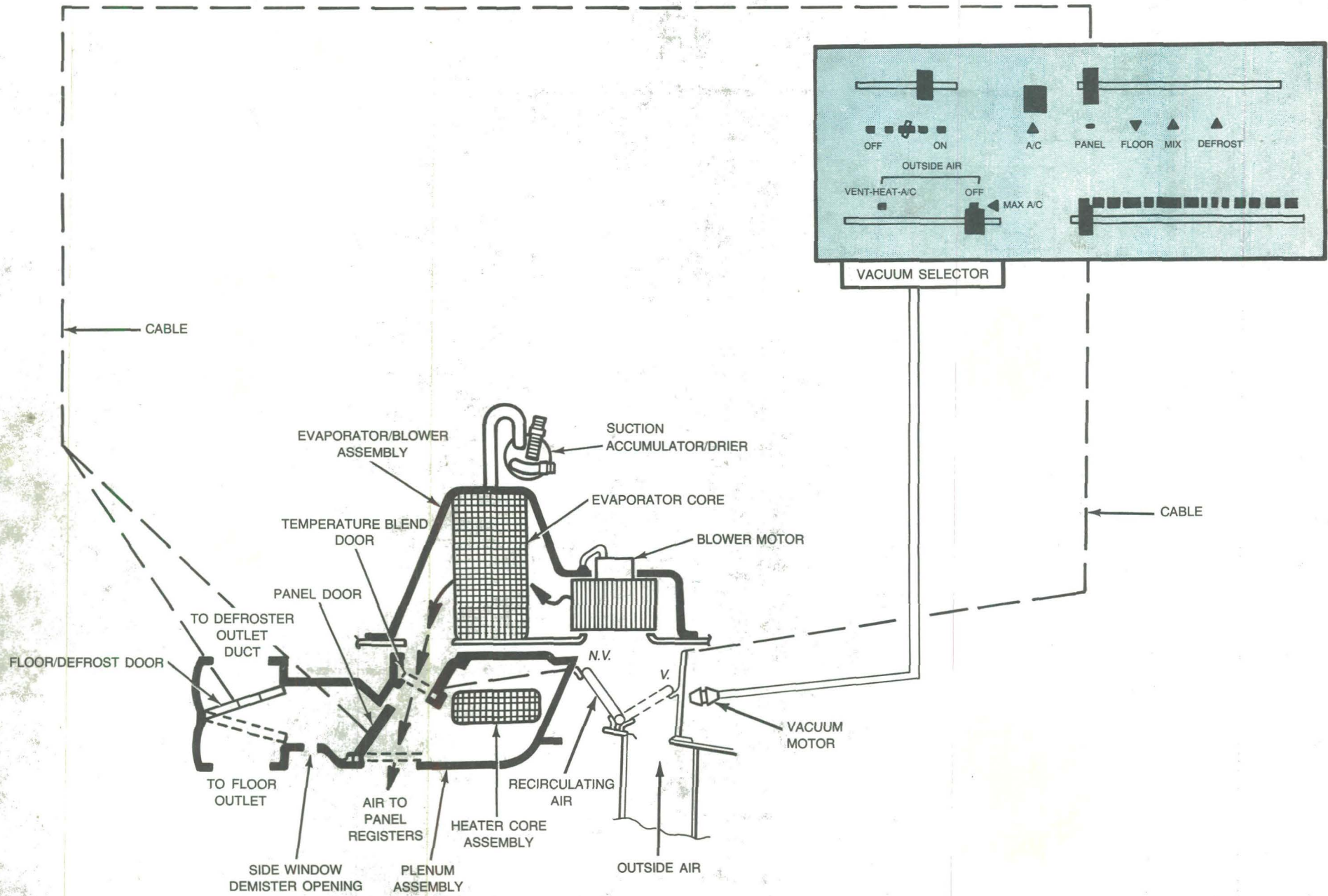

# 118 A/C-HEATER (ELECTRICAL)

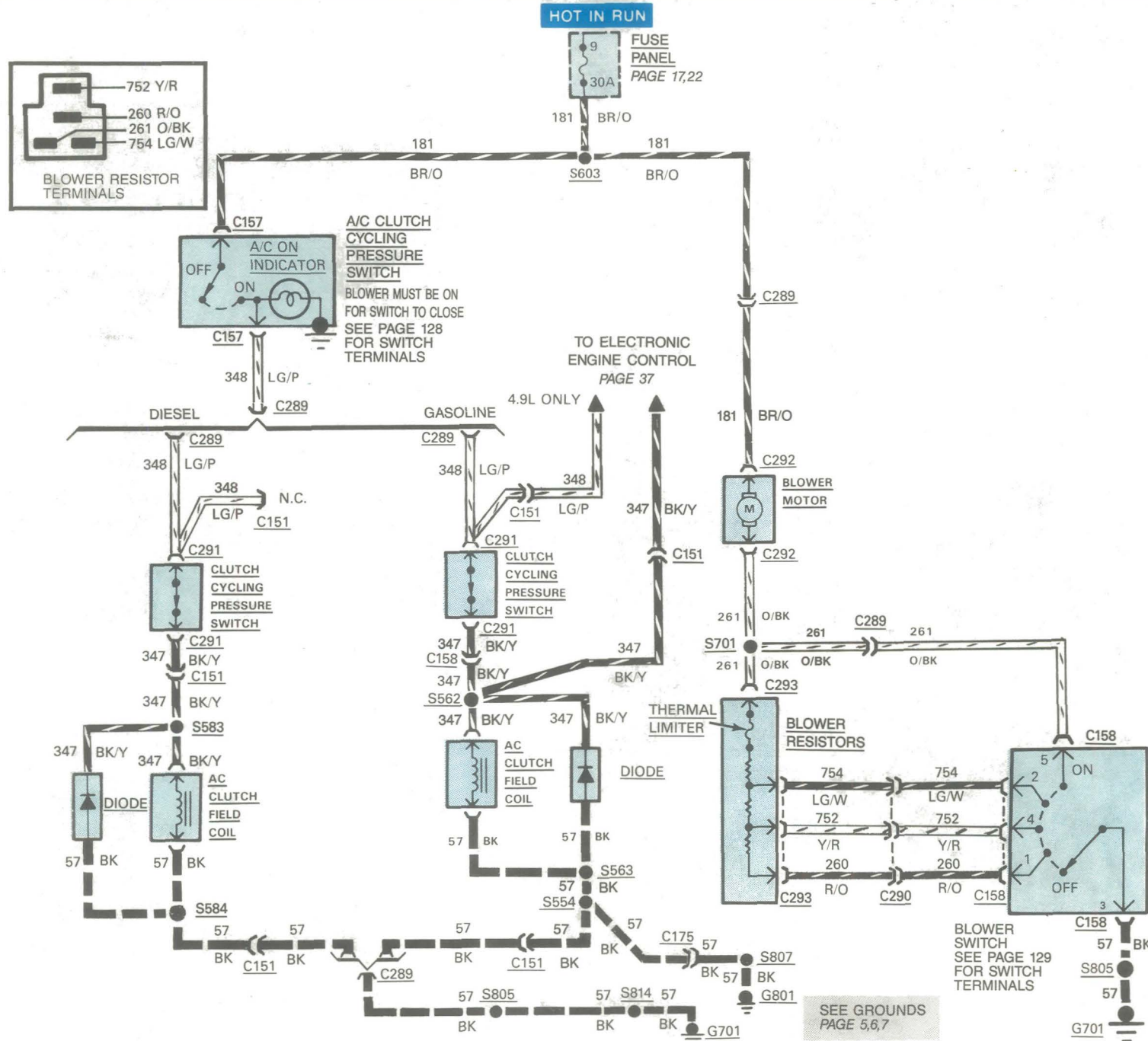

**HOW THE CIRCUIT WORKS**

**Blower**

The **Blower** circuit is used in both the Heater and A/C-Heater systems.

With the **Ignition Switch** in RUN, voltage is applied to the **Blower Motor**. With the **Blower Switch** in HI position, ground is connected to the motor for full speed operation. In OFF there is no ground connection to the motor. In the intermediate positions, one, two, or three resistors and a thermal limiter are connected between the motor and ground to control current and motor speed.

**Control Assembly**

The Heater Control assembly contains the **Blower Switch** and three control levers. The four-position Function Selector Lever (labeled **Panel, Hi-Lo, Floor and Defrost**) controls output air to the floor, instrument panel, and defrost outlets. The outside door lever, labled Vent-Heat and Off, opens (**Vent-Heat**) and closes the system to outside air.

The temperature control lever moves a control cable connected to the temperature blend air door which directs air flow through and/or around the heater core.

**A/C-Heater**

The A/C-Heater system contains a control assembly (on the instrument panel), an evaporator blower housing assembly, a plenum assembly and air distribution ducts, and a condenser and compressor (in the engine compartment).

**COMPONENT LOCATION**

Page-  
Figure

A/C Clutch Switch .....	In center of I/P .....	
A/C Clutch Field Coil .....	Part of Compressor .....	120-2
Blower Motor .....	Mounted to evaporator at RH side of dash panel in engine compartment .....	
Blower Switch .....	At center of I/P .....	
Blower Resistors .....	Mounted to evaporator next to blower .....	120-1
Clutch Cycling Pressure Switch .....	RH side of dash panel on accumulator .....	

Refer to the **Location Index** in the back of the manual for connector, ground, and splice descriptions and locations.

The A/C Heater Control assembly contains the **Blower Switch** and the pushbutton **A/C Clutch Switch**. The **A/C Clutch Switch** applies voltage to the **A/C Clutch Field Coil** circuit which allows the engine to drive the compressor when the pressure switch is closed. The **Vacuum Control Solenoid** increases idle speed when the **A/C Clutch Field Coil** is energized. The **Clutch Cycling Pressure Switch** cuts off power to the **A/C Clutch Field Coil** with low suction pressure to prevent evaporator freeze-up.

Other controls on the A/C Heater control assembly move cables which adjust doors in the air system. The four-position function selector lever (labeled **Panel, Hi-Lo, Floor, and Defrost**) controls output air to the floor, instrument panel, and defrost outlets.

The air door lever, labeled **Vent, Heat, A/C, Max A/C**, selects inlet air from outside the car (**Vent, Heat, A/C**), or recirculated in-car air (**Max A/C**).

The temperature control lever moves a control cable connected to the temperature blend air door which directs air through and/or around the heater core to obtain the desired discharge air temperature.

Refer to section 36-01 of the shop manual.

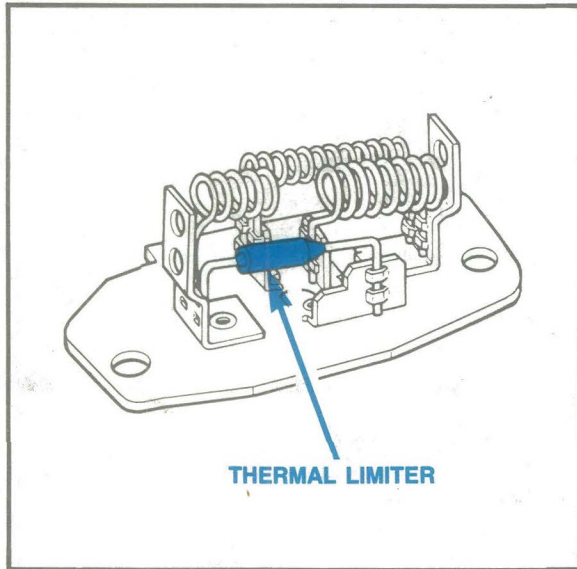

Figure 1 — Blower Resistor Assembly

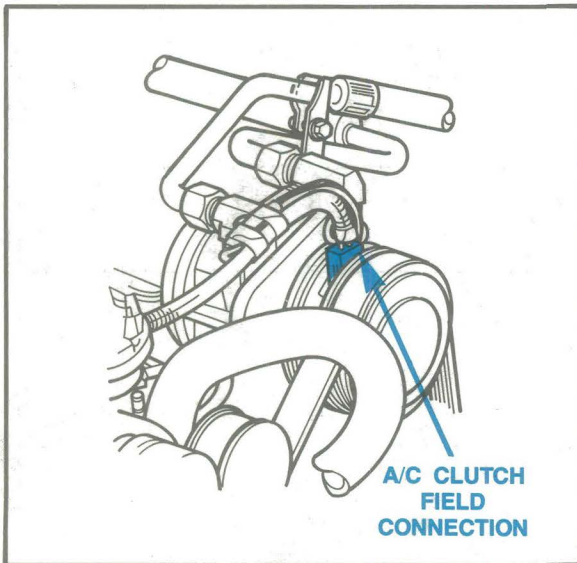

Figure 2 — Air Conditioning Compressor Field Coil

## TROUBLESHOOTING HINTS

CONDITION	POSSIBLE CAUSE	ACTION
<ul style="list-style-type: none"> <li>Blower does not work</li> </ul>	<ul style="list-style-type: none"> <li>No voltage at Blower Motor</li> <li>Poor continuity to ground from BK wire</li> <li>Defective Blower Motor</li> <li>Open Blower Resistors</li> <li>Defective Blower Switch</li> </ul>	<ul style="list-style-type: none"> <li>Check Fuse 9 and wiring</li> <li>Clean/Tighten connection and check wiring for opens</li> <li>Replace with known good motor</li> <li>Replace as required</li> <li>Replace with known good switch</li> </ul>
<ul style="list-style-type: none"> <li>Compressor Clutch does not work</li> </ul>	<ul style="list-style-type: none"> <li>No voltage at BK/Y wire of A/C Clutch Field Coil with A/C on</li> <li>Open in A/C Clutch Field Coil</li> <li>No continuity of BK wire of A/C Clutch Field Coil to ground</li> <li>Lack of R-12 refrigerant</li> </ul>	<ul style="list-style-type: none"> <li>Check Fuse 9 and wiring</li> <li>Replace with known good coil</li> <li>Check for open in BK wire</li> <li>Recharge as required</li> </ul>
<ul style="list-style-type: none"> <li>Hissing: No recirculating air</li> </ul>	<ul style="list-style-type: none"> <li>Vacuum line leak</li> <li>Defective Vacuum Motor</li> </ul>	<ul style="list-style-type: none"> <li>Repair as required</li> <li>Replace with known good motor</li> </ul>
<ul style="list-style-type: none"> <li>No cooling or not enough cooling</li> </ul>	<ul style="list-style-type: none"> <li>Compressor Drive Belt is loose</li> <li>Temperature Control Cable is out of adjustment</li> </ul>	<ul style="list-style-type: none"> <li>Tighten/Replace as required</li> <li>Adjust as required</li> </ul>

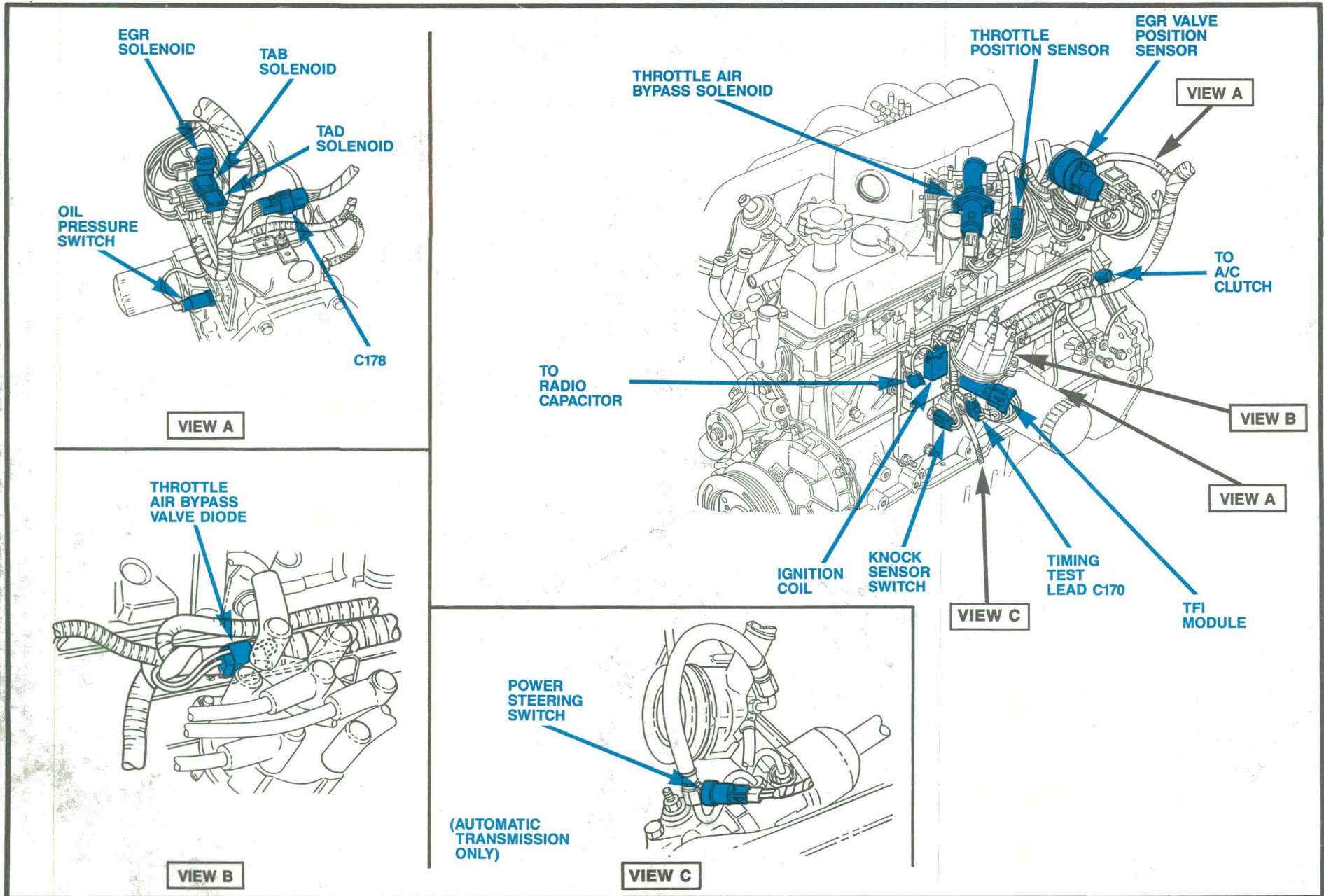

Figure 1 — LH Engine View 4.9L EFI

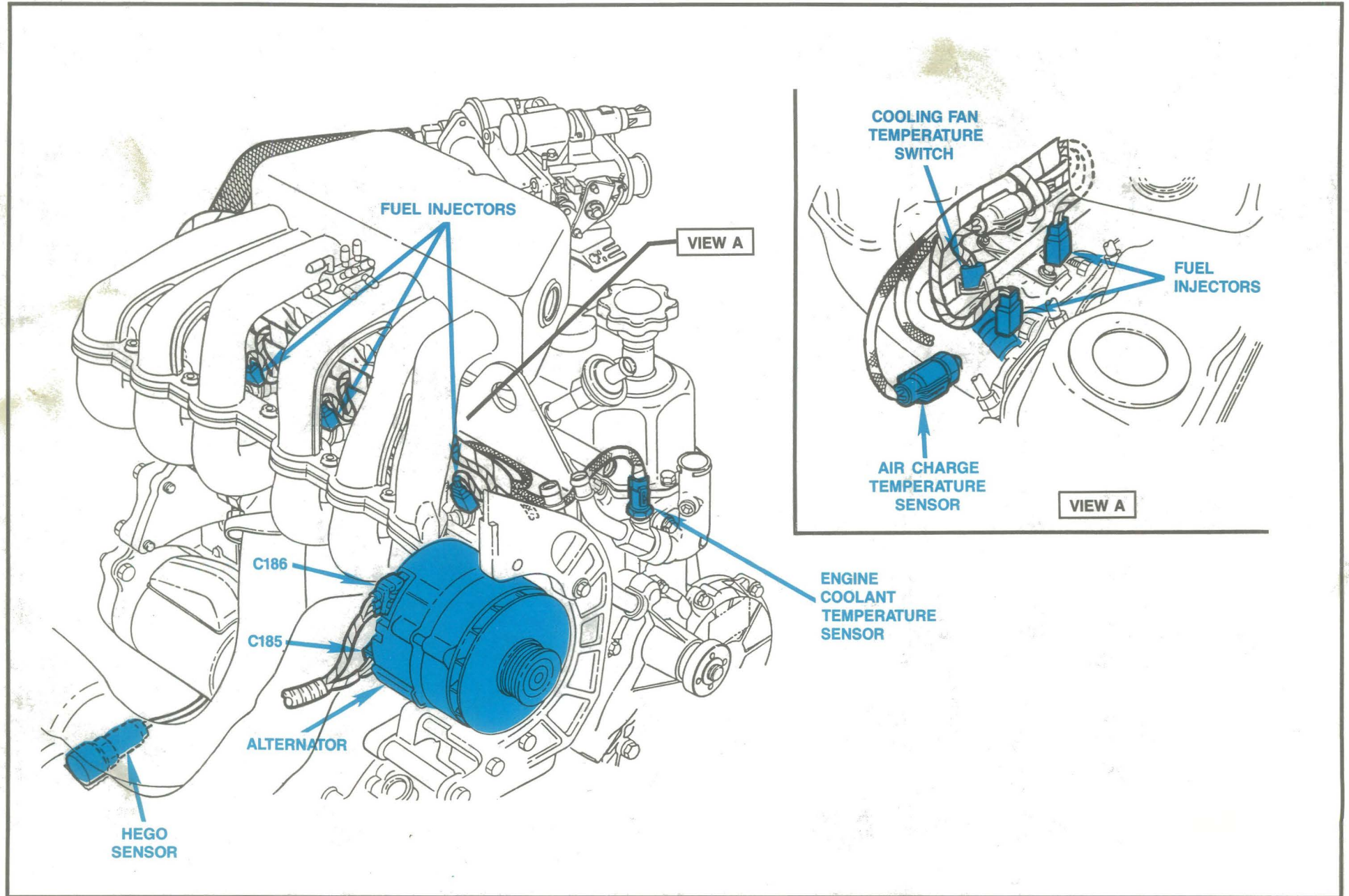

Figure 2 — RH Engine View — 4.9L EFI

## INTRODUCTION

Component testing procedures are provided to prove that a component is good or bad.

Testing information for each component includes a schematic, component terminal locations and step-by-step test procedures. Component terminals are identified:

- 1) by the circuit number of the wires that connect to that terminal;
- 2) by the wire insulation color;
- 3) by letters or numbers which may be marked on the component.

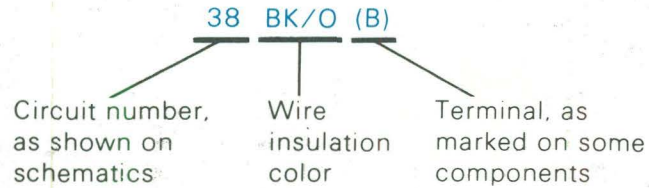

The component connector **MUST BE REMOVED** before testing. To test a single circuit within the component, select that circuit under the column **TO TEST**. If you wish to test the complete component, perform all tests.

Connect the tester to the terminals shown in the second column and operate the component as shown in the third column.

## MAIN LIGHT SWITCH

**SCHEMATIC**

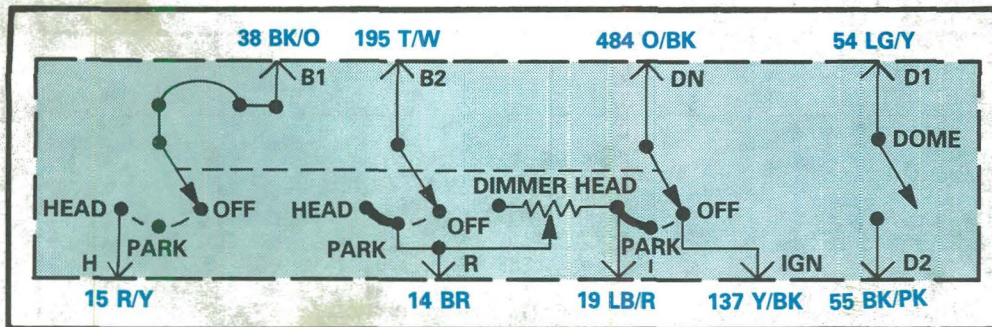

## COMPONENT TESTING PROCEDURE

TO TEST	Connect Self Powered Test Lamp or Ohmmeter to Terminals	Move Knob to These Positions	A Good Switch Will Indicate
<b>Headlamp Circuit</b>	38 BK/O (B) and 15 R/Y (H)	Off ..... Park ..... Head .....	Open Circuit Open Circuit Closed Circuit
<b>Park Lamp Circuit</b>	195 T/W (A) and 14 BR (R)	Off ..... Park ..... Head .....	Open Circuit Closed Circuit Closed Circuit
<b>Dome Light Circuit</b>	54 LG/Y (D1) and 55 BK/PK (D2)	Fully Counter-Clockwise (In Detent) ..... Clockwise (Any Amount Out of Detent) .....	Closed Circuit Open Circuit
<b>Panel Light Dimmer Circuit</b>	14 BR (R) and 19 LB/R (I)	Rotate Knob Clockwise .....	Ohmmeter Will Indicate Increasing Resistance
<b>Ignition On, Lamps Off Circuit</b>	137 Y/BK (IGN) and 484 O/BK (DN)	Off ..... Park ..... Head .....	Closed Circuit Open Circuit Open Circuit
<b>Cluster Dimmer Circuit</b>	19 LB/R (I) and 484 O/BK (DN)	Off ..... Park ..... Head .....	Open Circuit Closed Circuit Closed Circuit

**TERMINAL LOCATIONS ON SWITCH**

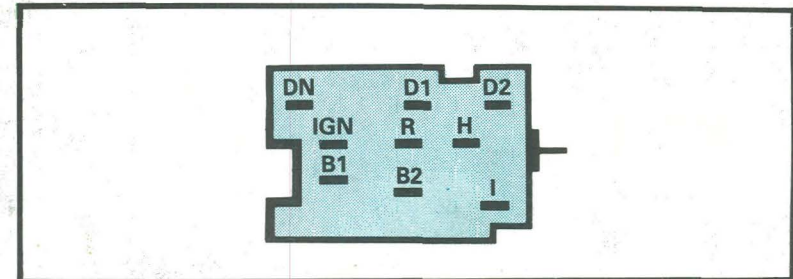

# 124 COMPONENT TESTING: IGNITION SWITCH (WITH SWITCH INSTALLED)

## COMPONENT TESTING PROCEDURE

TO TEST	Connect Self Powered Test Light or Ohmmeter to Terminals	Move Key to These Positions	A Good Switch Will Indicate
<b>Internal Switch Connections</b>  (perform these tests first)	37 Y (BATT) and 37 Y (BATT)	Accy, Lock, Off, Run, Start	Closed Circuit in all five positions
	687 GY/Y (A2) and 687 GY/Y (A2)	Accy, Lock, Off, Run, Start	Closed Circuit in all five positions
<b>Starter Relay Circuit</b>	37 Y (BATT) (either terminal) and 32 R/L B (ST)	Accy, Lock, Off, Run, Start	Closed Circuit in <b>Start</b> position only
<b>A/C, Heater Circuit, Turn/ Stop Lamps, Backup Lamps</b>	37 Y (BATT) (either terminal) and 687 GY/Y (A2) (either terminal)	Accy, Lock, Off, Run, Start	Closed Circuit in <b>Run</b> position only

## TERMINAL LOCATIONS

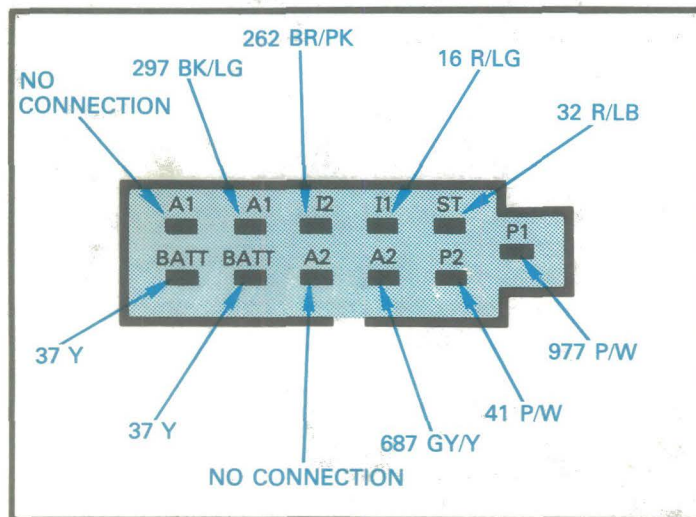

## COMPONENT TESTING PROCEDURE

TO TEST	Connect Self Powered Test Light or Ohmmeter to Terminals	Move Key to These Positions	A Good Switch Will Indicate
<b>Ignition Circuit</b>	37 Y (BATT) (either terminal) and 16 R/LG	Accy, Lock, Off, Run, Start	Closed Circuit in <b>Run</b> .
	37 Y (BATT) (either terminal) and 262 BR/PK (I2)	Accy, Lock, Off, Run, Start	Closed Circuit in <b>Start</b> position only
<b>"Accy" Circuit</b>	37 Y (BATT) (either terminal) and 297 BK/LG (A1)	Accy, Lock, Off, Run, Start	Closed Circuit in <b>Run</b> and <b>Accy</b> position only
<b>Bulb-Test Circuit</b>	41 BK/LB (P2) and Ignition Switch Case	Accy, Lock, Off, Run, Start	Closed Circuit in <b>Start</b> position only
	977 P/W (P1) and Ignition Switch Case	Accy, Lock, Off, Run, Start	Closed Circuit in <b>Start</b> position only

## SCHEMATIC

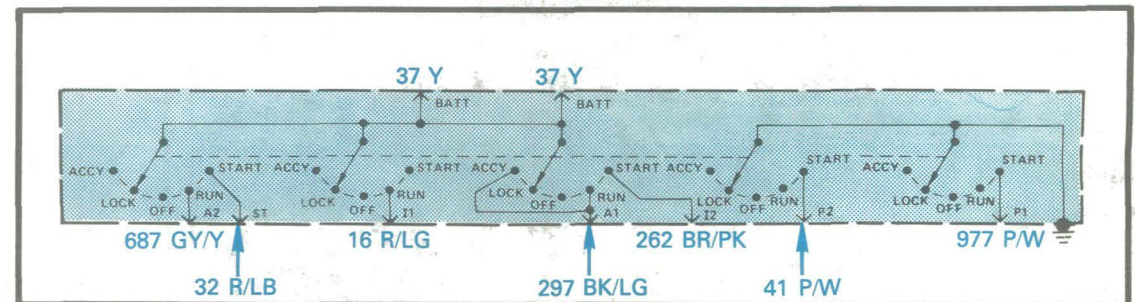

# COMPONENT TESTING: TURN/HAZARD SWITCH 125

## COMPONENT TESTING PROCEDURE

TO TEST	Connect Self Powered Test Light or Ohmmeter to Terminals	Move Switch to These Positions	A Good Switch Will Indicate
<b>Horn Switch Circuit</b>	460 Y/LB and 1 DB	Depress Horn Switch (If removed from truck, jumper brush contacts)	Closed Circuit
<b>LH Rear Turn Circuit</b>	44 LB and 9 LG/O	Turn Switch to Turn Left and Hazard Switch to Normal	Closed Circuit
<b>LH Front Turn Circuit</b>	44 LB and 3 LG/W	Turn Left	Closed Circuit
<b>RH Rear Turn Circuit</b>	44 LB and 5 O/LB	Turn Right	Closed Circuit
<b>RH Front Turn Circuit</b>	44 LB and 2 W/LB	Turn Right	Closed Circuit

## COMPONENT TESTING PROCEDURE

TO TEST	Connect Self-Powered Test Light or Ohmmeter to Terminals	Move Switch to These Positions	A Good Switch Will Indicate
<b>Hazard Switch Circuit</b>	385 W/R and 511 LG	Hazard	Closed Circuit
	385 W/R and 2 W/LB	Hazard	Closed Circuit
	385 W/R and 3 LG/W	Hazard	Closed Circuit
<b>Stop Lamp Feed-Through Circuit</b>	511 LG and 9 LG/O	Turn Switch to center (No Turn) position or Turn Right	Closed Circuit
	511 LG and 5 O/LB	Turn Switch to center (No Turn) position or Turn Left	Closed Circuit

## SCHEMATIC

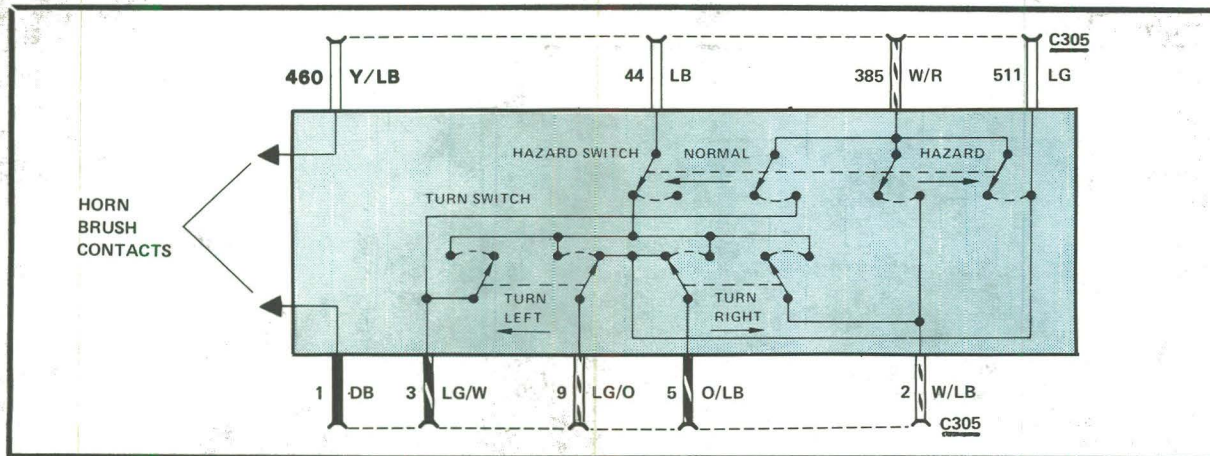

## TERMINAL LOCATIONS

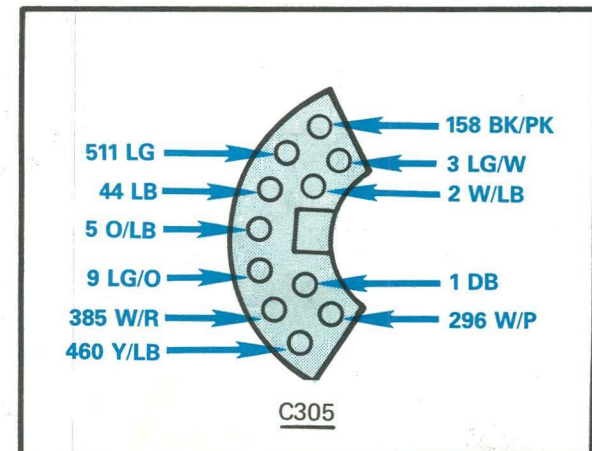

# 126 COMPONENT TESTING: WINDSHIELD WIPER/WASHER SWITCH

## TERMINAL LOCATIONS ON SWITCH

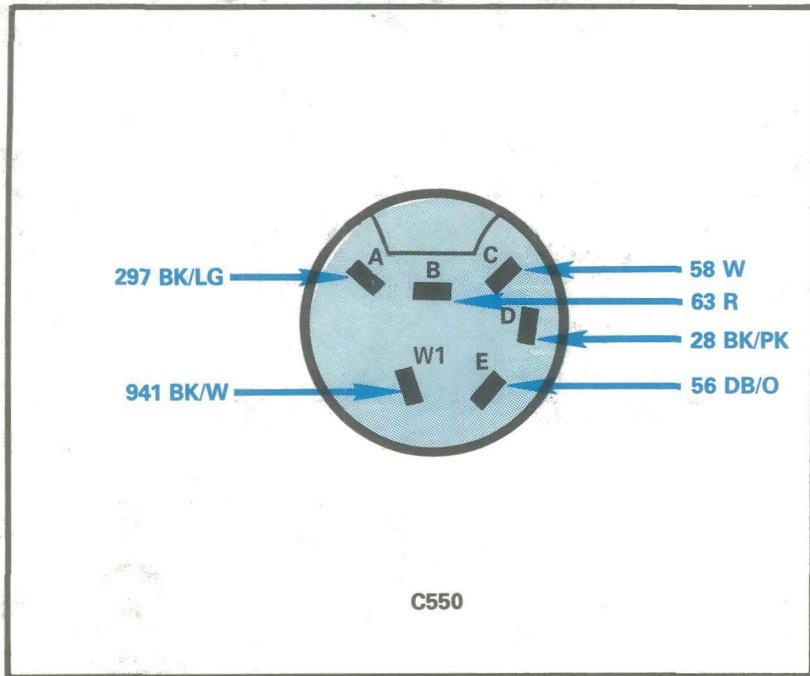

## COMPONENT TESTING PROCEDURE

TO TEST	Connect Self-Powered Test Light or Ohmmeter to Terminals	Move Switch to These Positions	A Good Switch Will Indicate
<b>Washer Switch Circuit</b>	941 BK/W (W1) and 63 R (B)	Push knob .....	Closed Circuit
		Release knob .....	Open Circuit
<b>Wiper Switch Circuit</b>	63 R (B) and 58 W (C)	Off .....	Open Circuit
		Lo .....	Closed Circuit
		Hi .....	Open Circuit
<b>Wiper Switch Circuit</b>	63 R (B) and 56 DB/O (E)	Off .....	Open Circuit
		Lo .....	Open Circuit
		Hi .....	Closed Circuit
<b>Wiper Switch Circuit</b>	58 W (C) and 28 BK/PK (D)	Off .....	Closed Circuit
		Lo .....	Open Circuit
		Hi .....	Open Circuit
<b>Circuit Breaker</b>	297 BK/LG (A) and 63 R (B)	All positions .....	Closed Circuit

## SCHEMATIC

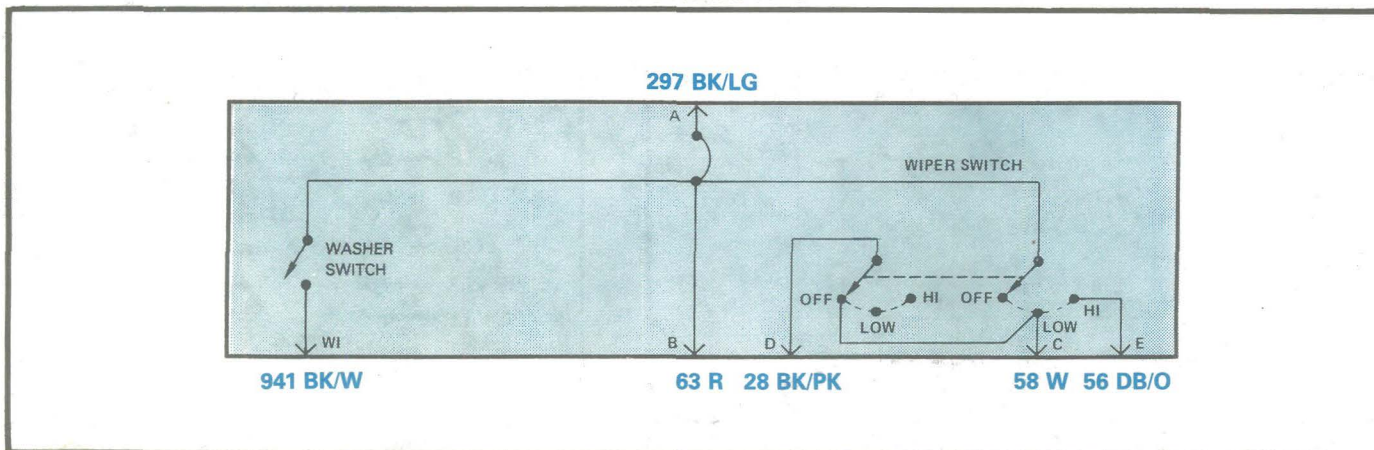

## TERMINAL LOCATIONS ON SWITCH

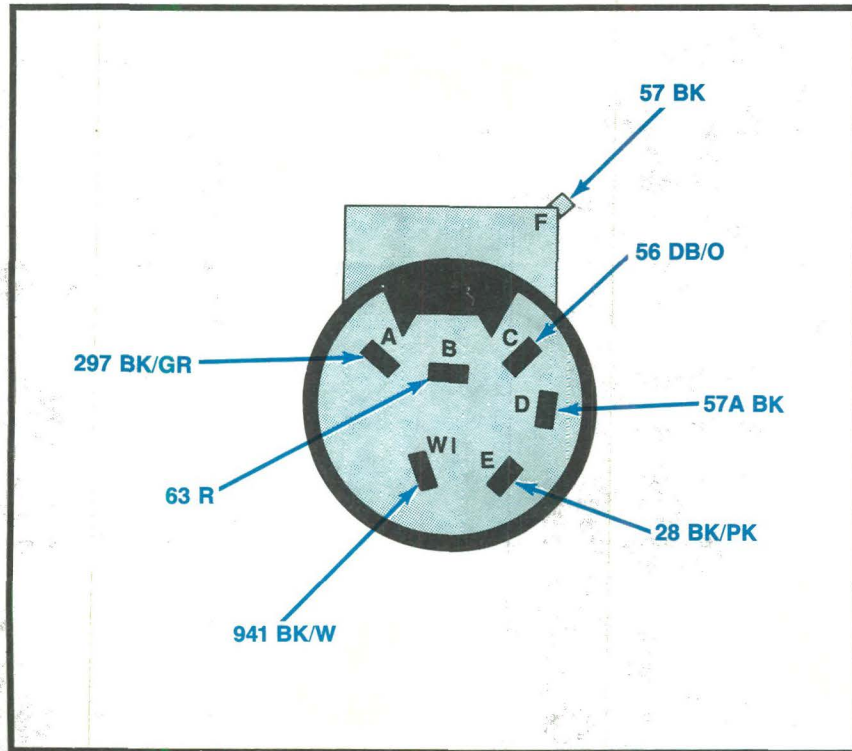

## COMPONENT TESTING PROCEDURE

TO TEST	Connect Self-Powered Test Light or Ohmmeter to Terminals	Move Switch to These Positions	A Good Switch Will Indicate
<b>Wiper Switch Circuit</b>	57 BK (F) and 57A BK (D)	Off ..... All other positions ....	Open Circuit Closed Circuit
	63 R (B) and 56 DB/O (C)	Hi ..... All other positions ....	Closed Circuit Open Circuit
	28 BK/PK (E) and 57 BK (F)	Off ..... Rotate Control ..... Clockwise Into Position (as Viewed from Connector Side). All other positions ....	Open Circuit Ohmmeter will indicate smoothly increasing resistance from 200-1000 ohms minimum to 5600-8400 ohms maximum Closed Circuit

## SCHEMATIC

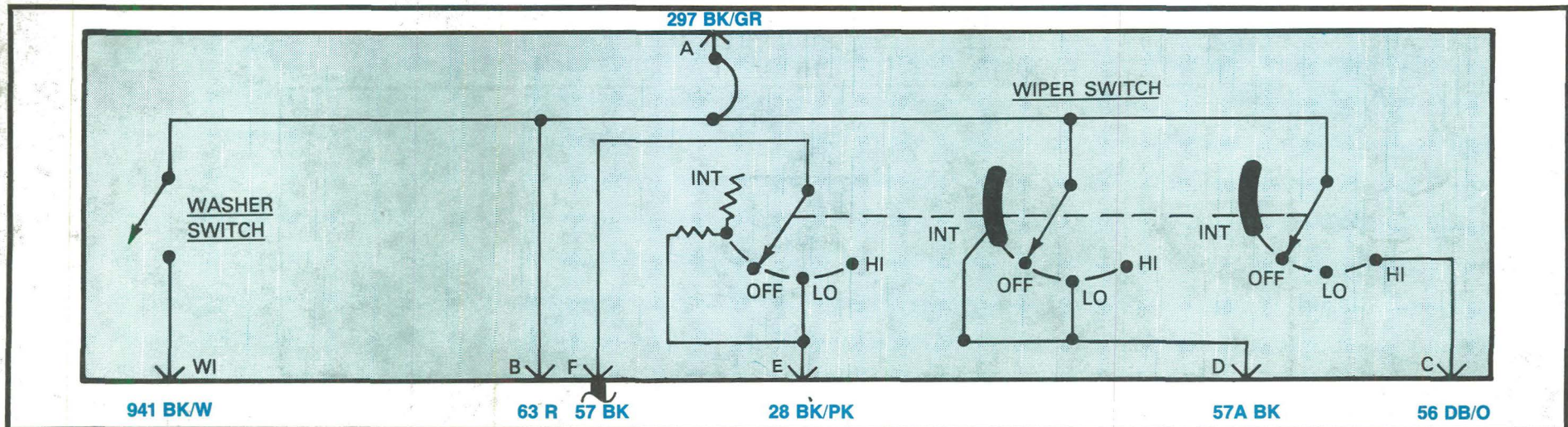

# 128 COMPONENT TESTING: A/C HEATER FUNCTION SELECTOR SWITCH

## TERMINAL LOCATIONS ON SWITCH

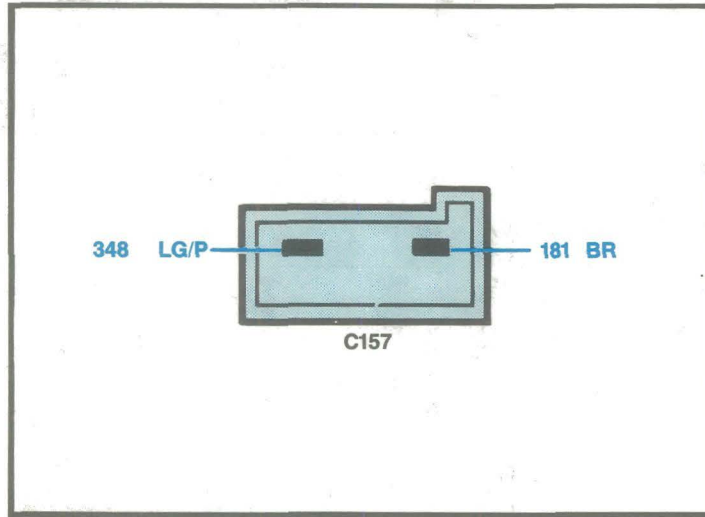

## COMPONENT TESTING PROCEDURE

TO TEST	Connect Self Powered Test Light or Ohmmeter to Terminals	Move Control to These Positions	A Good Switch Will Indicate
A/C Clutch Circuit	181 BR/O and 348 LG/P	Off On	Open Circuit Closed Circuit

## SCHEMATIC

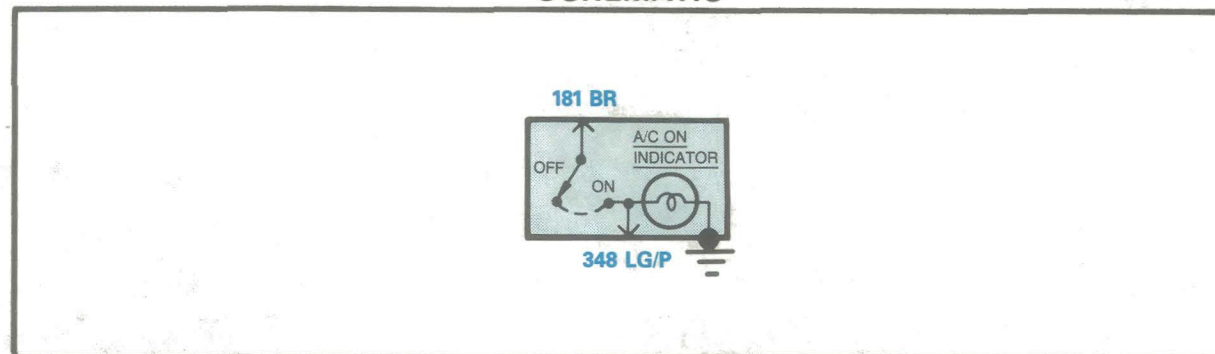

## TERMINAL LOCATIONS ON SWITCH

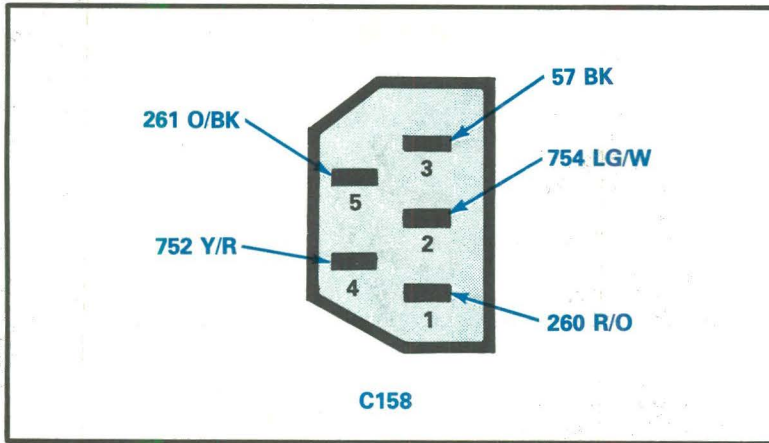

## SCHEMATIC

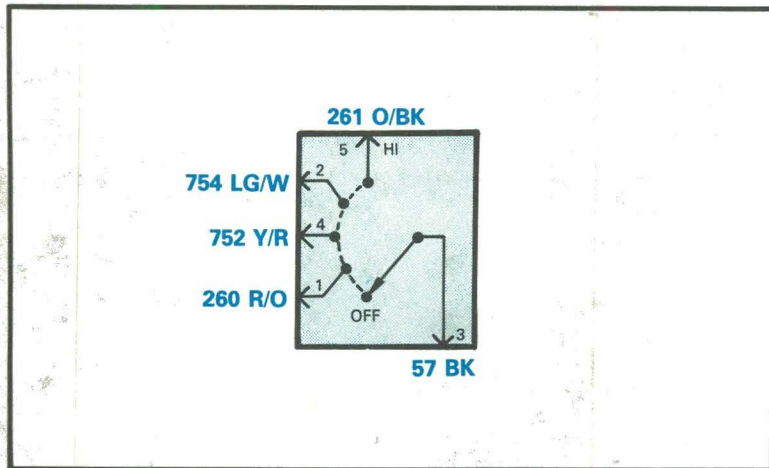

## COMPONENT TESTING PROCEDURE

TO TEST	Connect Self-Powered Test Light or Ohmmeter to Terminals	Move Switch to These Positions	A Good Switch Will Indicate
<b>Medium-Lo Speed</b>	57 BK (3) and 752 Y/R (4)	Lo ..... Medium-1 ..... Medium-2 ..... Hi .....	Open Circuit Closed Circuit Open Circuit Open Circuit
<b>Low Speed</b>	57 BK (3) and 260 R/O (1)	Lo ..... Medium-1 ..... Medium-2 ..... Hi .....	Closed Circuit Open Circuit Open Circuit Open Circuit
<b>Medium-High Speed (M2)</b>	57 BK (3) and 754 LG/W (2)	Lo ..... Medium-1 ..... Medium-2 ..... Hi .....	Open Circuit Open Circuit Closed Circuit Open Circuit
<b>Hi Speed</b>	57 BK (3) and 261 O/BK (5)	Lo ..... Medium-1 ..... Medium-2 ..... Hi .....	Open Circuit Open Circuit Open Circuit Closed Circuit
<b>Off</b>	57 BK (3) and all others	Lo ..... Medium-1 ..... Medium-2 ..... Hi .....	Open Circuit Open Circuit Open Circuit Open Circuit

# 130 LOCATION INDEX

## CONNECTOR LOCATION

		Page- Figure	Color	Terminals
C100	Through dash at LH side			53
C103	Near HEGO sensor			4
C104	At battery ground pigtail			4
C107	At license lamps	54-2	BR	1
C111	Behind I/P LH end (test)		BK	1
C117	At LH front side body marker lamp	55-8	BR	2
C122	RH side of rear cross support	54-3	BK	4
C123	LH side of frame at rear crossmember	102-5	BK	4
C126	LH side of rear crossmember	54-2		2
C129	At RH fender apron (diesel only)	33-1	GY	8
C151	Engine compartment		BK	2
C157	At A/C clutch switch		W	2
C158	At blower switch		GY	5
C168	Engine compartment test		GY	6
C170	Near ignition module	121-1	BK	2
C171	Engine compartment test			1
C174	At proportioning valve, LH frame rail		BK	4
C175	LH fender apron		BK	10
C176	LH fender apron		BK	8
C177	Engine compartment LH side		GY	12
C178	On rear of engine		BK	8
C182	Engine compartment LH		GY	6
C183	Engine compartment LH		BR	2
C185	At alternator	29-3		3
C186	At alternator	29-3		3
C187	At alternator regulator	34-3	W	4
C188	At alternator	34-3		2
C190	At clutch lockout switch	34-1	GY	2
C197	LH side of rear cross support		GY	5
C202	Lower hole of LH quarter panel	66-2,3,4	GY	3
C202A	Lower hole of LH quarter panel	66-2,3,4	GY	3
C203	Lower hole of LH quarter panel	66-2,3,4	GY	3
C208A	At instrument cluster			14
C208B	At instrument cluster			14
C233	Near alternator		GY	1
C240	At ignition key, seat belt warning buzzer			7
C244	Behind center of I/P		BK	8
C247	Engine compartment RH side			4
C248	Engine compartment near starter relay		GY/BK	4
C260	Near RH battery		BK	1
C270	At wiper motor			3
C271	At wiper motor			3
C275	Transmission crossmember			8
C276	At automatic transmission			5
C280	Engine compartment near starter relay			4
C284	At 4x4 switch		BK	2

## CONNECTOR LOCATION

		Page- Figure	Color	Terminals
C285	LH fender apron near power brake booster		GY	4
C285A	LH fender apron near power brake booster		BR	4
C285B	At speed sensor		BK	2
C289	RH cowl		BK	4
C290	RH cowl		GY	4
C292	At blower motor			2
C293	At blower resistor		W	4
C305	LH side of steering column		GY	11
C305A	LH side of steering column		GY	11
C305B	LH side of steering column		GY	11
C321	LH fender apron near ignition module		BK	3
C322	At distributor		BK	3
C323	At ignition module		BK	4
C333	Behind center of I/P at radio			8
C343	LH fender apron near ignition module		BK	8
C344	LH fender apron near ignition module		BK	8
C353	Rear LH side of frame at rear crossmember	54-4	Y	1
C354	At LH rear park & turn lamp	54-4	BK	2
C355	At RH rear park & turn lamp	54-4	BK	2
C356	At RH backup lamp	54-4	Y	1
C357	At LH backup lamp	54-4	Y	1
C358	Behind center of I/P		GY	2
C366	Behind I/P near fuse panel		GY	3
C366A	Behind I/P near fuse panel		GY	3
C366B	Behind I/P near fuse panel		GY	3
C370	Transmission crossmember		GY	4
C380	Engine compartment LH side			2
C386	Near RH battery			1
C406	LH cowl under I/P		GY	4
C420	Engine compartment LH side		BK	4
C425	RH cowl		BK	6
C426	RH cowl side		GY	2
C427	RH cowl side — electric shift module		GY	8
C428	RH cowl side — electric shift module		W	10
C429	RH cowl side — electric shift module		BR	5
C430	At electric shift transfer case		BK	10
C431	At electronic shift switch			6
C450	LH side rear support cross		BK	2
C522	Behind center of I/P at radio			8
C523	Lower LH cowl access hole		BR	2
C524	Lower RH cowl access hole	107-1	BR	2
C550	At windshield wiper/washer switch	95-1	BK	10
C650	At RH door lock motor		BK	2
C701	At main light switch		BK	8
C714	At speed control amplifier		GR	8

## CONNECTOR LOCATION

		Page- Figure	Color	Terminals
C717	At speed control amplifier		GY	6
C752	LH side of hood at engine compartment lamp		GY	1
C753	At speed control servo		BR	6
C755	At clutch switch		GR	2
C789	LH side of driver's seat on floor pan	72-1	GY	2
C850	Lower LH cowl access hole		GY	4
C906	At LH cowl access hole	54-7	BR	1
C913	At center of rear body markers	54-5	GY	2
C915	Engine compartment LH side		BK	2
C916	At LH side of rear crossmember	54-2	BK	2
C918	Near LH side of rear crossmember	54-2	GY	2
C950	At rear of LH rear fender	55-8	BR	2
C951	Near RH side of rear crossmember	54-6	BR	2
C952	At front of RH rear fender		BR	2
C953	At rear of RH rear fender	55-8	BR	2
C954	In forward part of cab roof	53-1	BK	2
C955	In forward part of cab roof	53-1	BK	2
C956	In forward part of cab roof	53-1	BK	2
C957	At front of cab roof	53-1	BK	2
C958	At front of cab roof	53-1	BK	2
C1002	At rear crossmember	60-1		3
C1101	Behind I/P LH end		BK	3
C1102	Behind I/P LH end		BR	6
C1105	LH side of frame at rear crossmember	55-9	BK	2
C1110	LH rear engine compartment	55-9	BR	6
C1111	LH rear of frame		BR	3
C1114	LH rear of frame			3
C1206	At rear crossmember	60-1		3
C1907	Behind LH rear lamp	102-4	BR	3
C1951	Behind LH rear crossmember	102-5 & 60-1	BR	1
C1952	Behind LH rear lamp	102-4	BR	1
C1953	LH cowl center access hole		GY	8
C1954	RH cowl center access hole		GR	8
C1955	LH cowl area			2
C1960	On fuse panel		N	1
C1962	At fuse panel		BL	1
C1963	LH frame rail		BK	2
C1964	Engine compartment LH side		BK	4

## SPLICE LOCATION

S110	Near fuel pump relay T/O
S140	Between S142 and S143
S142	Near T/O to no. 4 fuel injector
S143	Near T/O to no. 8 fuel injector
S150	In ignition coil lead
S151	Near license lamp T/O
S152	Near LH backup lamp T/O
S153	Near license lamp T/O
S154	Near front fuel gage sender T/O
S155	Near ERBP Valve T/O
S156	Near fuel line heater T/O
S157	Near LH headlamp T/O
S158	Near LH glow plugs T/O
S159	Near RH glow plugs T/O
S160	Near ignition coil T/O
S161	Near clutch interlock switch T/O
S162	Near heater control switch T/O
S163	Near heater control switch T/O
S165	In T/O to throttle air by pass solenoid
S167	In T/O to map sensor
S168	Near T/O to EEC diode
S170	Near battery
S172	Near T/O to EEC diode
S173	Near throttle position sensor T/O
S174	Near T/O to EEC power relay
S175	Near cooling fan relay T/O
S176	Near fuel tank selector valve T/O
S177	Near fuel tank selector valve T/O
S185	Near radio T/O
S190	Near backup lamp T/O
S200	Near clutch switch T/O
S208	Near main light switch T/O
S216	Near steering column connector T/O
S220	Near LH courtesy lamp T/O
S221	Near ignition switch T/O
S270	Between T/O's to EEC power relay
S271	Near T/O to C178 (LH side)
S272	Near main light switch T/O
S276	Near T/O to C178 (LH side)
S277	Near T/O to C178 (RH side)
S303	Near main light switch T/O
S305	In ignition coil lead
S350	Near main light switch T/O
S352	Near vehicle speed sensor T/O
S353	Near vehicle speed sensor T/O
S360	Near LH horn T/O

## SPLICE LOCATION

S101	Behind I/P near fuel/tank selector switch T/O
S108	Near tailgate power window switch T/O
S109	Near tailgate power window switch T/O

# 132 LOCATION INDEX

## SPLICE LOCATION

S404	Near clutch switch T/O
S410	Behind I/P in cooling fan harness
S450	Near license lamp T/O
S451	Near license lamp T/O
S452	Near rear turn/stop lamp T/O
S501	Near RH courtesy lamp T/O
S503	Near instrument cluster T/O
S504	Near instrument cluster T/O
S507	Near warning buzzer T/O
S508	Near warning buzzer T/O
S509	Near anti-lock brake module T/O
S510	Near anti-lock brake module T/O
S511	Near anti-lock brake module T/O
S512	Near fuel tank selector T/O
S513	Near fuse panel T/O
S515	Near driver's tailgate window switch T/O
S517	Near LH courtesy lamp T/O
S520	Near warning buzzer T/O
S522	Near trailer lamp relay T/O
S523	Behind I/P near marker lamp relay T/O
S530	Near clutch interlock switch T/O
S536	Near windshield wiper motor T/O
S538	Engine compartment near air charge sensor T/O
S541	Near diesel engine harness connector T/O
S543	Near brake sensor T/O
S545	Near LH headlamp T/O
S547	Engine compartment near HEGO ground T/O
S548	Engine compartment near #5 fuel injector T/O
S549	Engine compartment near #3 fuel injector T/O
S550	Near brake sensor T/O
S551	Engine compartment near #3 fuel injector T/O
S552	Engine compartment near throttle air bypass solenoid T/O
S554	Near speed sensor T/O
S555	Near ignition module T/O
S556	Near ignition module T/O
S560	Near fuel sedimenter bowl T/O
S562	Near A/C clutch T/O
S563	Near A/C clutch T/O
S565	Engine compartment near clutch interlock switch T/O
S567	Near T/O to A/C pressure cycling switch
S570	Near fuel tank sender T/O
S571	Near fuel tank sender T/O
S576	Near LH backup lamp T/O
S578	Near LH backup lamp T/O
S583	Near T/O to A/C clutch coil
S584	Near T/O to A/C clutch coil

Page-  
Figure

## SPLICE LOCATION

S590	In LH door near power window switch T/O
S591	In LH door near window control switch T/O
S603	Near blower motor switch T/O
S701	Near blower resistor T/O
S801	Near headlamp switch T/O
S805	Near cigar lighter T/O
S806	Near T/O to windshield wiper switch
S807	Near LH headlamp T/O
S808	Near RH park lamp T/O
S811	Near ignition switch T/O
S814	Near windshield wiper illumination lamp T/O
S815	Near G701 T/O
S850	Near main light switch T/O
S852	Near LH master window control switch T/O
S853	Near LH master window control T/O
S854	Near 4x4 indicator lamp T/O
S856	Near RH front door lock motor T/O
S857	Near RH front door lock motor T/O
S858	Near LH master window control T/O
S902	Near RH side marker lamp T/O
S903	Near fuel gage sender and pump T/O
S904	Near license lamp T/O
S1004	Near ignition switch T/O
S1103	Near RH courtesy lamp T/O
S1108	Near rear marker lamp T/O
S1109	Near LH front side marker lamp T/O
S1152	Near RH front side marker lamp T/O
S1205	Near rear license lamp T/O
S1207	Near dome lamp T/O
S1208	Near dome lamp T/O
S1902	Near tailgate power window switch T/O

## GROUND LOCATION

G111	RH frame near battery	24-2
G116	Near electronic engine control	
G117	Near ignition coil	
G119	Behind I/P near center	
G155	LH rear of engine	
G156	Center of dash panel	
G203	On RH side of engine	19-1,19-2,24-2

Page-  
Figure

**GROUND LOCATION**

Page-  
Figure

G208	Near throttle position solenoid	
G209	Center of dash panel	
G210	At electronic voltage regulator	
G211	Near starter motor relay	
G301	Near underhood lamp	
G502	Behind LH side of I/P	95-1
G701	Behind I/P at center	
G703	At brace under steering column	
G710	LH side of dash panel	
G711	LH rear of engine	
G751	At LH side of tailgate	
G752	In LH door	98-1
G801	LH inner fender behind headlamp	
G802	At RH inner fender behind headlamp	
G803	At fuel sedimenter bowl	
G804	At lower hole of LH quarter panel	65-1,66-2,3,4
G903	At LH side of crossmember	54-2
G909	At lower LH cowl access hole	54-7
G1006	Rear LH side of frame at rear crossmember	55-9
G1201	At front LH side of engine	24-1

# We Want To Hear From You!

Do you have any suggestions for improving this publication?

FOR EXAMPLE . . .

- Did you find any errors?

If yes; Manual \_\_\_\_\_ Page \_\_\_\_\_

\_\_\_\_\_  
\_\_\_\_\_  
\_\_\_\_\_

- Were any subjects not covered?

If yes; Please describe. \_\_\_\_\_

\_\_\_\_\_  
\_\_\_\_\_

- Were any sections confusing or hard to understand?

If yes; Manual \_\_\_\_\_ Page \_\_\_\_\_

Please comment: \_\_\_\_\_

\_\_\_\_\_  
\_\_\_\_\_

- Could you quickly find what you need? Yes \_\_\_\_\_ No \_\_\_\_\_

Suggestion: \_\_\_\_\_

\_\_\_\_\_  
\_\_\_\_\_

- Tell us who you are:

Name \_\_\_\_\_

Address \_\_\_\_\_

Position \_\_\_\_\_ Company \_\_\_\_\_

It would be most helpful if you could enclose a copy of each page, marked with your suggestions.

DO NOT STAPLE — USE TRANSPARENT TAPE

---

NO POSTAGE  
NECESSARY  
IF MAILED  
IN THE  
UNITED STATES

**BUSINESS REPLY MAIL**

FIRST CLASS PERMIT NO. 400 DEARBORN, MICH.

POSTAGE WILL BE PAID BY ADDRESSEE

Ford Parts and Service Division  
Advanced Service Engineering  
Fairlane Technical Center  
P.O. Box 1902  
Dearborn, Michigan 48121

---



**WE SUPPORT VOLUNTARY  
TECHNICIAN CERTIFICATION**



**Ford Parts and Service Division  
Training and Publications Department**



LITHO IN U.S.A.  
AUG. 1987

FPS-2129-88